



2014 - 2015







VISUAL COMUNICATION

X - Banner	4
L - Banner	6
Roll Up Banner	8
Roll Up Outdoor Banner	24
Roll Up LED	25
Scroll Banner	26
Mini Banner	27
Windows Banner	28
Cross Banner - Triple Banner	29
Bamboo Banner	30
Y - Banner	31
Outdoor Banner	32
Flying Banner	41
Beach Banner	44
Flying Banner - Accessories	45
Street Banner	46
Flags System	48
Barrier Banner - Exhibition Wall	52
Fashion Pop-Up	53
Velcro Pop-Up	54
Pop-Up	56
Accessories	65
TexFix	72
TexFix Light	78
TexFix - Accessories	82
Poster Display	83
Quick System	88
Promotion Counters	92
Carton Display	98
Carton Display Accessories	103
Cardboard Easel	108
Poster System	110
Bicycles Stand	115
Displays	116
Promo Shop	118
Promo Brand / Promo Cash	120
Promo Store	121
Turntables	122
Leds	124

X - BANNER

1

 Tragbares X-Banner aus Fiberglas, Aluminium und Kunststoff, mit großer visueller Wirkung, einfacher und schneller Auf- und Abbau. Inklusive Transporttasche.

 X-Banner, easy interchangeable graphic system that can provide a large visual impact. Portable and detachable. Made of different materials according model (fiberglass, aluminum and plastic parts). Lightweight and easy to assemble. Includes carry bag.

 X-Banner, support visuel. Portable et démontable. Fabriqué en différents types de matériaux selon le modèle (fibre de verre, aluminium et plastique). Léger et facile à monter. Sac de transport inclus.

 X-Banner provoca um grande impacto visual. É simples de usar e permite a mudança de imagem facilmente. Fabricado em diferentes materiais (fibra de vidro, alumínio e plástico). Saco de transporte incluído.

 X-Banner, display para colocación de gráfica. Portátil y desmontable. Fabricados en distintos materiales según modelo (fibra de vidrio, aluminio y partes plásticas). Ligero y fácil de montar. Incluye bolsa de transporte.

X-Banner Tudela

	QTY	N.W(kg)	G.W(kg)	C.B.M.	Size(mm)
Packing	10	13.5	17.5	0.07	300x200x1080
Uni.	1	1.35	1.75	0.05	160x30x1080

10.007 **600x1595mm**



	QTY	N.W(kg)	G.W(kg)	C.B.M.	Size(mm)
Packing	10	10.6	12.6	0.07	290x200x1210
Uni.	1	1.55	1.95	0.06	160x40x1210

10.111 **600x1800mm**



	QTY	N.W(kg)	G.W(kg)	C.B.M.	Size(mm)
Packing	10	11.75	13.75	0.07	290x200x1210
Uni.	1	1.65	2.05	0.06	170x40x1210

10.112 **800x1800mm**



X-Banner Valoria



	QTY	N.W(kg)	G.W(kg)	C.B.M.	Size(mm)
Packing	10	17	19	0.08	300x200x1410
Uni.	1	1.70	1.90	0.008	200x30x1360

10.006 **1200x1980mm**

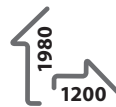

X - BANNER

Economic X-Banner



	QTY	N.W(kg)	G.W(kg)	C.B.M.	Size(mm)
Packing	65	19.5	22.7	0.17	400x400x1090
Uni.	1	0.30	0.35	0.009	140x60x1060

10.499

Lille - 600x1600mm



	QTY	N.W(kg)	G.W(kg)	C.B.M.	Size(mm)
Packing	60	21	24	0.17	400x400x1090
Uni.	1	0.35	0.40	0.009	140x60x1060

10.500

Lyon - 700x1800mm



	QTY	N.W(kg)	G.W(kg)	C.B.M.	Size(mm)
Packing	50	20	22.5	0.19	400x400x1200
Uni.	1	0.40	0.45	0.01	140x60x1230

10.501

Marseille - 800x2000mm

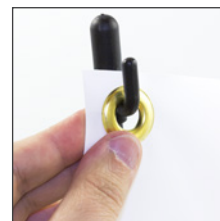

L - BANNER

1

 Tragbares L-Banner aus Fiberglas, Aluminium und Kunststoff, mit großer visueller Wirkung, einfacher und schneller Auf- und Abbau. Inklusive Transporttasche.

 L-Banner, easy interchangeable graphic system that can provide a large visual impact. Portable and detachable. Made of different materials according model (fiberglass, aluminum and plastic parts). Lightweight and easy to assemble. Includes carry bag.

 Support visuel, portable et démontable, fabriqué en fibre de verre, aluminium et plastique. Léger et facile à monter. Sac de transport inclus.

 L-Banner permite a mudança de imagem facilmente. É simples de usar e provoca um grande impacto visual. Fabricado em diferentes materiais (fibra de vidro, alumínio e plástico). Saco de transporte incluído.

 L-Banner, display para colocación de gráfica. Portátil y desmontable. Fabricados en distintos materiales según modelo (fibra de vidrio, aluminio y partes plásticas). Ligero y fácil de montar. Incluye bolsa de transporte.

L-Banner Mestanza



	QTY	N.W(kg)	G.W(kg)	C.B.M.	Size(mm)
Packing	25	10	11.25	0.073	300x230x1060
Uni.	1	0.40	0.45	0.004	140x30x1060

10.774

600x1600mm

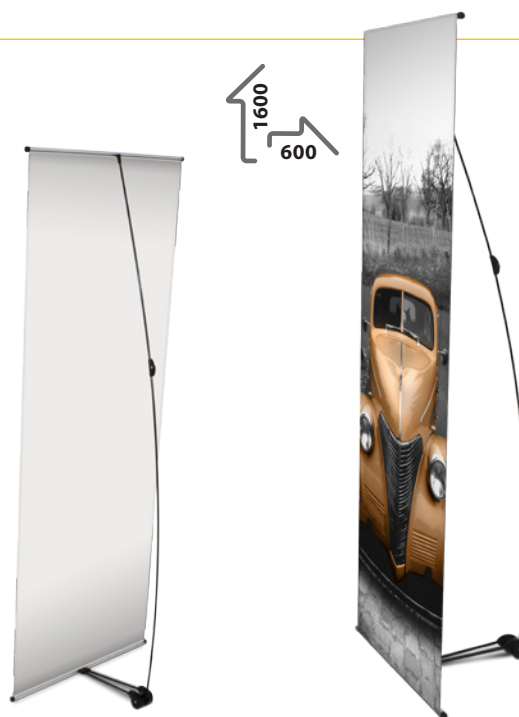

L-Banner Navas



	QTY	N.W(kg)	G.W(kg)	C.B.M.	Size(mm)
Packing	20	14	20	0.07	340x240x1000
Uni.	1	0.70	1	0.012	110x110x930

10.001

600x1840mm

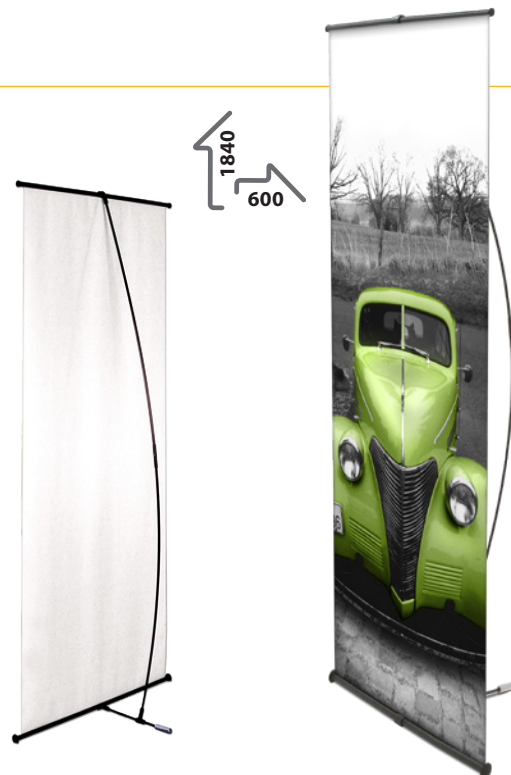

L - BANNER

L-Banner Sella

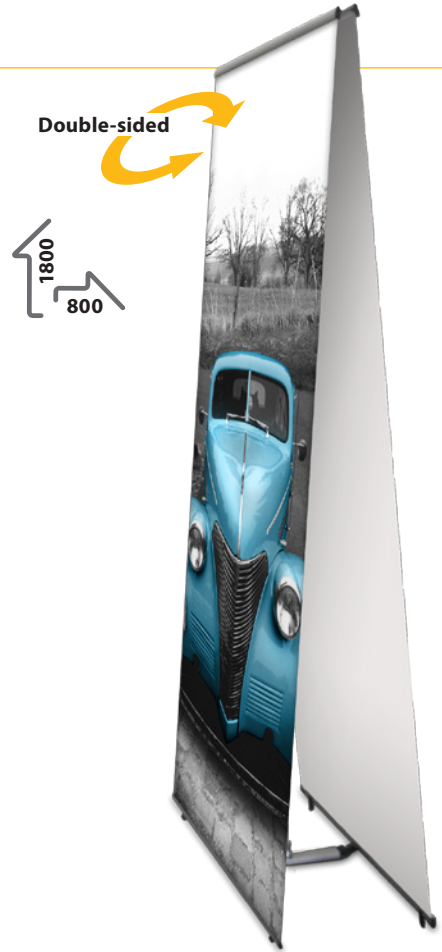
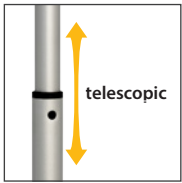

	QTY	N.W(kg)	G.W(kg)	C.B.M.	Size(mm)
Packing	10	16.5	18	0.048	230x200x1050
Uni.	1	1.65	1.80	0.009	100x100x920

10.437 800x1800mm



L-Banner Bonn

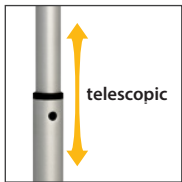
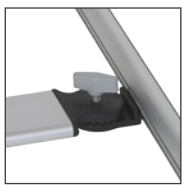

	QTY	N.W(kg)	G.W(kg)	C.B.M.	Size(mm)
Packing	10	12.5	14	0.048	230x200x1050
Uni.	1	1.25	1.40	0.0023	200x125x950

10.575 800x1800mm





ROLL UP BANNER

1

 Hochwertiges, mobiles Präsentationssystem mit stabilem Aluminiumgehäuse, mit einer gestanzten Fußstütze, einfache Handhabung. Inklusive Transporttasche.

 Retractable banner stand. No tools required, seconds to put up. It's portable and detachable. Produced in silver anodized aluminium and plastic parts. Includes carry bag.

 Support enrôleur pour visuel. Portable et démontable. Fabriqué en aluminium et plastique. Léger et facile à monter. Sac de transport inclus.

 Expositor retráctil de aluminio e plástico. Monta-se em segundos sem necessidade de utilizar ferramentas.

 Expositor enrollable para colocación de gráfica. Portátil y desmontable. Fabricados en aluminio y partes plásticas. Ligero y fácil de montar. Incluye bolsa de transporte.

Roll Up Abadia

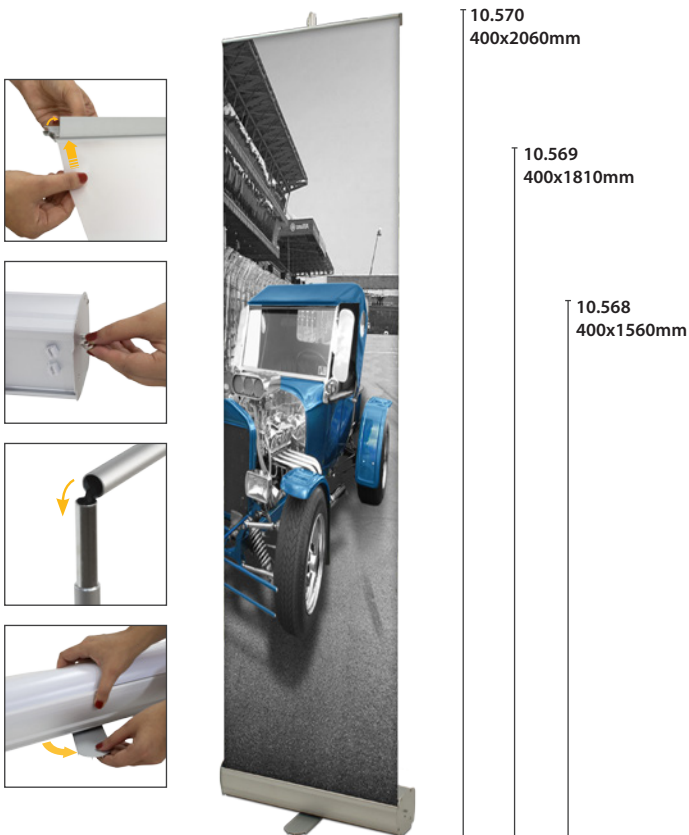

	QTY	N.W(kg)	G.W(kg)	C.B.M.	Size(mm)
Packing	12	18	19.50	0.054	400x300x450
Uni.	1	1.35	1.45	0.004	95x95x430
10.568	400x1560mm				

	QTY	N.W(kg)	G.W(kg)	C.B.M.	Size(mm)
Packing	12	19.20	20.70	0.054	400x300x450
Uni.	1	1.41	1.51	0.004	95x95x430
10.569	400x1810mm				

	QTY	N.W(kg)	G.W(kg)	C.B.M.	Size(mm)
Packing	12	20.40	21.90	0.054	400x300x450
Uni.	1	1.43	1.53	0.004	95x95x430
10.570	400x2060mm				

Roll Up Alzira

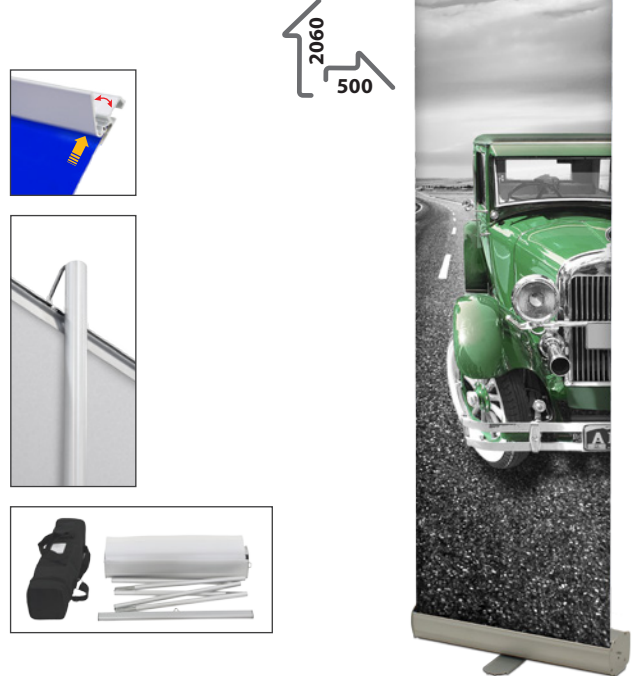

	QTY	N.W(kg)	G.W(kg)	C.B.M.	Size(mm)
Packing	6	9	10.2	0.05	340x240x580
Uni.	1	1.50	1.70	0.007	110x110x580

10.093	500x2060mm				
---------------	-------------------	--	--	--	---

Roll Up Albares

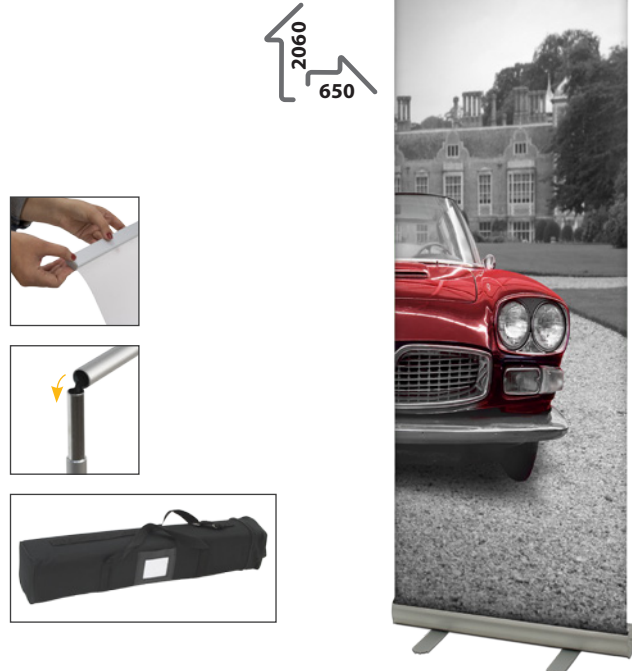

	QTY	N.W(kg)	G.W(kg)	C.B.M.	Size(mm)
Packing	6	9.60	10.6	0.06	340x240x730
Uni.	1	1.60	1.80	0.008	110x110x700

10.094	650x2060mm				
---------------	-------------------	--	--	--	---

ROLL UP BANNER

Economic Roll Up Alcalá



1

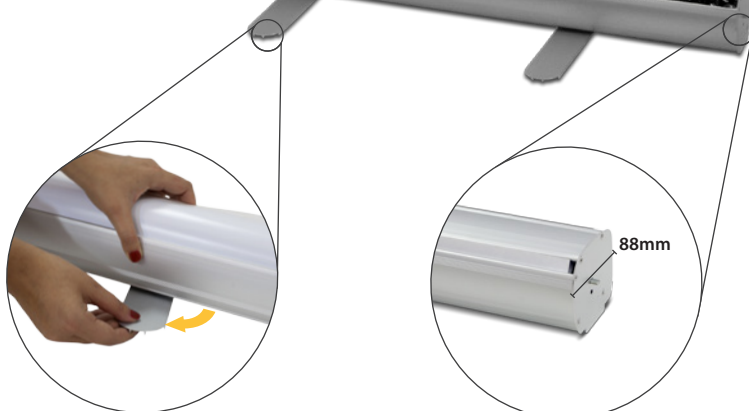
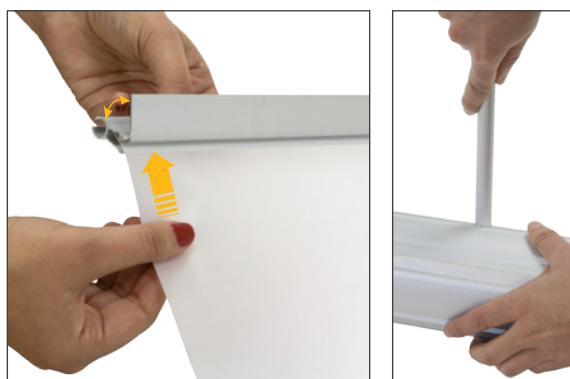

	QTY	N.W(kg)	G.W(kg)	C.B.M.	Size(mm)
Packing	10	20.93	21.41	0.08	475x200x900
Uni.	1	1.85	2.09	0.007	90x90x875

10.801

Alcalá - 850x2060mm



ROLL UP BANNER

1 Economic Roll Up Aviles - Ribadeo - Navia

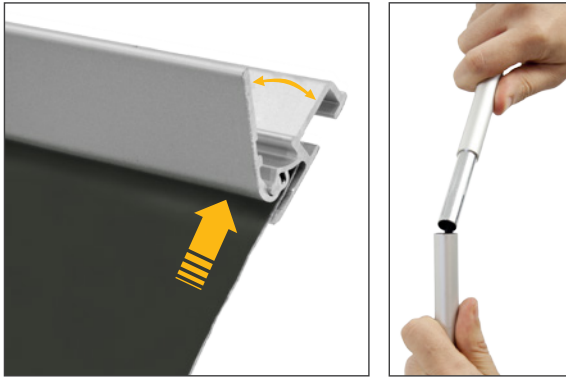

	QTY	N.W(kg)	G.W(kg)	C.B.M.	Size(mm)
Packing	10	20.8	22.1	0.063	480x200x1050
Uni.	1	2.08	2.21	0.01	90x90x1040

10.510 Aviles - 1000x2060mm



	QTY	N.W(kg)	G.W(kg)	C.B.M.	Size(mm)
Packing	6	15.30	16.50	0.078	300x200x1300
Uni.	1	2.55	2.75	0.012	95x95x1270

10.511 Ribadeo - 1250x2060mm



	QTY	N.W(kg)	G.W(kg)	C.B.M.	Size(mm)
Packing	6	17.70	18.60	0.093	300x200x1550
Uni.	1	2.95	3.10	0.013	100x95x1520

10.512 Navia - 1500x2060mm



ROLL UP BANNER

Standard Roll Up Alberca - Alaraz - Alhambra - Almorox



	QTY	N.W(kg)	G.W(kg)	C.B.M.	Size(mm)
Packing	6	12.60	14.40	0.07	320x230x910
Uni.	1	2.10	2.40	0.009	110x110x890

10.016 Alberca - 850x2060mm



	QTY	N.W(kg)	G.W(kg)	C.B.M.	Size(mm)
Packing	6	13.80	16.20	0.08	320x230x1070
Uni.	1	2.30	2.70	0.011	105x105x1040

10.365 Alaraz - 1000x2060mm



	QTY	N.W(kg)	G.W(kg)	C.B.M.	Size(mm)
Packing	6	18	21	0.12	360x250x1320
Uni.	1	3	3.50	0.012	100x100x1290

10.900 Alhambra - 1250x2060mm



	QTY	N.W(kg)	G.W(kg)	C.B.M.	Size(mm)
Packing	6	19.8	22.8	0.109	320x220x1560
Uni.	1	3.30	3.80	0.018	110x110x1540

10.899 Almorox - 1500x2060mm

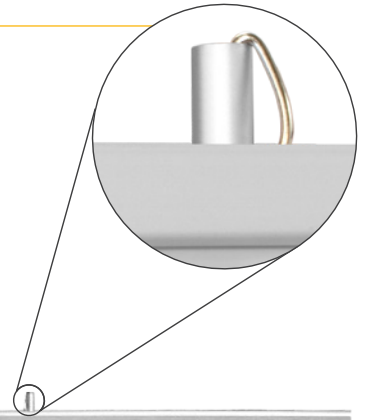

ROLL UP BANNER

1

Roll Up Almunia



	QTY	N.W(kg)	G.W(kg)	C.B.M.	Size(mm)
Packing	4	16	18.80	0.10	240x240x1810
Uni.	1	4	4.70	0.025	120x120x1785

10.095 **1750x2060mm**



Roll Up Almansa



	QTY	N.W(kg)	G.W(kg)	C.B.M.	Size(mm)
Packing	4	16.80	19.60	0.11	240x240x2060
Uni.	1	4.20	4.90	0.020	100x100x2030

10.896 **2000x2060mm**



ROLL UP BANNER

Roll Up Alpes

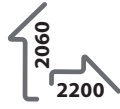

	QTY	N.W(kg)	G.W(kg)	C.B.M.	Size(mm)
Packing	4	19.2	23.2	0.132	240x240x2300
Uni.	1	4.8	5.8	0.032	120x120x2260

10.008

2200x2060mm



Roll Up Alaska



	QTY	N.W(kg)	G.W(kg)	C.B.M.	Size(mm)
Packing	1	8.10	9	0.048	140x140x2480

10.956

2400x2060mm



ROLL UP BANNER

1

Roll Up Altea



	QTY	N.W(kg)	G.W(kg)	C.B.M.	Size(mm)
Packing	10	22	24	0.093	490x210x910
Uni.	1	2.20	2.40	0.007	90x90x875

10.680  **850x2060mm** 

	QTY	N.W(kg)	G.W(kg)	C.B.M.	Size(mm)
Packing	10	25	26	0.109	490x210x1060
Uni.	1	2.50	2.60	0.011	105x105x1040

10.681  **1000x2060mm** 

Roll Up Banner Tablet Holder

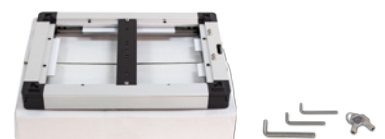
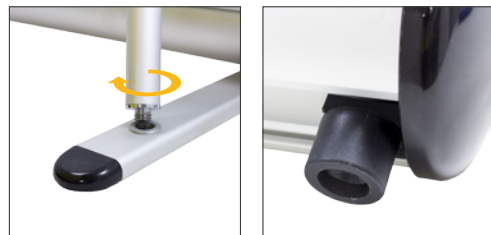

	QTY	N.W(kg)	G.W(kg)	C.B.M.	Size(mm)
Uni.	1	0.75	0.90	0.003	260x47x310
		3.60	4.10	0.013	130x110x930

10.035 Roll Up 850x2060mm Safety Holder for Tablet 185.8x241.3mm

	QTY	N.W(kg)	G.W(kg)	C.B.M.	Size(mm)
Uni.	1	0.75	0.90	0.003	260x47x310
		3.60	4.10	0.013	130x110x930

10.053 Roll Up 850x2060mm Safety Holder for Tablet 195.5x240mm

HIGHLY RESISTANT

1

Roll Up Algeciras



- Roll Up aus gehärtetem Stahl.
- Reinforced Steel.
- En acier renforcé.
- Aço reforçado.
- Reforzado en acero.



10.373



	QTY	N.W(kg)	G.W(kg)	C.B.M.	Size(mm)
Packing	6	12.9	15	0.0464	320x220x660
Uni.	1	2.15	2.5	0.0109	125x130x675

10.372 600x2060mm



	QTY	N.W(kg)	G.W(kg)	C.B.M.	Size(mm)
Packing	6	17.1	19.2	0.0640	320x220x910
Uni.	1	2.85	3.20	0.0145	125x130x895

10.373 850x2060mm



	QTY	N.W(kg)	G.W(kg)	C.B.M.	Size(mm)
Packing	6	18	21	0.0746	320x220x1065
Uni.	1	3	3.5	0.0173	125x130x1065

10.374 1000x2060mm



	QTY	N.W(kg)	G.W(kg)	C.B.M.	Size(mm)
Packing	4	15	17	0.1265	370x260x1315
Uni.	1	3.75	4.25	0.0213	125x130x1315

10.038 1250x2060mm



	QTY	N.W(kg)	G.W(kg)	C.B.M.	Size(mm)
Packing	4	18	20	0.1519	370x260x1580
Uni.	1	4.5	5	0.0256	125x130x1580

10.039 1500x2060mm





Roll Up Algeciras

HIGHLY RESISTANT

1

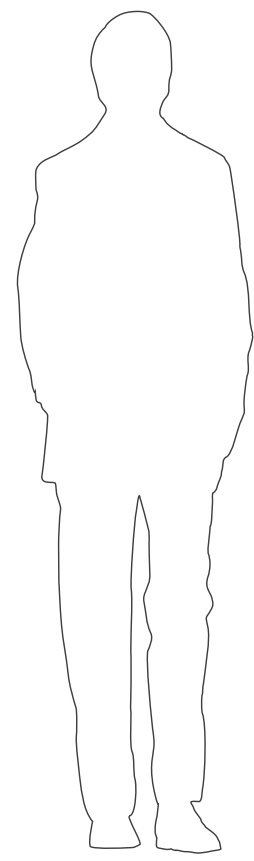

10.376



10.375

	QTY	N.W(kg)	G.W(kg)	C.B.M.	Size(mm)
Packing	4	22	24	0.125	260x260x1850
Uni.	1	5.5	6	0.0307	130x130x1820
10.375	1750x2060mm				

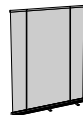

	QTY	N.W(kg)	G.W(kg)	C.B.M.	Size(mm)
Uni.	1	7.0	7.4	0.0353	125x125x2260
10.377	2200x2060mm				

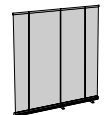

	QTY	N.W(kg)	G.W(kg)	C.B.M.	Size(mm)
Packing	4	26.4	28	0.0997	220x220x2060
Uni.	1	6.6	7	0.0343	130x130x2030
10.376	2000x2060mm				

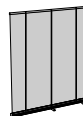

	QTY	N.W(kg)	G.W(kg)	C.B.M.	Size(mm)
Uni.	1	7.6	8	0.0384	125x125x2460
10.378	2400x2060mm				

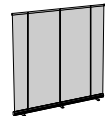

ROLL UP BANNER

1

Roll Up Lidine

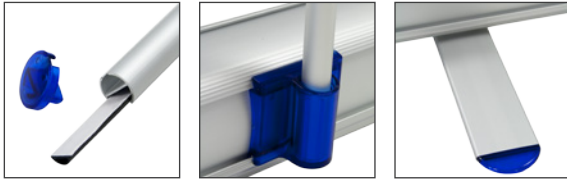
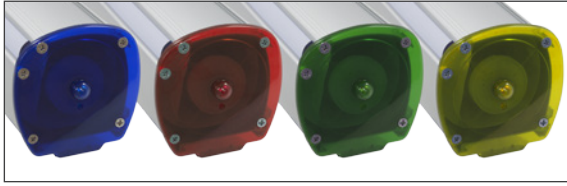

	QTY	N.W(kg)	G.W(kg)	C.B.M.	Size(mm)
Packing	6	15	17	0.09	380x260x920
Uni.	1	2.5	2.83	0.009	110x100x890

10.660

10.661

10.662

10.663

850x2060mm



Roll Up Dehesa

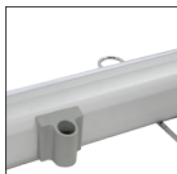
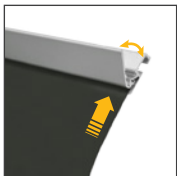
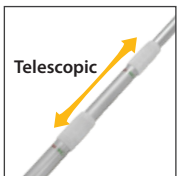

	QTY	N.W(kg)	G.W(kg)	C.B.M.	Size(mm)
Packing	6	19.20	23	0.09	360x260x910
Uni.	1	3.15	3.50	0.01	110x110x900

10.020

850x2260mm



Magnet Dispenser

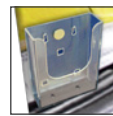

Broschürenhalter A6 mit doppeltem Magnet, Befestigung auf der Grafikoberfläche.

Acrylic leaflet dispenser, in A6 size with double magnet.

Support porte-brochures A6 avec double aimant.

Suporte em acrílico para porta-folhetos A6, com íman duplo para fixação.

Soporte portacatálogos A6 con doble imán.

	QTY	N.W(kg)	G.W(kg)	C.B.M.	Size(mm)
Uni.	5	0.85	0.95	0.004	165x130x215

10.860

A6

x5



ROLL UP BANNER

Roll Up Valdavia



	QTY	N.W(kg)	G.W(kg)	C.B.M.	Size(mm)
Packing	6	22.80	25.20	0.07	320x230x910
Uni.	1	3.80	4.20	0.01	110x105x890

10.017 **850x2060mm**



Roll Up Cervera

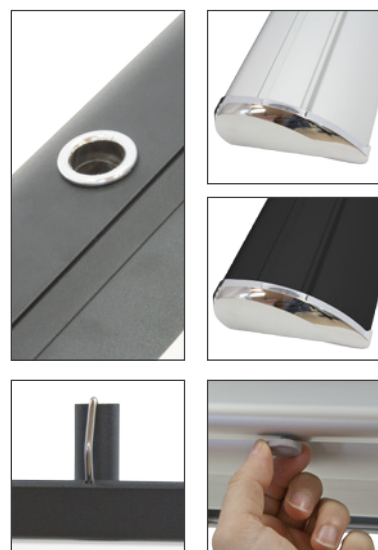

	QTY	N.W(kg)	G.W(kg)	C.B.M.	Size(mm)
Packing	4	18.2	23	0.16	530x300x980
Uni.	1	4.55	5.75	0.018	150x135x920

10.015 **850x2060mm**



10.955 **850x2060mm**



ROLL UP BANNER

1

Roll Up Ribas

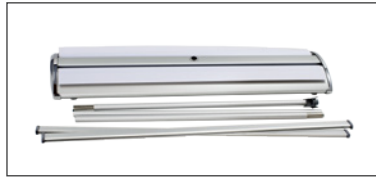

Double-sided



	QTY	N.W(kg)	G.W(kg)	C.B.M.	Size(mm)
Packing	4	22	26.6	0.16	530x300x980
Uni.	1	5.5	6.65	0.03	250x135x920

10.013 850x2060mm



Roll Up Fontiveros

Double-sided

	QTY	N.W(kg)	G.W(kg)	C.B.M.	Size(mm)
Packing	3	13	15	0.06	350x190x930
Uni.	1	4.40	4.70	0.021	180x130x900

10.014 850x2060mm



	QTY	N.W(kg)	G.W(kg)	C.B.M.	Size(mm)
Packing	3	15.60	16.80	0.07	350x190x1080
Uni.	1	5.20	5.60	0.024	180x130x1040

10.495 1000x2060mm



	QTY	N.W(kg)	G.W(kg)	C.B.M.	Size(mm)
Packing	3	20.40	21.60	0.09	350x190x1280
Uni.	1	6.80	7.20	0.025	115x175x1280

10.496 1250x2060mm



	QTY	N.W(kg)	G.W(kg)	C.B.M.	Size(mm)
Packing	3	24	25.20	0.11	350x190x1580
Uni.	1	8	8.40	0.033	180x120x1550

10.497 1500x2060mm



ROLL UP BANNER

Roll Up Asti

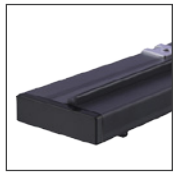
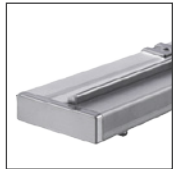

	QTY	N.W(kg)	G.W(kg)	C.B.M.	Size(mm)
Packing	4	19.6	21	0.126	500x260x970
Uni.	1	4.90	5.20	0.018	150x135x920

10.657		850x2060mm	
10.656		850x2060mm	

Roll Up Bremen

Mit Holzplatte und Broschürenhalter, die enthalten sind.

With wooden table and brochure holders included.

Avec tablette et porte-documents inclus.

Expositor retráctil com porta-folhetos e prateleira.

Con mesa de madera y portafolletos incluidos.



	QTY	N.W(kg)	G.W(kg)	C.B.M.	Size(mm)
Uni.	1	6.30	6.95	0.037	250x150x990

10.826		905x2060mm	
--------	--	------------	--

ROLL UP BANNER

1

Roll Up XXL Everest



	QTY	N.W(kg)	G.W(kg)	C.B.M.	Size(mm)
Packing	6	40.2	45	0.15	420x290x1260
Uni.	1	6.50	7.30	0.018	120x120x1260

10.861 1200x3060mm



Roll Up Valle



	QTY	N.W(kg)	G.W(kg)	C.B.M.	Size(mm)
Packing	1	13	14.80	0.061	180x160x2120

10.441 2000x3060mm



ROLL UP BANNER

Roll Up Max Elda Silver

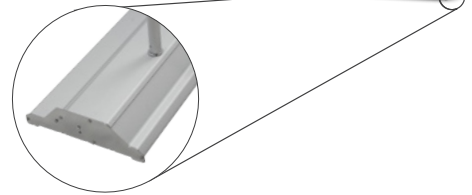
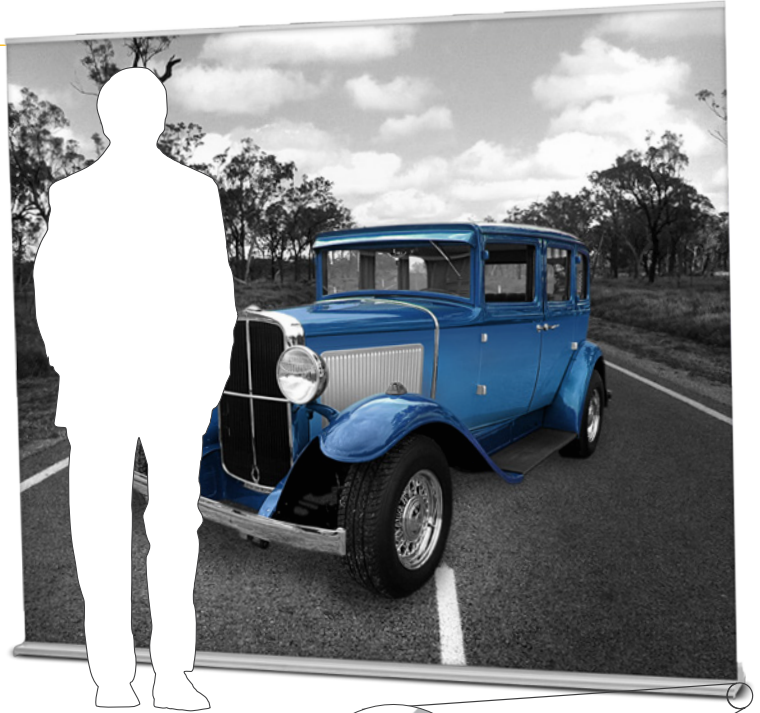

	QTY	N.W(kg)	G.W(kg)	C.B.M.	Size(mm)
Packing	2	21.2	26.6	0.189	320x230x2580
Uni.	1	10.6	13.30	0.071	320x90x2480

10.936 2400x2060mm



	QTY	N.W(kg)	G.W(kg)	C.B.M.	Size(mm)
Packing	2	22.0	30.10	0.253	320x230x3440
Uni.	1	11.00	15.05	0.096	320x90x3340

10.937 3200x2060mm



Roll Up Max Elda Black



	QTY	N.W(kg)	G.W(kg)	C.B.M.	Size(mm)
Packing	2	21.2	26.6	0.189	320x230x2580
Uni.	1	10.6	13.30	0.071	320x90x2480

10.667 2400x2060mm



	QTY	N.W(kg)	G.W(kg)	C.B.M.	Size(mm)
Packing	2	22.0	30.10	0.253	320x230x3440
Uni.	1	11.00	15.05	0.096	320x90x3340

10.668 3200x2060mm



ROLL UP OUTDOOR BANNER

1

Roll Up Exterior Ibiza

OUTDOOR

Double-sided

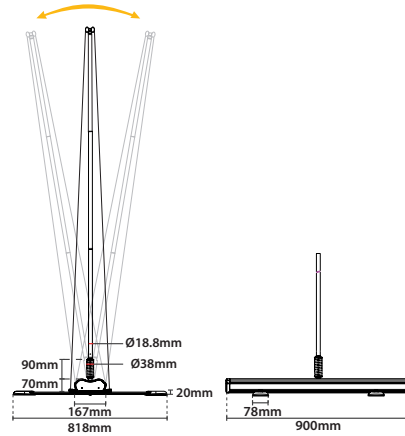
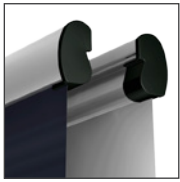

	QTY	N.W(kg)	G.W(kg)	C.B.M.	Size(mm)
Packing	1	7.6	8.8	0.03	300x110x930

10.447 850x2060mm



Roll Up Exterior Ascoli

OUTDOOR

Double-sided

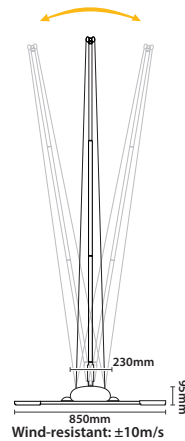
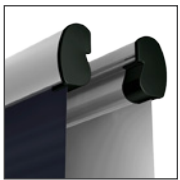

	QTY	N.W(kg)	G.W(kg)	C.B.M.	Size(mm)
Uni.	2	7.6	8.28	0.026	255x115x920
		5.8	6.4	0.021	170x140x920

10.655 850x2060mm





Roll Up, Bewegliches Banner & Zubehör mit LED System-Display. Mehrere Modi, um leicht durch USB programmieren.

Roll Up, Scroll Banner & accessories with LED System display. Several modes to program easily by USB.

Roll Up, Scroll Banner et accessoires avec système de LED. Différentes programmations par USB.

Roll Up, Scroll Banner e acessórios com sistema de LED. Diferentes programações por USB.

Roll Up, Scroll Banner y accesorios con sistemas de pantalla LED. Con múltiples modos programables mediante USB.

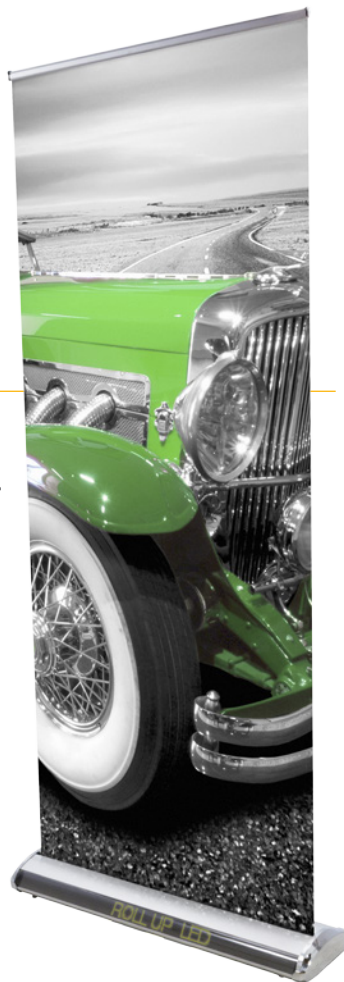

Roll Up LED



	QTY	N.W(kg)	G.W(kg)	C.B.M.	Size(mm)
Packing	1	5.55	6.0	0.031	245x135x940

13.477 **850x2060mm**



Scroll Banner LED



	QTY	N.W(kg)	G.W(kg)	C.B.M.	Size(mm)
Packing	1	6.0	6.55	0.031	245x135x940

13.479 **790x4430mm**



Support LED for Roll Up



	QTY	N.W(kg)	G.W(kg)	C.B.M.	Size(mm)
Packing	1	0.55	0.70	0.007	90x90x900

13.478 **850x50mm**



SCROLL BANNER

1

Scroll Banner Pineda

Bewegliches Banner mit automatischem Antrieb, stabiles Aluminiumgehäuse und Kunststoff. Höhe: 2000mm.

This scrolling banner is electrically powered to make a real eye catching exhibition. Aluminium and plastic parts. Height: 2000mm.

Banner électrique en aluminium et plastique permettant la rotation du visuel. Hauteur 2000mm.

Banner eléctrico de alumínio e plástico, para colocar no chão. Permite a colocação de uma imagem com efeito rotativo. Altura: 2000mm.

Banner eléctrico para suelo. Permite la colocación de una gráfica con efecto "scroll". Aluminio y partes de plástico. Altura: 2000mm.



	QTY	N.W(kg)	G.W(kg)	C.B.M.	Size(mm)
Packing	4	19.80	24.60	0.16	530x300x980
Uni.	1	4.95	6.15	0.034	280x130x925

10.022 **780x4105mm**



Scroll Banner Aranda

Bewegliches Banner mit automatischem Antrieb, inklusive Fernbedienung, Befestigung an Oberseite der Grafik, aus Aluminium und Kunststoff.

Single sided electric banner for ceiling suspension. Includes remote control. Made in aluminum and plastic parts.

Banner électrique d'une seule face à suspendre au plafond. Fabriqué en aluminium et plastique Télécommande incluse.

Banner eléctrico de alumínio e plástico de uma face para suspender do tecto. Inclui comando à distância.

Banner eléctrico para suspensión a techo a una cara. Incluye mando a distancia. Aluminio y partes de plástico.



	QTY	N.W(kg)	G.W(kg)	C.B.M.	Size(mm)
Packing	9	17.10	23.85	0.17	420x400x1000
Uni.	1	1.90	2.65	0.014	130x115x950

10.023 **800x3300mm**



Mobile Banner Marin

Schwenkfuß aus Kunststoff, für höhere Stabilität mit Wasser auffüllbar, für ein- oder doppelseitige Präsentationen nutzbar.

Mobile Banner with fillable plastic water base for better stability. Ideal for fixing solid board. The graphic can be used on one or both sides. Plastic, steel.

Banner mobile avec base en plastique à remplir d'eau, idéal pour la fixation de carton compact. Visuel double face.

Expositor móvel com base de plástico que se pode encher com água. Ideal para a fixação de cartão compacto. Possibilidade de utilização em simples ou dupla face.

Banner móvil con base de plástico rellenable de agua. Ideal para la fijación de cartón compacto. Uso a una o doble cara.



	QTY	N.W(kg)	G.W(kg)	C.B.M.	Size(mm)
Packing	1	2.10	2.65	0.03	310x85x1050

10.301 **600-900x1200mm**



MINI BANNER

 Schreibtisch-Banner Stand.

 Desk banner stand.

 Support Visuel à présenter sur table.

 Mini expositor retráctil.

 Sistema de colocación de gráficas de sobremesa.

Mini Roll Up Torrico



	QTY	N.W(kg)	G.W(kg)	C.B.M.	Size(mm)
Packing	24	9.60	12.20	0.041	370x300x370
Uni.	1	0.40	0.45	0.0014	90x45x345

10.786 **Torricon A3**



	QTY	N.W(kg)	G.W(kg)	C.B.M.	Size(mm)
Packing	24	8.4	9.60	0.03	300x280x370
Uni.	1	0.35	0.40	0.001	90x45x260

10.787 **Torricon A4**



Mini Flying Banner Krakow



	QTY	N.W(kg)	G.W(kg)	C.B.M.	Size(mm)
Uni.	1	0.30	0.35	0.0003	30x12x850

10.596 **Height: 550mm**

Mini X-Banner Tordesillas

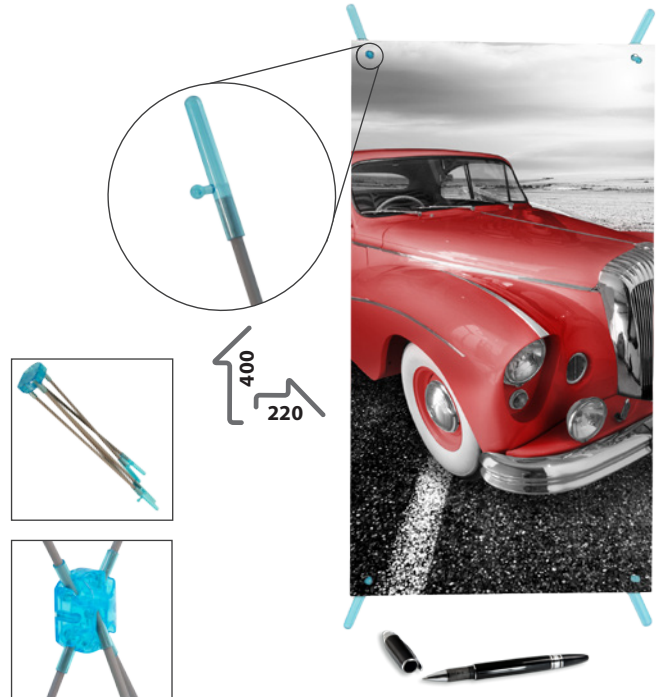

	QTY	N.W(kg)	G.W(kg)	C.B.M.	Size(mm)
Packing	200	10	14	0.07	380x140x500
Uni.	1	0.05	0.05	0.00045	45x35x285

10.009 **220x400mm**

WINDOWS BANNER

1

🇩🇪 Montagesystem mit Saugnäpfen.

🇬🇧 Fixing system for graphics using suction cups.

🇫🇷 Système de fixation de visuel avec ventouses.

🇵🇹 Sistema de colocação de imagens através de ventosas.

🇪🇸 Sistema de fijación de gráficas mediante ventosas.

Vargas

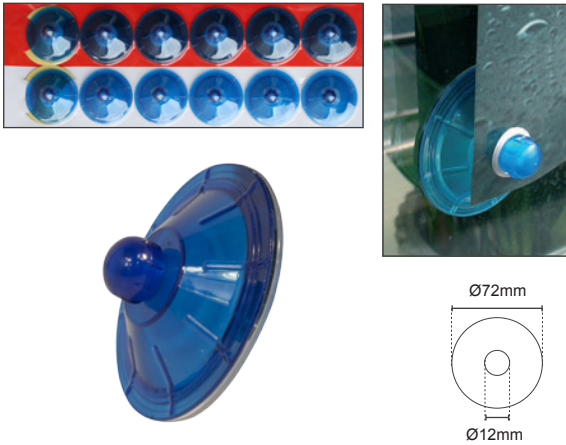

	QTY	N.W(kg)	G.W(kg)	C.B.M.	Size(mm)
Packing	12	0.4	0.45	0.04	580x170x40
10.798	x12 📦				

Cano

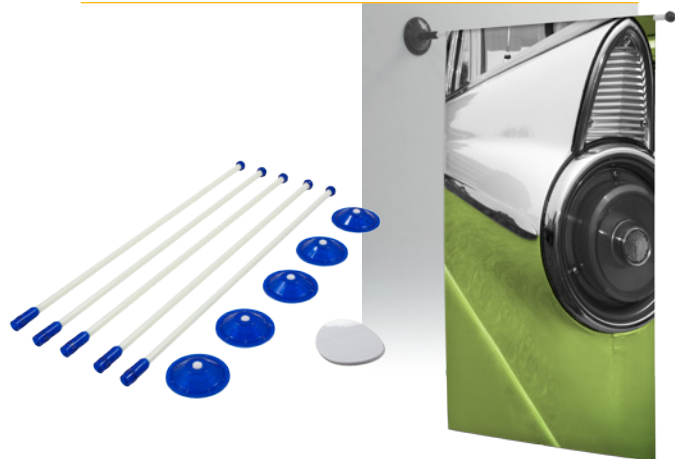

	QTY	N.W(kg)	G.W(kg)	C.B.M.	Size(mm)
Packing	5	0.5	0.55	0.002	170x20x640
10.797	500x900mm		x5 📦		

Gabin

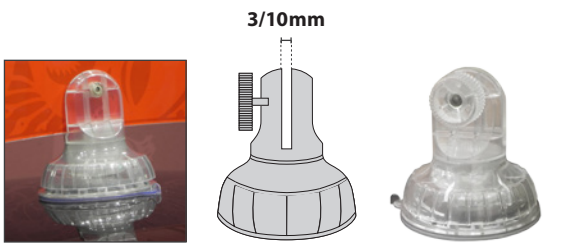

	QTY	N.W(kg)	G.W(kg)	C.B.M.	Size(mm)
Packing	1	0.25	0.3	0.001	125x125x125
10.595	Ø 120mm				

Viso

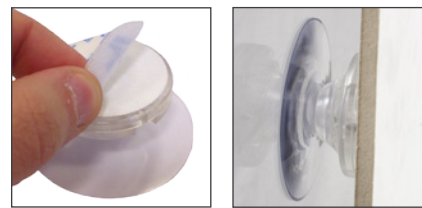
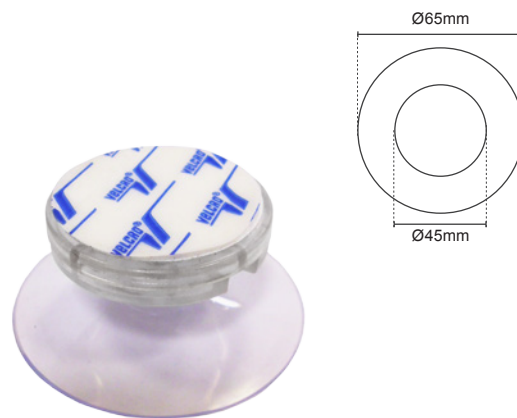

	QTY	N.W(kg)	G.W(kg)	C.B.M.	Size(mm)
Packing	4	0.09	0.15	0.0008	120x80x80
10.779	x4 📦				

CROSS BANNER - TRIPLE BANNER

Cross Banner Tormes

Doppelseitiges Präsentationssystem aus Aluminium und Kunststoff mit gekreuztem Fuß, Höhenverstellbar. Lieferung inkl. Transporttasche.

Versatile and cost effective cross banner stand. Double-sided. Adjustable height. Aluminium and plastic parts.

Support visuel double-face en aluminium et plastique avec pied en croix.

Expositor de dupla face com pé metálico em forma de cruz. Fabricado em alumínio e plástico.

Expositor con pie cruzado para gráfica promocional. Doble cara. Aluminio y partes de plástico.



Cross Banner Almeida

Doppelseitiges Präsentationssystem aus Aluminium und Kunststoff mit zwei Fußstützen, Höhenverstellbar. Lieferung inkl. Transporttasche.

Double-sided banner with two feet for better stability and includes adjustable height. Aluminium and plastic parts.

Support visuel double-face fabriqué en aluminium et plastique.

Expositor de dupla face com dois pés metálicos. Fabricado em alumínio e plástico.

Expositor con doble pie para gráfica promocional. Doble cara. Aluminio y partes de plástico.

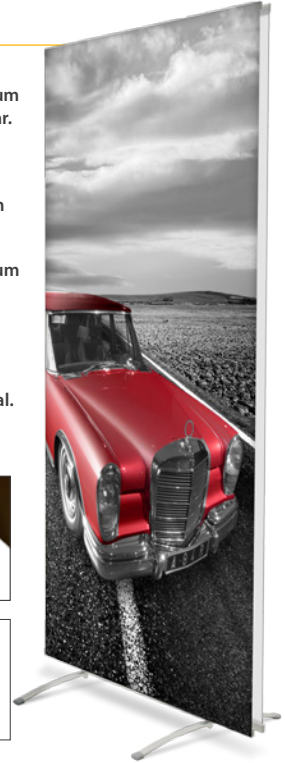

	QTY	N.W(kg)	G.W(kg)	C.B.M.	Size(mm)
Packing	10	14.50	18	0.08	340x240x980
Uni.	1	1.45	1.80	0.007	85x85x930

10.010 600x1700mm

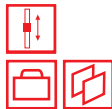

	QTY	N.W(kg)	G.W(kg)	C.B.M.	Size(mm)
Packing	10	26	29	0.11	340x240x1280
Uni.	1	2.60	2.90	0.014	120x100x1170

10.708 1000x2000mm

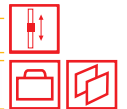

Triple Banner Galende



Dreiseitiges Präsentationssystem aus Aluminium und Kunststoff.

Triple banner allows the display of two or three graphics in a triangle shape. Aluminium, plastic parts.

Triple banner, allows the exposure of two or three graphics simultaneously in a triangle shape. Aluminium and plastic parts.

Expositor de alumínio e plástico que permite a colocação de duas ou três impressões.

Expositor para dos o tres gráficas promocionales. Aluminio y partes de plástico.

	QTY	N.W(kg)	G.W(kg)	C.B.M.	Size(mm)
Packing	5	14	16	0.017	400x150x1080
Uni.	1	2.65	3.05	0.02	160x160x650

10.012 915x2150mm



	QTY	N.W(kg)	G.W(kg)	C.B.M.	Size(mm)
Packing	5	25	26	0.11	310x210x1700
Uni.	1	3.35	4	0.02	120x120x1400

10.684 600x2985mm

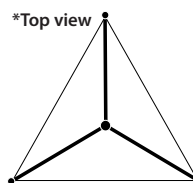

BAMBOO BANNER

1

- 🇩🇪 Leichtes X-Banner aus Bambus, einfacher und schneller Auf- und Abbau.
- 🇬🇧 Bamboo banner stand, allows an easy change of graphics. Stylish and functional design.
- 🇫🇷 Support visuel élégant et fonctionnel fabriqué en bambou.
- 🇧🇷 Expositores de bambou. Permitem a mudança das impressões facilmente.
- 🇪🇸 Expositores para gráfica fabricados en madera de Bambú. Elegante y funcional diseño.

Bamboo X-Banner



	QTY	N.W(kg)	G.W(kg)	C.B.M.	Size(mm)
Packing	40	20	22.50	0.13	450x270x1130
Uni.	1	0.50	0.55	0.004	105x40x980

10.449 **600x1600mm**



	QTY	N.W(kg)	G.W(kg)	C.B.M.	Size(mm)
Packing	40	34	36	0.15	280x450x1180
Uni.	1	0.85	0.90	0.005	105x40x1100

10.450 **800x1800mm**



Bamboo Roll Up



	QTY	N.W(kg)	G.W(kg)	C.B.M.	Size(mm)
Packing	4	12.6	15.2	0.091	350x290x900
Uni.	1	3.15	3.80	0.02	170x140x870

10.444 **800x2060mm**



Arbo





	QTY	N.W(kg)	G.W(kg)	C.B.M.	Size(mm)
Packing	6	13	15	0.41	600x450x1550
Uni.	1	2.50	3.30	0.003	490x40x1425

10.452 **400x1100mm**



Y - BANNER

 Y-Banner aus Aluminium und Kunststoff, Höhe justierbar.

 Y-Banner adjustable height. Fast assembly. Aluminium and plastic parts.

 Y-banner fabriqué en aluminium et plastique, réglable en hauteur.

 Y Banner ajustável em altura, de montagem rápida. Fabricado em alumínio e plástico.

 Y-Banner ajustable en altura. Aluminio y partes de plástico.

Y-Banner Almoguera



	QTY	N.W (kg)	G.W (kg)	C.B.M.	Size(mm)
Packing	6	15	16.80	0.13	380x260x1270
Uni.	1	2.30	2.75	0.018	120x120x1250

10.702 **1000x2350mm**



Y-Banner Mondejar



	QTY	N.W (kg)	G.W (kg)	C.B.M.	Size(mm)
Packing	6	18	20	0.13	380x260x1270
Uni.	1	2.80	3	0.016	120x120x1120

10.703 **1000x2350mm**

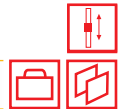

Y-Banner Pastrana



	QTY	N.W(kg)	G.W(kg)	C.B.M.	Size(mm)
Uni.	1	7	8	0.03	240x120x1250

10.704 **1000x2350mm x 3pcs**



OUTDOOR BANNER

1

Golf Banner Silves

 Flexibles Klappbanner, einfacher und schneller Auf- und Abbau, für In- und Outdoor Bereich, lieferbar in 3 Größen. Bestandteile:

- Transporttasche.
- Metallhaken zur Verankerung.
- Verbindungsstücke für Fiberglasstangen.
- Fiberglasstangen.
- Schwarzer Stoff für den Rand, Breite 60mm.

 Foldable banner, easy installation, ideal for indoor and outdoor events. The system allows a rapid single person set-up. Available in 3 sizes. Components:

- Carry bag.
- Hooks.
- Fiber glass pole connectors.
- Fiber glass pole.
- Black fabric of 60mm width.

 Banner pliable, montage facile, idéal pour des événements d'intérieur ou d'extérieur. Disponible en trois dimensions. Inclus:

- Sac de transport.
- Crochets métalliques de fixation.
- Bague en fibre.
- Connexion pour les baguettes en fibre.
- Textile noir de 60mm de large.

 Expositor em tecido para exterior. Este sistema permite que uma só pessoa monte o expositor de forma fácil e rápida. Fabricado em fibra de vidro e plástico. Conteúdo:

- Bolsa de transporte.
- Ganchos metálicos para fixar.
- Uniãoess para as barras de fibra.
- Barras de fibra.
- Tela preta com 60mm para o rebordo.

 Banner plegable de fácil montaje ideal para eventos tanto de interior como de exterior. Disponible en 3 tamaños. Componentes:

- Bolsa de transporte.
- Ganchos metálicos para clavar (piquetas).
- Conectores para los palos de fibra.
- Palos de fibra.
- Tela negra de 60mm de ancho de borde.

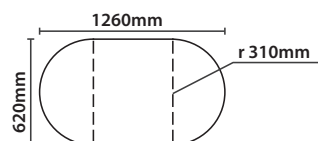
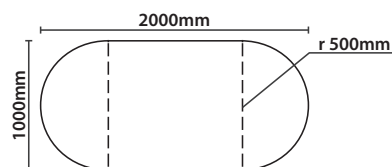
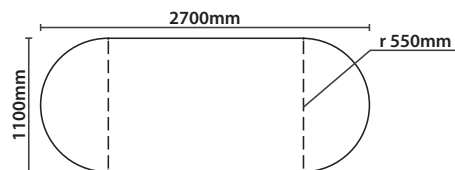

	QTY	N.W(kg)	G.W(kg)	C.B.M.	Size(mm)
Packing	5	12.50	13	0.26	1200x180x1200
Uni.	1	2.50	2.60	0.05	1140x30x1140
10.426	1100x2700mm				

	QTY	N.W(kg)	G.W(kg)	C.B.M.	Size(mm)
Packing	5	8.50	30	0.16	960x180x960
Uni.	1	0.90	1	0.045	950x50x950
10.427	1000x2000mm				

	QTY	N.W(kg)	G.W(kg)	C.B.M.	Size(mm)
Packing	5	7	7.25	0.08	660x180x660
Uni.	1	1.40	1.45	0.012	640x30x640
10.428	620x1260mm				

OUTDOOR BANNER

Almazan

X-Banner aus Fiberglasstangen und lackiertem Aluminium, Kunststofffuß mit Wasser auffüllbar.

X-Banner with large plastic base that can be filled with water. Fiberglass, aluminium.

Support visuel en fibre de verre et aluminium avec base à remplir d'eau.

Suporte tipo "X", com base de plástico que se pode encher com água, fabricado em fibra de vidro e alumínio lacado.

Soporte tipo "X", con base de plástico rellenable de agua, y fabricado en fibra de vidrio y aluminio lacado.



	QTY	N.W(kg)	G.W(kg)	C.B.M.	Size(mm)
Pole	1	0.55	0.6	0.004	80x65x750
Base	1	0.95	1	0.015	250x170x350

10.028 **600x1800mm**

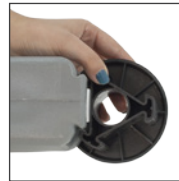

6 kg Water

Almenar

Banner aus Fiberglasstangen und lackiertem Aluminium, Kunststofffuß kann für mehr Stabilität mit Wasser aufgefüllt werden, Höhe verstellbar.

Y-Banner for promotional graphics, with plastic base that can be filled with water. Adjustable height. Fiberglass, aluminium.

Support visuel, en forme de Y, ajustable en hauteur, fabriqué en fibre de verre et aluminium. Base en plastique à remplir d'eau.

Y-Banner ajustável em altura para exterior com base que se pode encher com água. Fabricado em alumínio e fibra de vidro.

Soporte para gráfica promocional tipo "Y", regulable en altura. Con base de plástico rellenable de agua, varillas de fibra de vidrio y aluminio lacado.



	QTY	N.W(kg)	G.W(kg)	C.B.M.	Size(mm)
Packing	6	13	16.20	0.1	400x320x850
Uni.	1	1.8	2.2	0.02	240x100x840

10.029 **800x1900mm**

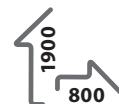



6 kg Water

OUTDOOR BANNER

1

Outdoor Roll Up Haro

 Doppelseitiger Outdoor-Banner mit Kunststofffuß, welcher mit Wasser befüllt werden kann. Aluminium, Kunststoffteile.

 Double-sided Outdoor Banner. Made of aluminum and refillable plastic base.

 Support visuel en aluminium, double face, avec base en plastique à remplir d'eau.

 Expositor retráctil de dupla face com base de plástico que se pode encher com água. Fabricado em alumínio e plástico. Ideal para exterior.

 Banner de exterior doble cara. Realizado en aluminio y base de plástico rellenable.



	QTY	N.W(kg)	G.W(kg)	C.B.M.	Size(mm)
Uni.	1	17.7	19.6	0.17	620x230x1160

10.954

800x2000mm



Medinaceli

 Banner mit Aluminiumstäben und Kunststofffuß, mit Wasser auffüllbar.

 Banner with plastic base that can be filled with water. Steel, plastic parts.

 Support visuel en acier avec base en plastique à remplir d'eau.

 Banner em aço e plástico para exterior com base que se pode encher com água.

 Banner con base de plástico rellenable de agua, y varillas de aluminio.

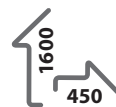

	QTY	N.W(kg)	G.W(kg)	C.B.M.	Size(mm)
Packing	2	7	8.6	0.11	540x190x1050
Uni.	1	2.85	3.50	0.05	500x100x1030

10.026

450x1600mm



OUTDOOR BANNER

Cepeda

Outdoor Banner aus Aluminium und Kunststofffuß, mit Wasser auffüllbar, höhenverstellbar.

Exterior banner with plastic base that can be filled with water. Adjustable in height. Aluminium, plastic parts.

Support visuel en aluminium, ajustable en hauteur, idéal pour l'extérieur. Base en plastique à remplir d'eau.

Expositor para exterior ajustável em altura com base que se pode encher com água. Fabricado em aço e plástico.

Banner de exterior para gráfica promocional. Realizado en aluminio y base de plástico rellenable. Ajustable en altura.



20 kg Water

	QTY	N.W(kg)	G.W(kg)	C.B.M.	Size(mm)
Pole	1	1.5	1.7	0.01	100x90x1160
Base	1	2	2.25	0.05	460x240x470

10.800

800x1800-2300mm



Kiel

Outdoor Banner aus Aluminium und Kunststofffuß, mit Wasser auffüllbar, Höhe verstellbar, ein- oder doppelseitig. Empfohlene Grafikgröße: 900x1750mm.

Single or double sided water filled Banner. Telescopic aluminium support pole and adjustable central hub allows the adjustment of height. Graphic area recommended: 900x1750mm. Aluminium, plastic parts.

Support visuel en aluminium, ajustable en hauteur, idéal pour l'extérieur. Base en plastique à remplir d'eau. Disponible en simple et double face. Format du visuel recommandé: 900x1750mm.

Expositor de simples ou dupla face com base que se pode encher com água. Possui um mastro central ajustável em altura. Área de impressão recomendada: 900x1750 mm.

Banner de exterior para gráfica promocional. Realizado en aluminio y base de plástico rellenable. Ajustable en altura. Disponible en 1 o 2 caras. Área gráfica recomendada: 900x1750mm.

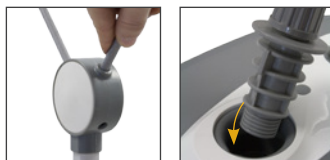

	QTY	N.W(kg)	G.W(kg)	C.B.M.	Size(mm)
Uni.	1	2.8	3.25	0.09	400x200x1080

10.573

900x1750mm



	QTY	N.W(kg)	G.W(kg)	C.B.M.	Size(mm)
Uni.	1	3	3.45	0.09	400x200x1080

10.574

900x1750mm



OUTDOOR BANNER

1

Outdoor Banner Charleroi

 Outdoor Banner, doppelseitig. Fuß mit Wasser oder Sand auffüllbar. Ideal für den Eingangsbereich von Geschäften, für Gärten, Bürgersteige, etc.

 Banner ideal for outdoor use like shop entrances, gardens, sidewalks, etc.. Double-sided. Base fillable with water or sand. Plastic.

 Banner double face avec base à remplir d'eau ou de sable. Idéal pour une utilisation à l'extérieur.

 Expositor dupla face fabricado em plástico. A sua base enche-se com água ou areia tornando-o estável e pesado. Ideal para colocar em parques, entradas de lojas e passeios.

 Banner de exterior ideal para uso en entradas de tiendas, jardines, aceras, etc. Doble cara. Base rellenable de agua o arena.

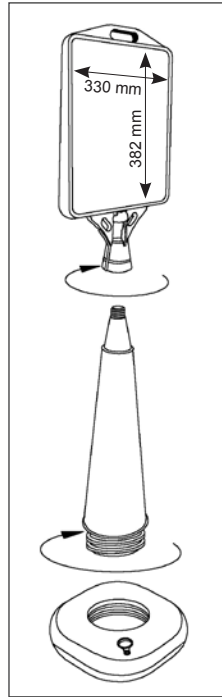

	QTY	N.W(kg)	G.W(kg)	C.B.M.	Size(mm)
Packing	1	2	2.5	0.07	500x200x690

10.248

330x382mm



Outdoor Banner Delta

 Kundenstopper aus Kunststoff, doppelseitig, geeignet für In- und Outdoor Bereich.

 Double-sided plastic stand. Outdoor - Indoor use. Plastic.

 Chevalet d'extérieur, double face, fabriqué en plastique.

 Cavalete em plástico de dupla face. Pode ser usado tanto no exterior como no interior.

 Caballete de exterior fabricado en plástico. Doble cara.



	QTY	N.W(kg)	G.W(kg)	C.B.M.	Size(mm)
Packing	1	7	8	0.05	630x80x1010

10.679

550x700mm



OUTDOOR BANNER

Yuste



6 kg Water

Mobiles Fahnenmastsystem für zwei Grafiken, aus Aluminium und Kunststofffuß, Outdoor Bereich, Werbeaussagen weithin sichtbar.

Outdoor flagpole. Can be used with two graphics. Water filled stand. Aluminium, plastic parts. Visible at a great distance.

Banderole extérieure en aluminium et base en plastique remplissable d'eau. Permet la visualisation des images à grand distance.

Mastro de exterior para a colocação de uma ou duas imagens. Possui uma base onde se pode colocar água. Fabricado em alumínio e plástico.

Banderola de exterior para dos gráficas promocionales. Realizado en aluminio y con base de plástico. Gráfica visible a gran distancia.

	QTY	N.W(kg)	G.W(kg)	C.B.M.	Size(mm)
Pole	1	1.35	1.85	0.015	120x80x1650
Base	1	0.95	1.15	0.017	260x200x340
10.709	600x1500-4500mm				



Brest



4.1m

50 kg Water

Mobiles Fahnenmastsystem mit Kunststofffuß, mit Wasser auffüllbar, einfache und schnelle Handhabung. höhenverstellbar bis 4,1 m.

Giant flagpole 4,1 meters high. Delivery with a heavy plastic foot which can be filled with 50kg of sand or water. Aluminium, plastic parts.

Banderole extérieure télescopique. Base en plastique remplissable d'eau. Facile à monter. Hauteur 4,1 m.

Mastro de grandes dimensões. Possui uma base que atinge um peso de 50 kg colocando água ou areia. Fabricado em alumínio e plástico. Altura total 4,1m.

Bandera para exteriores con base de plástico rellenable. Expositor telescópico y fácil montaje. Altura 4,1 m.

	QTY	N.W(kg)	G.W(kg)	C.B.M.	Size(mm)
Pole	1	4.1	5.1	0.029	135x135x1610
Base	1	6	6.3	0.117	665x265x665
10.652	800x2800mm				



OUTDOOR BANNER

1

Cergy

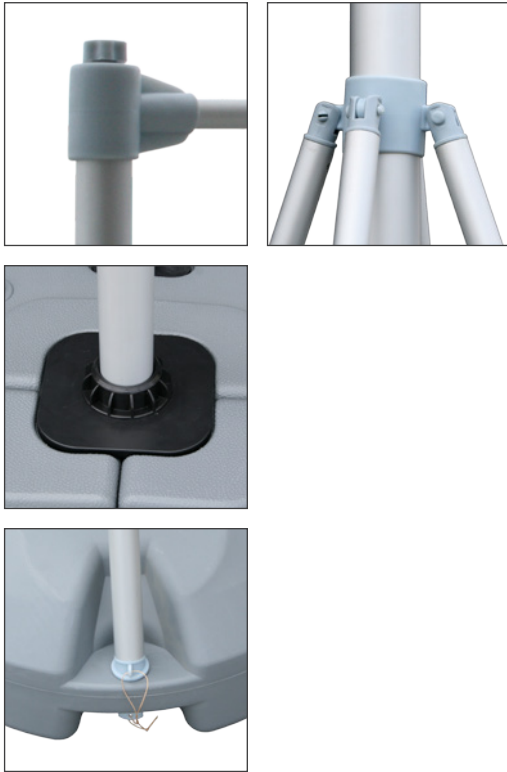

🇩🇪 Mobiles Fahnenmastsystem aus Aluminium und Kunststofffuß, mit Wasser auffüllbar, inklusive Kunststoffclips zur Befestigung der Grafik, Outdoor Bereich. Aussteller klappbar und höhenverstellbar.
 Ref: 10.577 Grafikgröße: ca. ± 1200x6000mm.
 Ref: 10.578 Grafikgröße: ca. ± 1200x7500mm.

🇬🇧 Giant flagpole of 7 or 9 meters high. Delivery with a heavy plastic foot which can be filled with sand or water. Aluminium, plastic parts.
 Ref: 10.577 graphic sizes: ± 1200x6000mm.
 Ref: 10.578 graphic sizes: ± 1200x7500mm.

🇫🇷 Mât de grande dimension pour drapeau, fabriqué en aluminium et plastique. Hauteur disponible en 7 ou 9 mètres. Possède une base, lourde, à remplir d'eau ou de sable.
 Ref: 10.577 format des visuels: ± 1200x6000mm.
 Ref: 10.578 format des visuels: ± 1200x7500mm.

🇧🇷 Mastros de grandes dimensões: 7 ou 9 metros. Possuem uma base ondes e pode colocar água. Fabricado em alumínio e plástico.
 Área de impressão Ref: 10.577 : ± 1200x6000 mm.
 Área de impressão Ref: 10.578 : ±1200x7500 mm.

🇪🇸 Bandera para exteriores con base de plástico, y soportes de plástico para la gráfica. Expositor plegable y telescópico fabricado en aluminio.
 Ref: 10.577 área gráfica: ± 1200x6000mm.
 Ref: 10.578 área gráfica: ± 1200x7500mm.



	QTY	N.W(kg)	G.W(kg)	C.B.M.	Size(mm)
Pole	1	6.5	7.5	0.03	150x130x1710
Base	1	8	9	0.13	410x410x805

10.577 1200x6000mm



	QTY	N.W(kg)	G.W(kg)	C.B.M.	Size(mm)
Pole	1	8.5	9.5	0.05	180x170x1710
Base	1	14	15	0.24	510x510x920

10.578 1200x7500mm





OUTDOOR BANNER

Bejar

 Mobiles Fahnenmastsystem mit Aluminiumstäben und Kunststofffuß, mit Wasser auffüllbar, inklusive Kunststoffclips zur Befestigung der Grafik, Outdoor Bereich. Aussteller klappbar und Höhe verstellbar. Grafikgröße: 1100x3500mm.

 Giant flagpole of 5 meters high. Delivery with a plastic foot which can be filled with 76 liters of sand or water. Telescopic banner, includes plastic clips for bottom graphics. Aluminium, plastic parts. Graphic size: 1100x3500mm.

 Mât de grande dimension pour drapeau, fabriqué en aluminium et plastique. Disponible en hauteur de 5 mètres. Possède une base avec une capacité de 76 litres. Format du visuel: 1100x3500mm.

 Masto de grandes dimensões. Possui uma base que atinge um peso de 76 kg, colocando água ou areia. Fabricado em alumínio e plástico. Área de impressão: 1100x3500mm.

 Bandera para exteriores con base de plástico, y soportes de plástico para la gráfica. Varillas de aluminio. Expositor plegable y telescópico. Área gráfica: 1100x3500mm.



	QTY	N.W(kg)	G.W(kg)	C.B.M.	Size(mm)
Pole	1	7.5	9.8	0.04	160x130x1680
Base	1	10	11	0.14	430x380x850
10.031	1100x3500mm				



OUTDOOR BANNER

1

Barahona - 1

Mobiles Präsentationssystem aus satiniertem Aluminium und Kunststoff, mit Wasser auffüllbar, doppelseitig. Empfohlene Befestigung der Grafik mittels Tunnelbund. Grafikgröße: 2500x2000mm.

A-Banner outdoor stand systems with water/sand fillable base offering impressive single or double-sided graphic displays. Aluminium, plastic parts. Graphic size: 2500x2000mm.

Banner double face équipé de réservoir en plastique. Fabriqué en aluminium satiné et plastique. Un revers est conseillé pour le montage. Format des visuels: 2500x2000mm.

Banner de exterior com reservatórios na base que se podem encher com água ou areia. Oferece um grande impacto visual tanto em simples como em dupla face. Área impressão: 2500x2000 mm.

Banner con bases rellenas, a doble cara, fabricado en aluminio satinado y plástico. Se recomienda el montaje de la gráfica mediante una "vaina". Área gráfica: 2500x2000mm.



Double-sided



25 kg Water

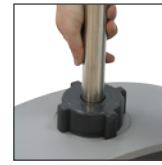
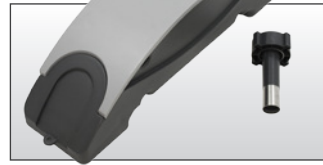

	QTY	N.W(kg)	G.W(kg)	C.B.M.	Size(mm)
Pole	1	11.5	16	0.04	410x210x1660
Base	1	8	9	0.11	430x310x850

10.030 2500x2000mm



Barahona - 2



Double-sided

Mobiles Präsentationssystem aus satiniertem Aluminium und Kunststoff, mit Wasser auffüllbar, doppelseitig. Empfohlene Befestigung der Grafik mittels Tunnelbund. Grafikgröße: 5640x2450mm.

Outdoor A-Banner stand system with water/sand fillable base offering impressive single or double-sided graphic displays. Aluminium and plastic parts. Graphic size: 5640x2450mm.

Banner double face équipé de réservoir en plastique. Fabriqué en aluminium satiné et plastique. Un revers est conseillé pour le montage. Format des visuels: 5640x2450mm.

Banner de exterior com reservatórios na base que se podem encher com água ou areia. Oferece um grande impacto visual tanto em simples como em dupla face. Área impressão: 5640x2450 mm.

Banner con bases rellenas, a doble cara, fabricado en aluminio satinado y plástico. Se recomienda el montaje de la gráfica mediante una "vaina". Área gráfica: 5640x2450mm.



25 kg Water

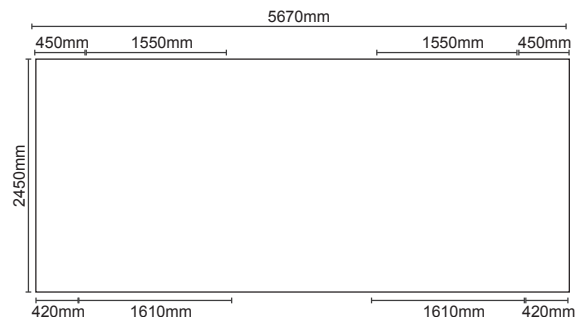





	QTY	N.W(kg)	G.W(kg)	C.B.M.	Size(mm)
Pole	1	17.2	21.1	0.044	170x150x1720
Base	1	13.30	18.3	0.12	470x300x850

10.830 5640x2450mm



FLYING BANNER

Narbona

-  Beachflag für Textilbanner mit befüllbarem Kunststofffuß.
-  Flying banner with a black plastic foot which can be filled with sand or water. Aluminium, fiberglass and plastic parts.
-  Drapeaux d'extérieur avec socle en plastique noir à remplir d'eau.
-  Mastro para exterior. Possui uma base com reservatório de água de cor preta. Fabricado em alumínio, fibra de vidro e plástico.
-  Bandera para banners en tela con base de plástico rellenable.

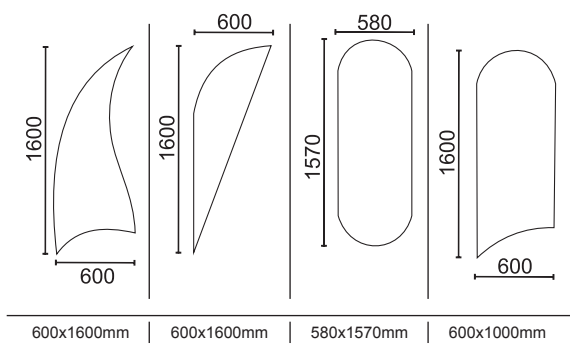
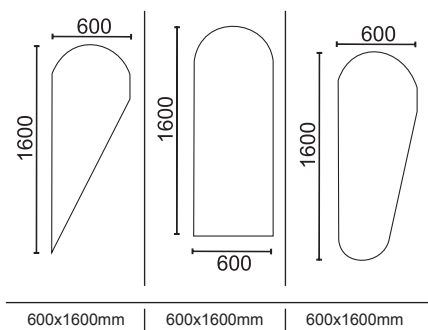
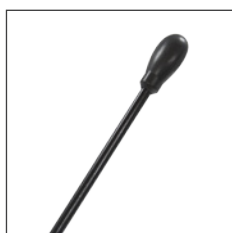

	QTY	N.W(kg)	G.W(kg)	C.B.M.	Size(mm)
Pole	20	7.8	13.33	0.108	280x270x1430
Base	8	8	10	0.213	750x380x750

10.651 ± 1600x600mm

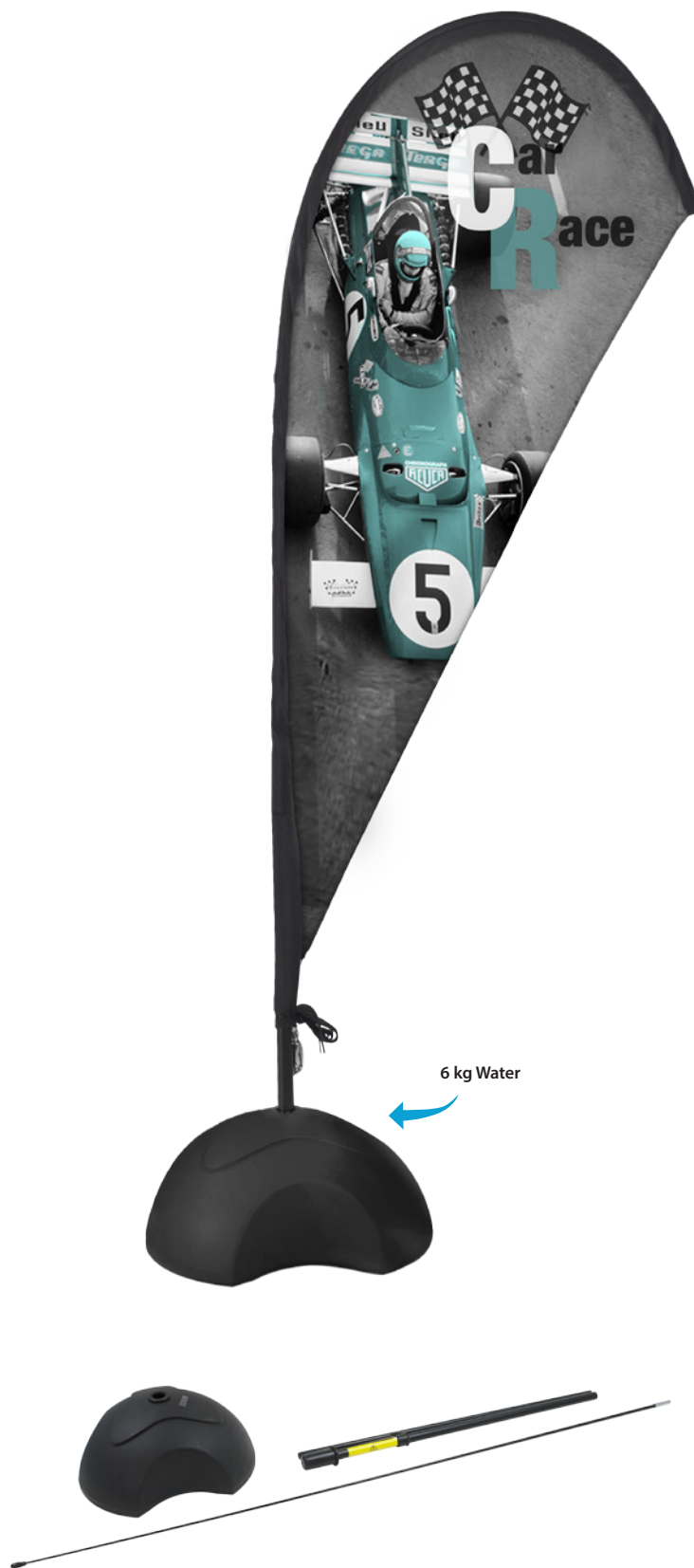



1

Flying Banner Spoon

Flying Bannerstange in 4 verschiedenen Farben erhältlich. Sie können unterschiedliche FüÙe dazu auswählen. Aluminium, Glasfaser und Kunststoffteile. Preis gilt für eine Stange.

Flying Banner pole. Available in 4 different sizes. You can choose different flying banner base feet. Aluminium, fiber glass and plastic parts. The price includes only the post.

Mât en aluminium, fibre de verre et plastique pour drapeaux. Disponible en 4 tailles différentes. Possibilité de choisir parmi plusieurs socles. Prix du mât.

Mastro para exterior disponível em 4 tamanhos e que se adapta a diferentes bases. Fabricado em alumínio, fibra de vidro e plástico. Preço do mastro.

Poste para Flying Banner. Disponible en 4 medidas. Puede combinarse con distintos tipos de bases. Fabricado en aluminio, fibra de vidrio y partes plásticas. Precio solo del poste.

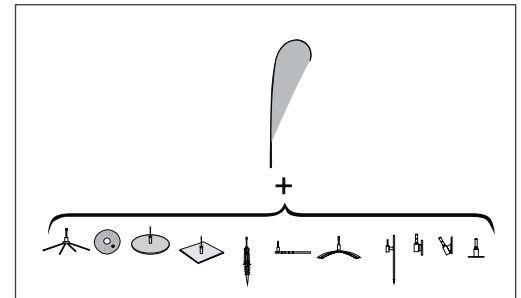

	QTY	N.W(kg)	G.W(kg)	C.B.M.	Size(mm)
Uni.	1	0.67	0.72	0.004	65x50x1410

13.600

Ⓢ



	QTY	N.W(kg)	G.W(kg)	C.B.M.	Size(mm)
Uni.	1	1.07	1.57	0.005	80x50x1410

13.601

Ⓜ



	QTY	N.W(kg)	G.W(kg)	C.B.M.	Size(mm)
Uni.	1	1.49	1.99	0.005	80x50x1410

13.602

Ⓛ



	QTY	N.W(kg)	G.W(kg)	C.B.M.	Size(mm)
Uni.	1	1.78	2.28	0.005	80x50x1410

13.603

ⓧ



Graphic Sizes:

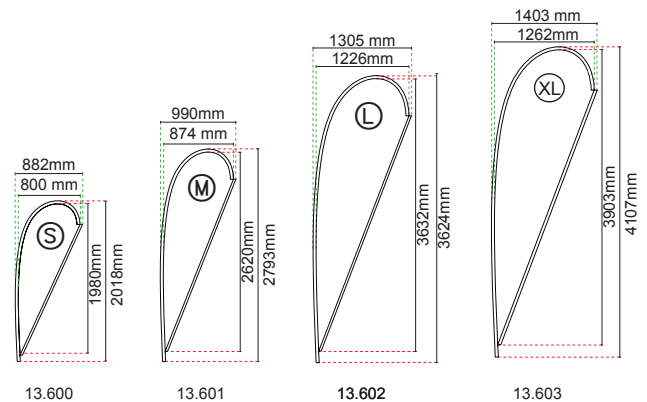



Flying Banner Knife

Flying Bannerstange in 4 verschiedenen Farben erhältlich. Sie können unterschiedliche Füße dazu auswählen. Aluminium, Glasfaser und Kunststoffteile. Preis gilt für eine Stange.

Flying Banner pole. Available in 4 different sizes. You can choose different flying banner base feet. Aluminium, fiber glass and plastic parts. The price includes only the post.

Mât en aluminium, fibre de verre et plastique pour drapeaux. Disponible en 4 tailles différentes. Possibilité de choisir parmi plusieurs socles. Prix du mât.

Mastro para exterior disponível em 4 tamanhos e que se adapta a diferentes bases. Fabricado em alumínio, fibra de vidro e plástico. Preço do mastro.

Poste para Flying Banner. Disponible en 4 medidas. Puede combinarse con distintos tipos de bases. Fabricado en aluminio, fibra de vidrio y partes plásticas. Precio solo del poste.

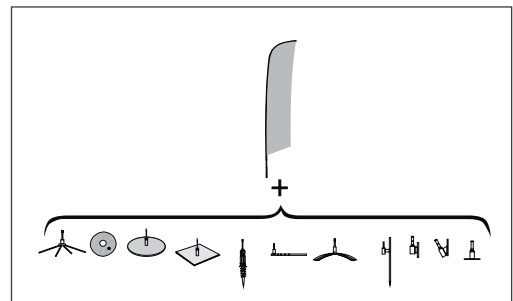

	QTY	N.W(kg)	G.W(kg)	C.B.M.	Size(mm)
Uni.	1	0.94	1.44	0.005	80x50x1410

13.604

Ⓢ



	QTY	N.W(kg)	G.W(kg)	C.B.M.	Size(mm)
Uni.	1	1.15	1.65	0.005	80x50x1410

13.605

Ⓜ



	QTY	N.W(kg)	G.W(kg)	C.B.M.	Size(mm)
Uni.	1	1.60	2.10	0.005	80x50x1410

13.606

Ⓛ



	QTY	N.W(kg)	G.W(kg)	C.B.M.	Size(mm)
Uni.	1	1.65	2.15	0.006	90x50x1410

13.607

ⓧ



Graphic Sizes:

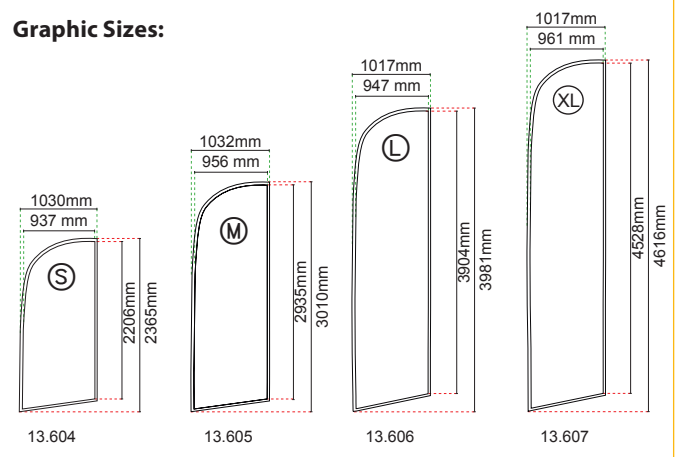

1

Flying Banner Square



Flying Bannerstange in 3 verschiedenen Farben erhältlich. Sie können unterschiedliche Füße dazu auswählen. Aluminium, Glasfaser und Kunststoffteile. Preis gilt für eine Stange.

Flying Banner Pole. Available in 3 different sizes. You can choose different flying banner base feet. Aluminium, fiberglass and plastic parts. The price includes only the post.

Mât en aluminium, fibre de verre et plastique pour drapeaux. Disponible en 3 tailles différentes. Possibilité de choisir parmi plusieurs socles. Prix du mât.

Mastro para exterior disponível em 3 tamanhos e que se adapta a diferentes bases. Fabricado em alumínio, fibra de vidro e plástico. Preço do mastro.

Poste para Flying Banner. Disponible en 3 medidas. Puede combinarse con distintos tipos de bases. Fabricado en aluminio, fibra de vidrio y partes plásticas. Precio solo del poste.

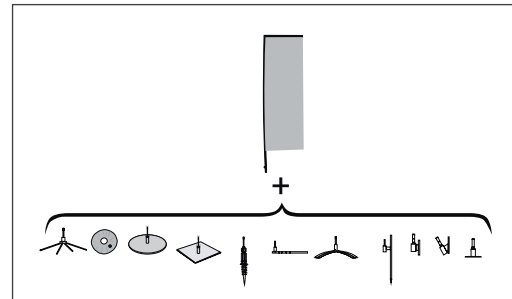

	QTY	N.W(kg)	G.W(kg)	C.B.M.	Size(mm)	
13.608	Uni. 1	0.94	1.44	0.004	80x50x1050	
13.609	Uni. 1	1.46	1.96	0.005	100x50x1050	
13.610	Uni. 1	1.80	2.30	0.005	100x50x1050	

Graphic Sizes:

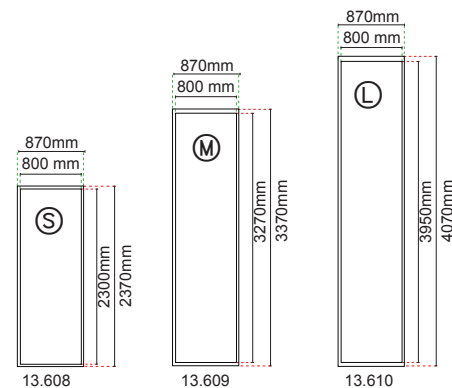

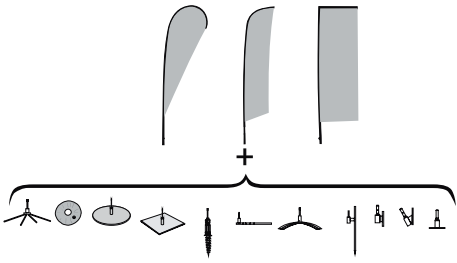

Cross Base Flying Banner with Water Plast Bag

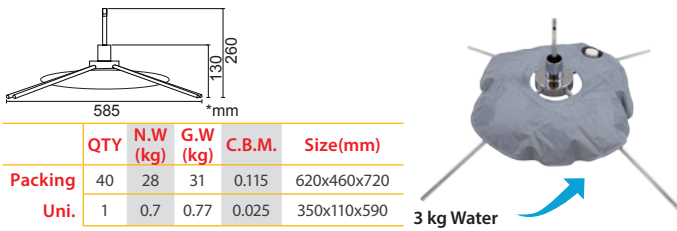

	QTY	N.W (kg)	G.W (kg)	C.B.M.	Size(mm)
Packing	40	28	31	0.115	620x460x720
Uni.	1	0.7	0.77	0.025	350x110x590

13.611

Water Plast Bag

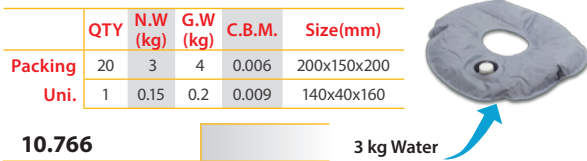

	QTY	N.W (kg)	G.W (kg)	C.B.M.	Size(mm)
Packing	20	3	4	0.006	200x150x200
Uni.	1	0.15	0.2	0.009	140x40x160

10.766

Ground Drill Flying Banner

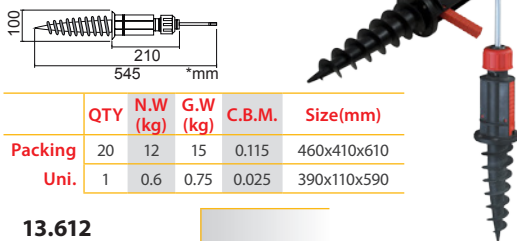

	QTY	N.W (kg)	G.W (kg)	C.B.M.	Size(mm)
Packing	20	12	15	0.115	460x410x610
Uni.	1	0.6	0.75	0.025	390x110x590

13.612

Round Straight Spike Flying Banner

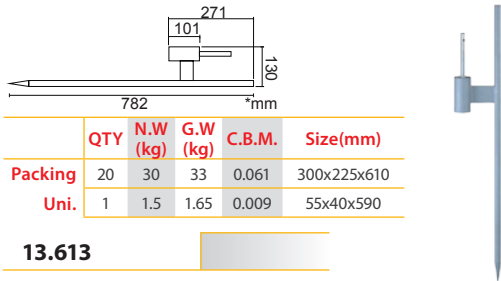

	QTY	N.W (kg)	G.W (kg)	C.B.M.	Size(mm)
Packing	20	30	33	0.061	300x225x610
Uni.	1	1.5	1.65	0.009	55x40x590

13.613

Plate Cross Base Flying Banner

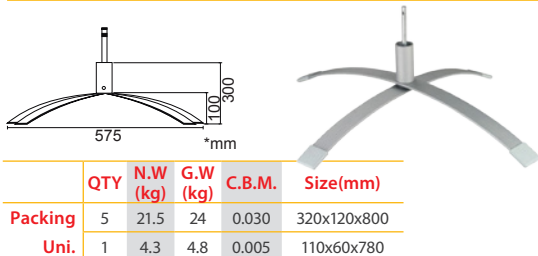

	QTY	N.W (kg)	G.W (kg)	C.B.M.	Size(mm)
Packing	5	21.5	24	0.030	320x120x800
Uni.	1	4.3	4.8	0.005	110x60x780

13.617

Tire Base U Style Flying Banner

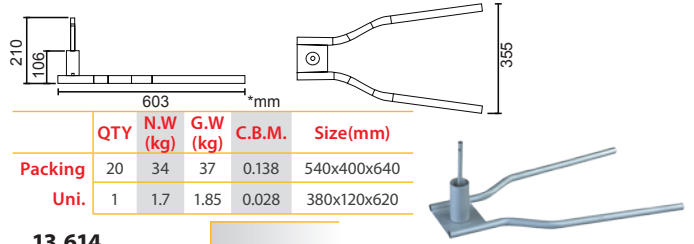

	QTY	N.W (kg)	G.W (kg)	C.B.M.	Size(mm)
Packing	20	34	37	0.138	540x400x640
Uni.	1	1.7	1.85	0.028	380x120x620

13.614

Round Plate Base Flying Banner

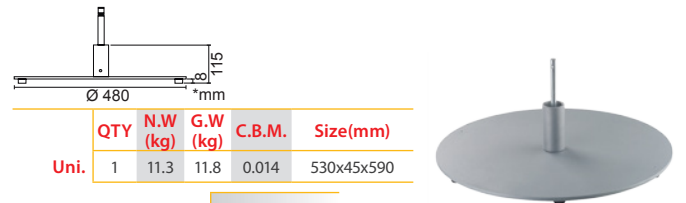

	QTY	N.W (kg)	G.W (kg)	C.B.M.	Size(mm)
Uni.	1	11.3	11.8	0.014	530x45x590

13.615

Square Plate Base Flying Banner

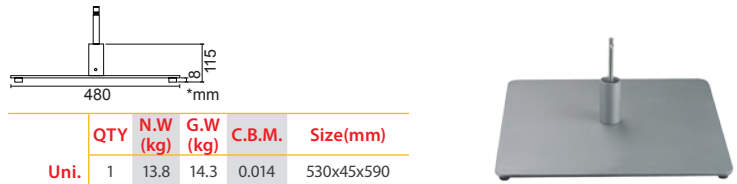

	QTY	N.W (kg)	G.W (kg)	C.B.M.	Size(mm)
Uni.	1	13.8	14.3	0.014	530x45x590

13.616

Fixed mount 0°

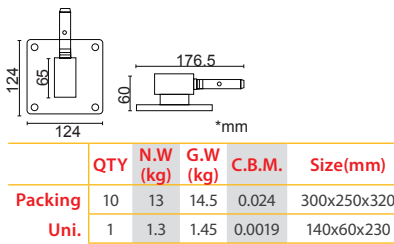

	QTY	N.W (kg)	G.W (kg)	C.B.M.	Size(mm)
Packing	10	13	14.5	0.024	300x250x320
Uni.	1	1.3	1.45	0.0019	140x60x230

13.618

Fixed mount 30°

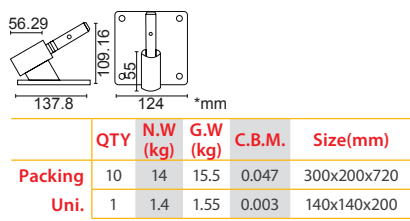

	QTY	N.W (kg)	G.W (kg)	C.B.M.	Size(mm)
Packing	10	14	15.5	0.047	300x200x720
Uni.	1	1.4	1.55	0.003	140x140x200

13.619

Fixed mount 90°

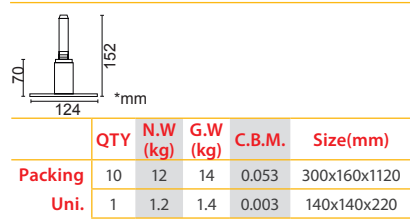

	QTY	N.W (kg)	G.W (kg)	C.B.M.	Size(mm)
Packing	10	12	14	0.053	300x160x1120
Uni.	1	1.2	1.4	0.003	140x140x220

13.620

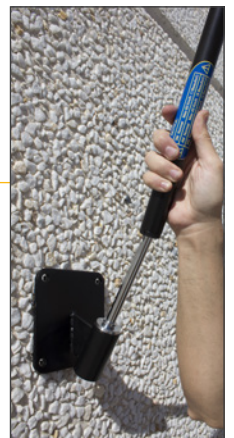

STREET BANNER

1

Street Banner Pole

🇩🇪 Befestigungssystem für Outdoor-Grafiken z.B.an Außenwänden oder Lampen. Für stärkere Windverhältnisse ausgelegt.

🇬🇧 Banner flag system for wall, lamps or another outdoor post. This support is designed for strong wind conditions.

🇫🇷 Support drapeaux pour l'extérieur adaptable sur mur ou poteaux.

🇵🇹 Sistema de bandeirala para parede, postes ou outro sistema de exterior. Este suporte foi desenhado para suportar ventos fortes.

🇪🇸 Soporte de gráfica para exterior. Permite la colocación sobre paredes o postes de exterior.

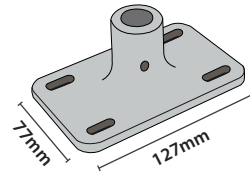

Screw

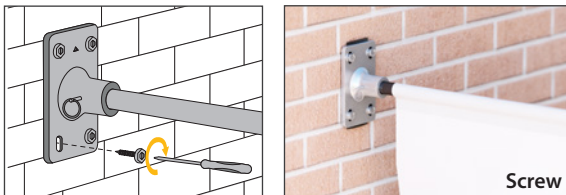

Screw

10.202	Pole 800mm	
10.203	Pole 1000mm	
10.204	Pole 1200mm	

Hose Clamps

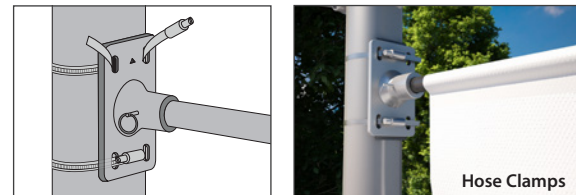

Hose Clamps

10.071	Pole 800mm	
10.072	Pole 1000mm	
10.073	Pole 1200mm	

Mini Street Banner

🇩🇪 Metallteile für Wand. Für stärkere Windverhältnisse ausgelegt 120g.

🇬🇧 Mini street wall space. This support is designed for stronger wind conditions. Metal.

🇫🇷 Support visuel de petite dimension pour l'extérieur. Adaptable sur mur ou poteaux.

🇵🇹 Mini fixador de parede em metal. Este suporte foi desenhado para suportar ventos fortes.

🇪🇸 Soporte de reducido tamaño para colocación de gráfica en exterior. Permite la colocación sobre paredes o postes.

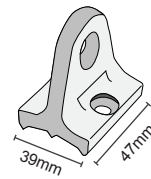

Screw

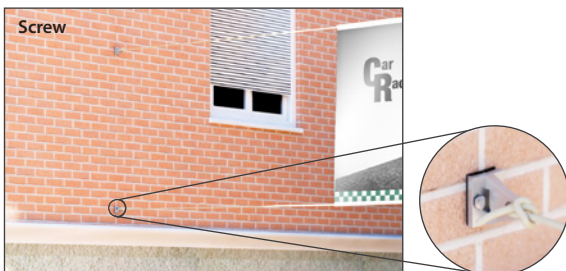
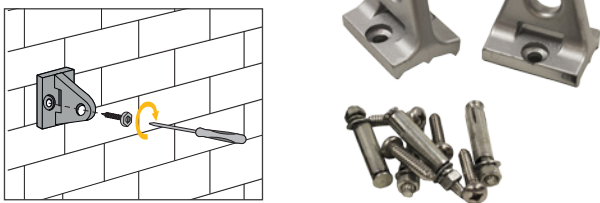

Screw

10.100	Screw	
--------	-------	--

Hose Clamps

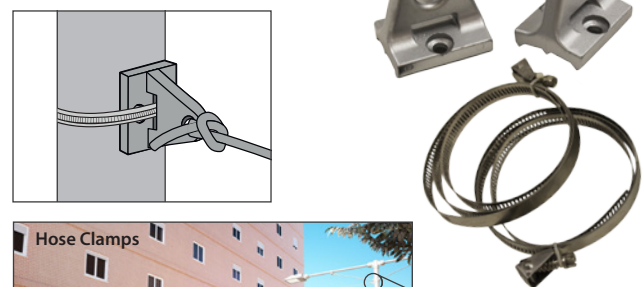

Hose Clamps

10.099	Hose Clamps	
--------	-------------	--

Lamp System

 Auslegersystem zum befestigen an Masten oder anderen Pfosten. Hält auch starkem Wind Stand. Aluminium, Kunststoff-Teile. Enthalten ist:

- 1 Aluminium Klammer.
- 1 Pin und 1 Ring.
- 2 Edelstahl-Bänder.
- 1 Ausleger aus Fiberglas in 600mm oder 1000mm.

 Banner flag system for lamp or another outdoor post. This support is designed for strong wind conditions. Aluminium, plastic parts. Each kit includes:

- 1 aluminium bracket.
- 1 pin and 1 ring.
- 2 stainless steel band.
- 1 fiberglass pole 600 or 1000mm length.

 Potence de rue pour des poteaux à l'extérieur. Cette structure a été conçue pour supporter des vents forts. Chaque kit inclus:

- Une pièce d'aluminium pour la fixation au poteau.
- Une goupille avec rondelle.
- 2 attaches d'acier.
- Un poteau en fibre de verre de 600 mm ou 1000mm.

 Sistema de bandeirola para postes. Este suporte foi desenhado para suportar ventos fortes. Fabricado em alumínio e plástico. Cada kit inclui:

- 1 Suporte.
- 2 Abraçadeiras.
- 1 Poste de fibra de vidros de 600 ou 1000 mm.
- Conectores.

 Soporte para la colocación de material gráfico sobre farolas, mástiles, postes, etc. Cada kit incluye:

- 1 Pieza de aluminio para suspensión a poste.
- 1 Pasador con 1 anilla.
- 2 Abrazaderas de acero.
- 1 Poste de fibra de vidrio de 600 a 1000mm.

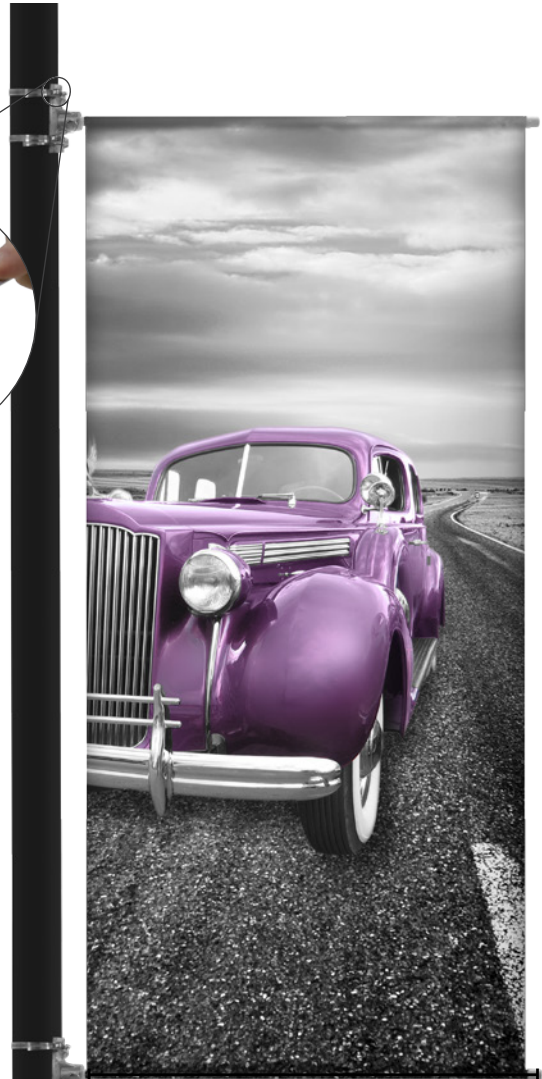
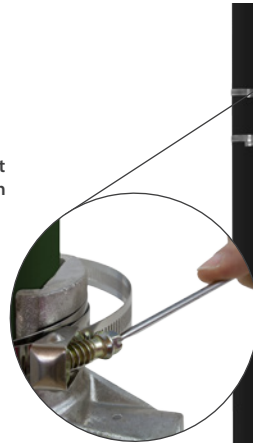

12.454 - 600mm
12.353 - 1000mm

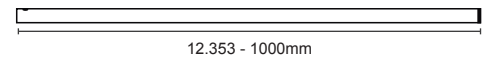
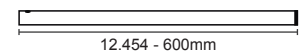

Kit: Ø 20mm

	QTY	N.W(kg)	G.W(kg)	C.B.M.	Size(mm)
Uni.	1	0.6	1	0.0039	100x65x610

12.454 Pole 600mm

	QTY	N.W(kg)	G.W(kg)	C.B.M.	Size(mm)
Uni.	1	1	1.35	0.006	100x65x1010

12.353 Pole 1000mm

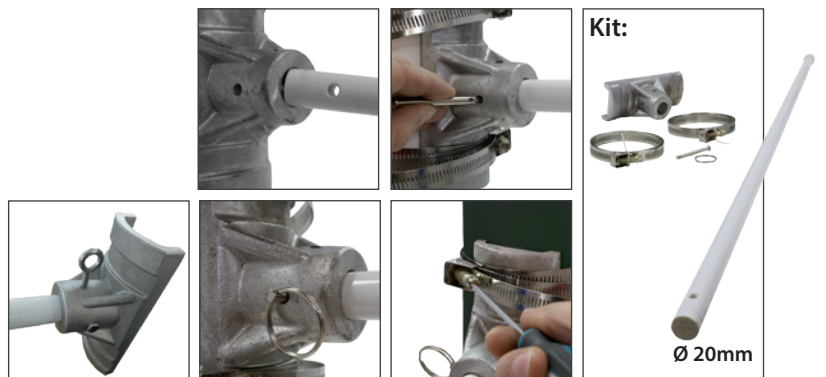

Kit:

Ø 20mm

FLAGS SYSTEM

1

Wall Pole

Verankerungssystem für die Wand. Material: Edelstahl.

Stainless steel anchoring wall system.

Système d'ancrage mural en acier inoxydable.

Bandeirola com sistema de fixação à parede fabricado em aço inoxidável.

Sistema de anclaje a pared en acero inoxidable.

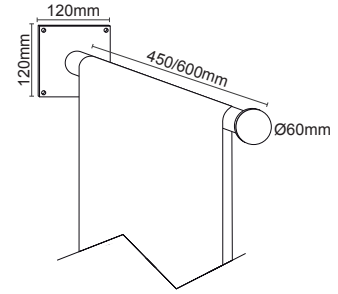

	QTY	N.W(kg)	G.Wv(kg)	C.B.M.	Size(mm)
Packing	2	2.20	2.64	0.0112	160x130x540

10.453 **Ø40x450mm**

	QTY	N.W(kg)	G.Wv(kg)	C.B.M.	Size(mm)
Packing	2	2.46	3.00	0.0139	160x130x670

10.454 **Ø40x600mm**

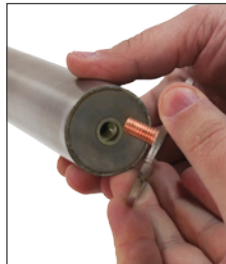

Holder

Verankerungssystem für die Wand. Material: Aluminium oder Nylon.

Anchoring wall system. Aluminium or Nylon.

Système d'encrage mural en aluminium ou nylon.

Sistema para colocação de bandeirolas em paredes, fabricado em alumínio ou nylon.

Sistema de anclaje a pared. Aluminio o Nylon.

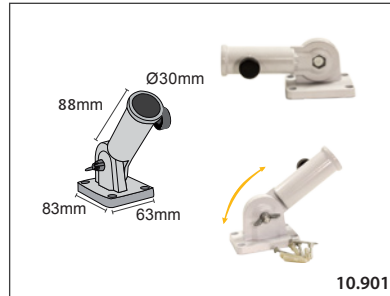

10.901

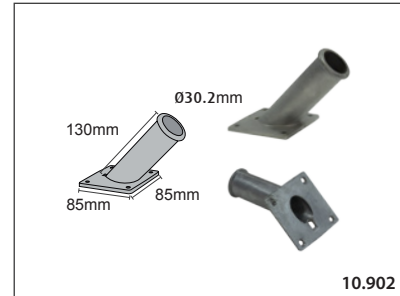

10.902

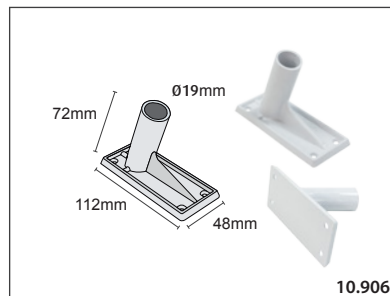

10.906

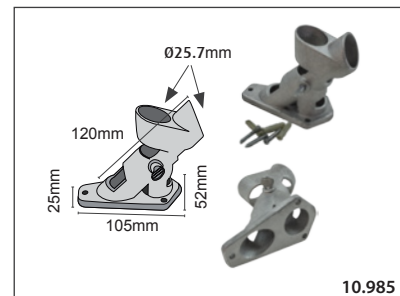

10.985



10.901	Ø 30mm	
10.902	Ø 30.2mm	
10.906	Ø 19mm	
10.985	Ø 25.7mm	

FLAGS SYSTEM

Standard Flags System

🇩🇪 Flaggen aus hochwertigem Polyester. Für den Außen- und Innenbereich. Polyester 120g.

🇬🇧 Flags made in high quality polyester. Suitable for indoor and outdoor use. Material: Polyester 120 g.

🇫🇷 Drapeaux en polyester de haute qualité pour une utilisation à l'intérieur ou à l'extérieur. Polyester de 120g.

🇵🇹 Bandeiras fabricadas em poliéster de alta qualidade. Adequado para interior ou exterior. Poliéster 120g.

🇪🇸 Banderas de poliéster de alta calidad. Adequado para interior y exterior. Material: Poliéster 120g.

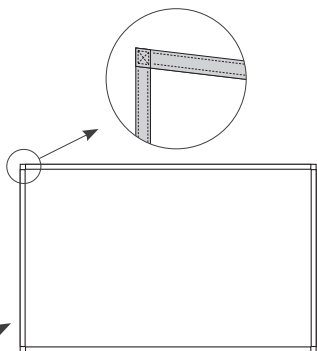

C.E

		Without Technical	1	2	4	5	7	3	6
10.379	700x1000mm								
10.882	1500x1000mm								
10.883	2000x1200mm								
10.884	2500x1500mm								

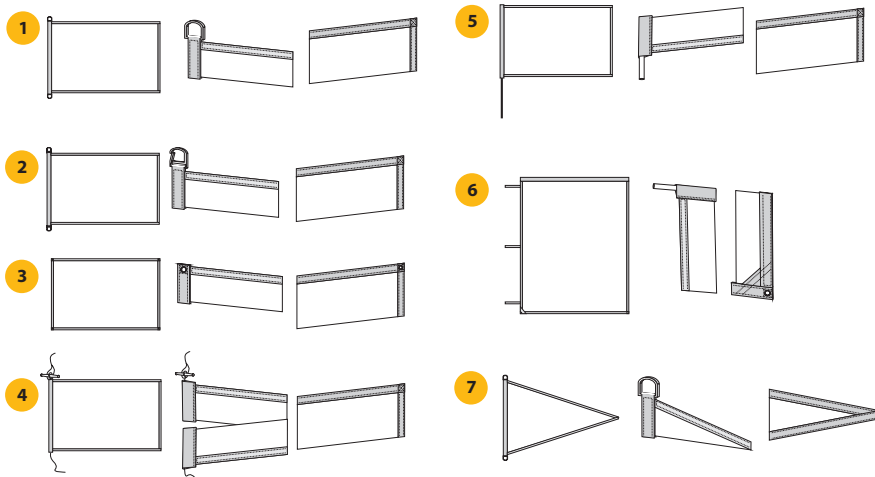

* C.E. Flaggen / C.E. Flags / C.E. Drapeaux / C.E. Bandeiras / C.E. Banderas



FLAGS SYSTEM

1

Request Flags System

🇺🇹 Flaggen aus hochwertigem Polyester. Für den Außen- und Innenbereich. Material: Polyester.

🇺🇹 Flags made in high quality polyester. Suitable for indoor & outdoor use. Material: Polyester.

🇺🇹 Drapeaux en polyester de haute qualité pour une utilisation à l'intérieur ou à l'extérieur.

🇺🇹 Bandeiras fabricadas em poliéster de alta qualidade. Adequado para interior ou exterior. Material: Poliéster.

🇺🇹 Banderas de poliéster de alta calidad. Adequado para interior y exterior. Material: Poliéster.



Armenia



Australia



Bahrain



Barbados



Bhutan



Brazil



Brunei



Burkina Faso



Burundi



Cambodia



Cameroon



Canada

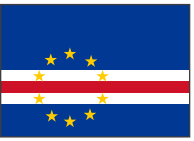

Cape Verde



Central African Rep.



Chad



Chile



Colombia



Comoros



Cuba



Djibouti



Dominica



Dominican Rep.



East Timor



Ecuador



Egypt



El Salvador



Equatorial Guinea



Eritrea



Ethiopia



Fiji



Gabon



Gambia



Guatemalan



Guinea



Guyana



Haiti



Honduras



Jamaica



Japan



Jordan



Indonesia



Iran



Isle of Man

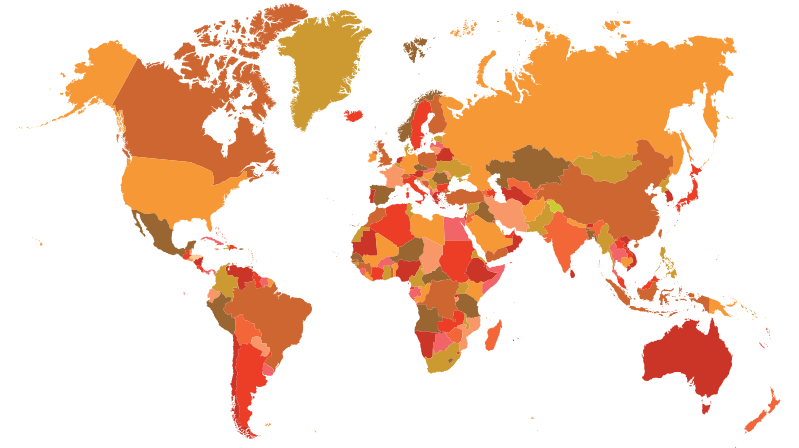

FLAGS SYSTEM

Request Flags System



Internationals

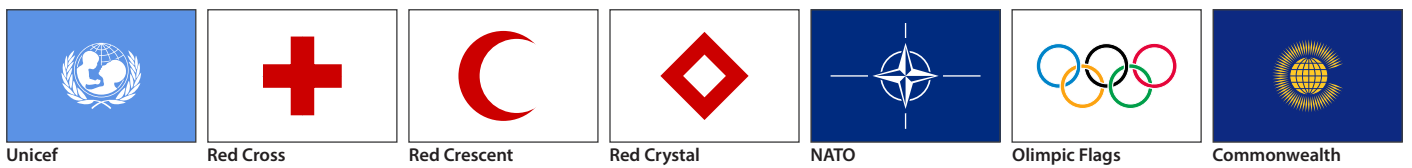

Enterprises



Universities

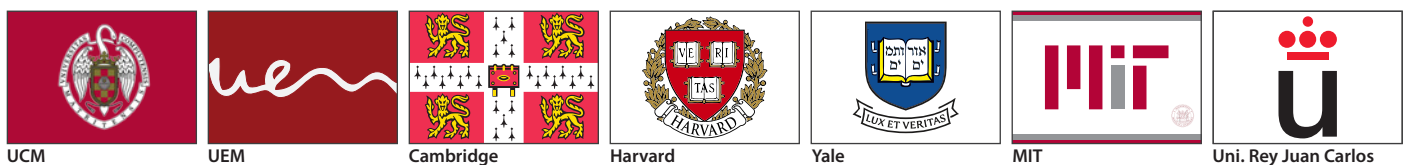

Sports

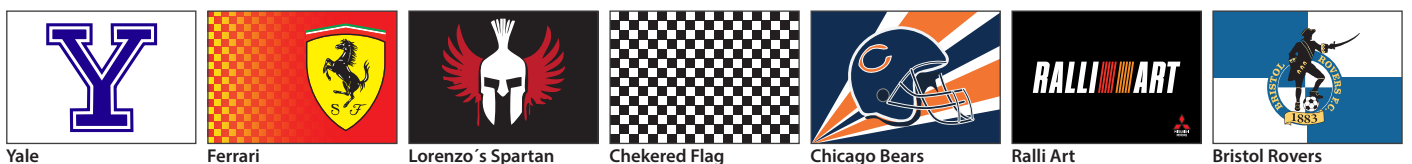

BARRIER BANNER - EXHIBITION WALL

1

Barrier Banner

Aluminiumrahmen, Lieferung inklusive Transporttasche, Haken und Schlaufen zur Befestigung der Grafik und Verankerung für weiche Böden, Montage erfordert keine Werkzeuge. Größe: 2470x955mm.

Consists of aluminium frame, loops, hooks for fixing the digitally printed banner and tent pegs for fixing the frame in soft ground. No tools required for assembly. Aluminium. Price includes bag. Size: 2470x955mm.

Cadre en aluminium pour l'exposition de visuel. Nœuds et crochets inclus pour la fixation des impressions et cheville pour la fixation sur sol mou. Le montage ne nécessite aucun outil. House de transport incluse. Dimensions: 2470x955mm.

Estrutura consistente fabricada em alumínio. Inclui laços e ganchos para colocar a impressão e cravelhas para fixar a estrutura a solos arenosos. Não necessita de ferramentas para a sua montagem. Inclui bolsa de transporte. Dimensões: 2470x955mm.

Marco de aluminio para exposición de gráfica. Incluye lazos, ganchos para la fijación de las impresiones y clavijas para fijar el marco en el suelo blando. No se requieren herramientas para el montaje. Incluye bolsa de transporte. Material: aluminio. Tamaño: 2470x955mm.

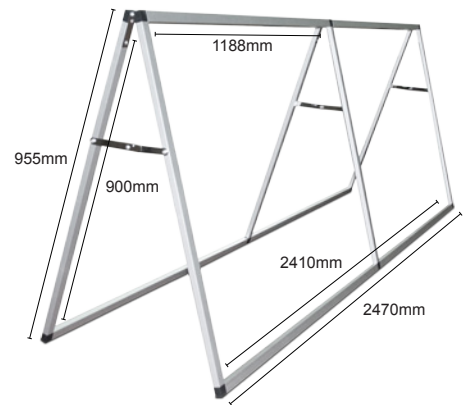

	QTY	N.W(kg)	G.W(kg)	C.B.M.	Size(mm)
Uni.	1	7	8,1	0,049	200x200x1220
10.548		2410x900mm			



Exhibition Wall Arenas

Präsentationswand als Faltsystem, aus Aluminium und Kunststoff, 8 Feld je 600x900mm. Ideal für Präsentation Ihres Produktes auf Pressekonferenzen. Grafikgröße: 538x845mm / Felder.

Folding panel kit. Quick and easy to assemble. Composed by 8 pieces of 600x900mm. Aluminium, plastic parts. Graphic size: 538x845mm for each panel.

Mur modulaire pour présentation. Composé de 8 pièces de 600x900mm. Idéal pour la présentation de produits, conférences de presse, etc. Format visuel: 538x845mm / panneau.

Biombo modular de fácil montagem composto por oito painéis de 600x900 mm. Fabricado em alumínio e plástico. Tamanho: 538x845 mm cada painel.

Muro modular para presentaciones. Compuesto por 8 piezas de 600x900mm. Ideal para presentaciones de producto, para promociones en ruedas de prensa, etc. Área gráfica: 538x845mm / panel.

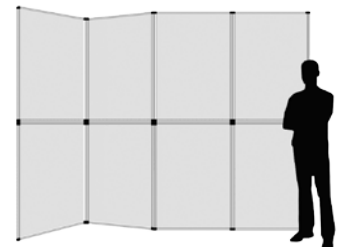

	QTY	N.W(kg)	G.W(kg)	C.B.M.	Size(mm)
Packing	1	7,3	11	0,12	640x200x950
10.041		2400x1800mm			



Pop-Up Fashion Cumbre

Extravagantes Pop-Up in Dreiecksform aus Aluminiumstäben mit Magnetverschlüssen. Die individuelle Gestaltung belebt jeden Verkaufsstand.

Pop-Up Fashion "triangle" with stretch-prints gives a 3-D effect. New printing technology for fabric. Ideal for promotion in points of sale and events. Aluminium.

Pop-Up de forme triangulaire pour promotion et animation sur lieu de vente. Structure en aluminium et fermoir magnétique. Permet d'accrocher différents visuels en différentes configurations. Idéal pour le tissu.

Pop-Up de forma triangular para promoção e animação de um ponto de venda. Estrutura em alumínio com fecho magnético. Permite a colocação de diferentes impressões e configurações. Ideal para material têxtil.

Pop-Up de forma triangular para promoción y animación del punto de venta. Estructura de aluminio y cierre magnético. Permite la colocación de distintas gráficas y configuraciones. Ideal para material textil.

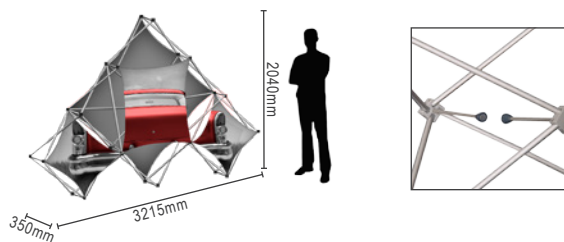

	QTY	N.W(kg)	G.W(kg)	C.B.M.	Size(mm)
Packing	1	6.2	7.7	0.05	240x240x840
10.423	3215x2040x350mm				



Pop-Up Fashion Alia



Präsentationsturm aus Aluminiumstäben mit Magnetverschlüssen, kreative Präsentationen auf kleinster Fläche.

Pop-Up Fashion "column" with stretch-prints gives a 3-D effect. New printing technology for fabric. Ideal for promotion in the point of sale and events. Aluminium.

Colonne promotionnelle Pop-Up. Idéale pour les espaces réduits, événements, promotions, etc. Fabriquée en aluminium avec fermoir magnétique. Idéal pour tissu.

Coluna promocional Pop-Up. Ideal para a animação de espaços reduzidos, apresentações, eventos, entre outros. Fabricado em alumínio com fecho magnético. Ideal para material têxtil.

Columna promocional Pop-Up. Ideal para la animación de espacios reducidos en presentaciones, eventos, etc. Fabricado en aluminio y con cierre magnético. Ideal para material textil.

	QTY	N.W(kg)	G.W(kg)	C.B.M.	Size(mm)
Packing	1	5	6.5	0.03	190x190x830
10.424	2215x770x350mm				



Totem Pop-Up Villoria

Präsentationssäule, kreative Präsentationen auf kleinster Fläche. Abmaße Rahmen: 600x2300mm. Grafikgröße: 637x2300mm x3 Felder.

Pop-Up exhibition stand Tower. Aluminium. Display size: 600x2300mm. Graphic size: 637x2300mm x3 panels.

Totem promotionnel magnétique. Dimension du support : 600x2300mm. Mesure des visuels : 637x2300mm x 3 panneaux.

Pop-Up circular fabricado em alumínio. Medidas de suporte: 600x2300mm. Medidas da impressão: 637x2300x 3 painéis.

Tótem promocional para gráfica. Medidas del soporte: 600x2300mm. Tamaño de la gráfica: 637x2300mm x3 paneles.

	QTY	N.W(kg)	G.W(kg)	C.B.M.	Size(mm)
Packing	1	9	12	0.08	350x250x850
10.040	637x2300mm				



VELCRO POP-UP

1

 Präsentationswand als Scherengittersystem, aus silberfarbenem Aluminium, schneller und einfacher Austausch der Grafik mittels Klettbefestigung. Inklusive:

- Transporttasche Nylon, Typ Trolley.
- Klettband.
- 2 Lichtspots.

 Straight graphic promo for Wall. The graph can be replaced quickly thanks to its velcro. Made of aluminum with silver finishing color. Contains:

- Trolley carry bag.
- Roll of Velcro.
- 2 Spotlights.

 Mur promotionnel droit. Le visuel peut être changé rapidement grâce à son système velcro. Fabriqué en aluminium avec finition couleur argent. Inclus:

- Valise type Trolley en nylon.
- Rouleau de velcro.
- 2 Foyers d'éclairage.

 Pop-Up com sistema de velcro que permite a mudança de imagem de forma fácil e rápida. Fabricado em alumínio com acabamento prateado. Conteúdo:



- Mala em tecido tipo carinho.
- Rolo de velcro.
- 2 Focos de Iluminação.

 Muro promocional recto para gráfica. La gráfica puede ser sustituida de forma rápida gracias a su sistema de velcro. Fabricado en aluminio con acabado en color plata. Contiene:

- Maleta tela tipo Trolley.
- Rollo de velcro.
- 2 Focos de Iluminación.

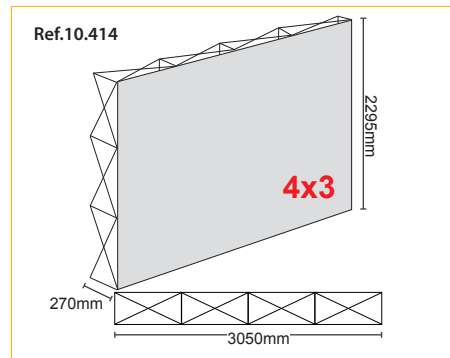
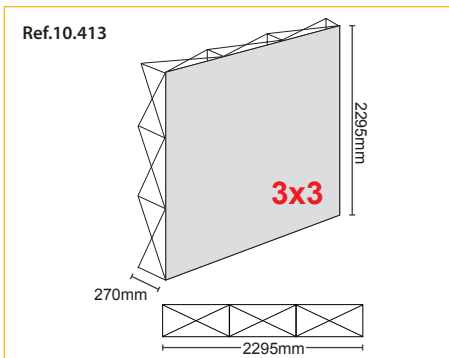
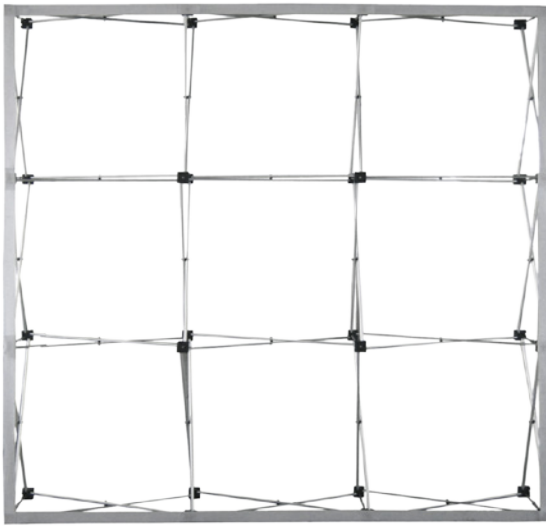
Pop-Up Cangas 3x3 - 4x3



	QTY	N.W(kg)	G.W(kg)	C.B.M.	Size(mm)
Packing	1	13.20	15	0.2	450x450x950
10.413	3x3	2295x2295mm	 		

	QTY	N.W(kg)	G.W(kg)	C.B.M.	Size(mm)
Packing	1	16.35	17.95	0.2	450x450x950
10.414	4x3	3050x2295mm	 		

VELCRO POP-UP

Pop-Up Cangas 5x3 - 6x3 - 7x3

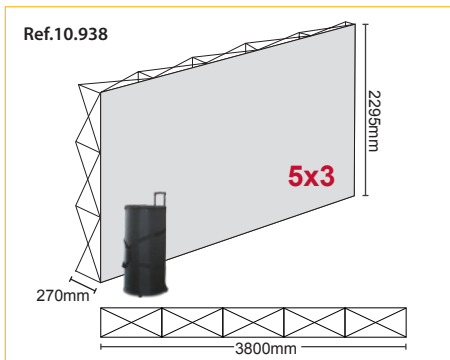

	QTY	N.W(kg)	G.W(kg)	C.B.M.	Size(mm)
Packing	1	16.95	18.30	0.201	460x460x950

10.938 **5x3** **3800x2295mm**

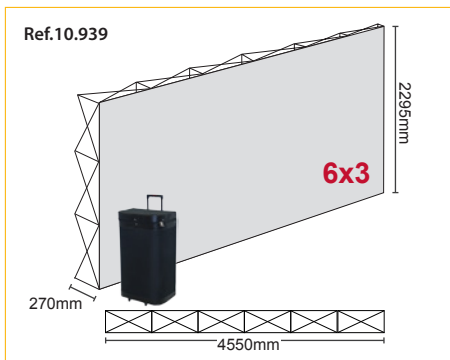

	QTY	N.W(kg)	G.W(kg)	C.B.M.	Size(mm)
Packing	1	20.50	21.90	0.200	540x400x950

10.939 **6x3** **4550x2295mm**

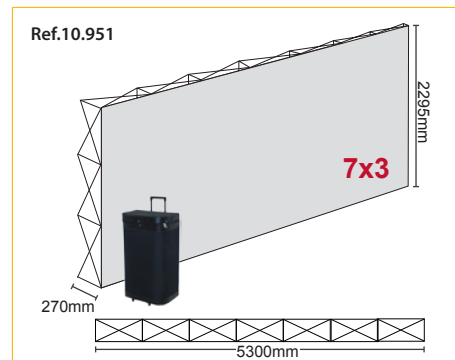

	QTY	N.W(kg)	G.W(kg)	C.B.M.	Size(mm)
Packing	1	22.65	24.50	0.201	540x400x950

10.951 **7x3** **5300x2295mm**



- Präsentationswand als Scherengittersystem aus Aluminium, gerade oder gebogene Form. Inklusive:
 - Transporttasche.
 - Magnetband / Magnetschienen.
 - Aufhänger.
 - Retira Füße.
 - 2 Lichtspots.

- Aluminium flexible Pop-Up adapted for curved or straight wall system is made of a foldable tube construction. Quick and easy assembly. The kit includes:
 - Trolley carry bag.
 - Magnetic strip roll.
 - Hangers / Magnetics bars.
 - 2 Spotlights.

- Mur promotionnel droit ou courbé en aluminium. Inclus:
 - Valise type Trolley en nylon.
 - Bandes de suspension / barres magnétiques.
 - 2 foyers d'éclairage.

- Painel promocional recto ou curvo para impressão. Estrutura em alumínio.
 - Conteúdo:
 - Mala de tecido tipo Trolley.
 - Rolo de íman.
 - Tiras de suspensão / Barras Magnéticas.
 - 2 Focos de iluminação.

- Muros promocionales rectos o curvos para gráficas. Estructura en aluminio.
 - Contenido:
 - Maleta tela tipo Trolley.
 - Rollo de ímán.
 - Perchas / Barras Magnéticas.
 - 2 Focos de Iluminación.

Pop-Up Laredo 3x3

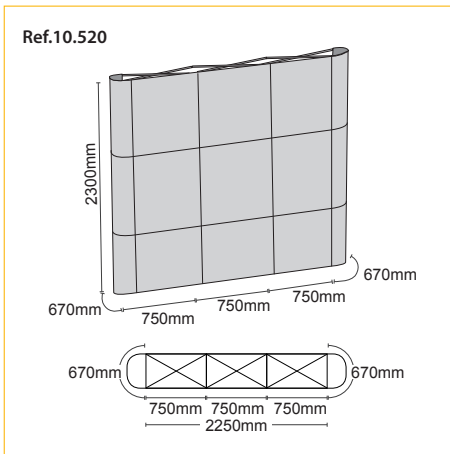

	QTY	N.W(kg)	G.W(kg)	C.B.M.	Size(mm)
Packing	1	17.15	18.6	0.12	390x340x920

10.520 670x2300mm x2
750x2300mm x3

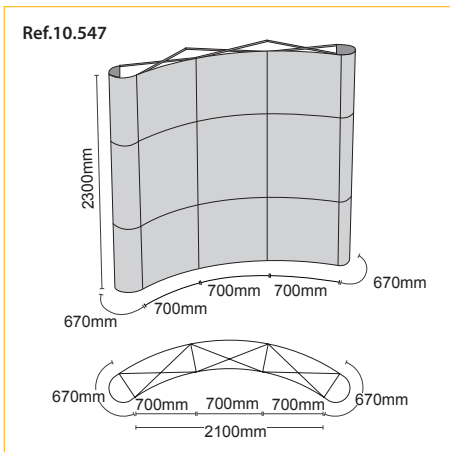

	QTY	N.W(kg)	G.W(kg)	C.B.M.	Size(mm)
ing	1	17.15	18.6	0.12	390x340x920

10.547 670x2300mm x2
700x2300mm x3



Pop-Up Llanes 4x3



Ref.10.513

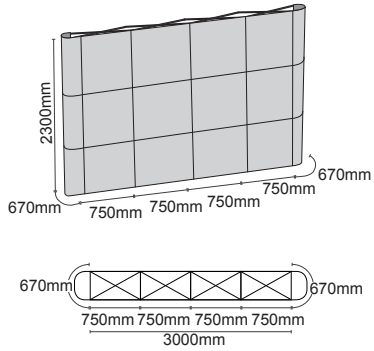

	QTY	N.W(kg)	G.W(kg)	C.B.M.	Size(mm)
Packing	1	21.7	22.1	0.12	390x340x920
10.513	670x2300mm x2				
	750x2300mm x4				



Ref.10.519

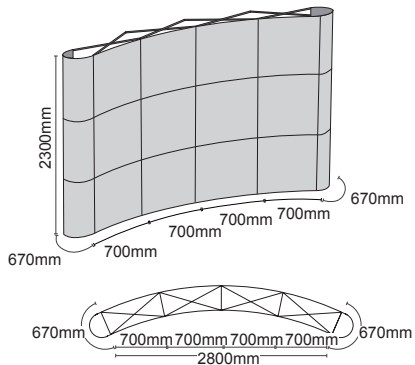

	QTY	N.W(kg)	G.W(kg)	C.B.M.	Size(mm)
Packing	1	21.7	22.1	0.12	390x340x920
10.519	670x2300mm x2				
	700x2300mm x4				



Präsentationswand als Scherengittersystem aus Aluminium, gerade oder gebogene Form. Inklusive:

- Transporttasche.
- Magnetband / Magnetschienen.
- Aufhänger.
- 2 Lichtspots.

Aluminium Flexible Pop-Up suitable for straight vertical wall system is made of a foldable tube construction. Quick and easy to assemble. The kit includes:

- Hard trolley carry bag.
- Magnetic strip roll.
- Hangers / Magnetic bars.
- 2 Spotlights.

Mur promotionnel droit ou courbé en aluminium. Inclus:

- Valise rigide.
- Rouleau de bande magnétique.
- Bandes de suspension / barres magnétiques.
- 2 foyers d'éclairage.

Painel promocional recto ou curvo para impressão. Estrutura em alumínio. Conteúdo:

- Mala rígida.
- Rolo de íman.
- Tiras de suspensão / Barras Magnéticas.
- 2 Focos de Iluminação.

Muro promocional recto o curvo para gráfica. Estructura en aluminio. Contenido:

- Maleta rígida.
- Rollo de íman.
- Perchas / Barras Magnéticas.
- 2 Focos de iluminación.

Pop-Up Arevalo 2x3 Vertical

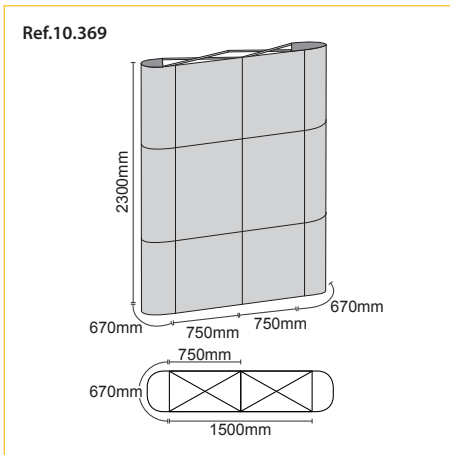

	QTY	N.W(kg)	G.W(kg)	C.B.M.	Size(mm)
Packing	1	29.4	32.6	0.32	730x430x1010
10.369	670x2300mm x2		750x2300mm x2		



Pop-Up Arevalo 3x2 Horizontal

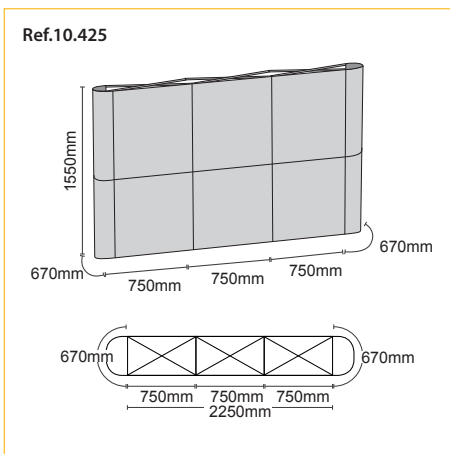

	QTY	N.W(kg)	G.W(kg)	C.B.M.	Size(mm)
Packing	1	28.8	32	0.32	720x430x1010
10.425	670x1550mm x2		750x1550mm x3		



Pop-Up Gredos 3x3 Curved

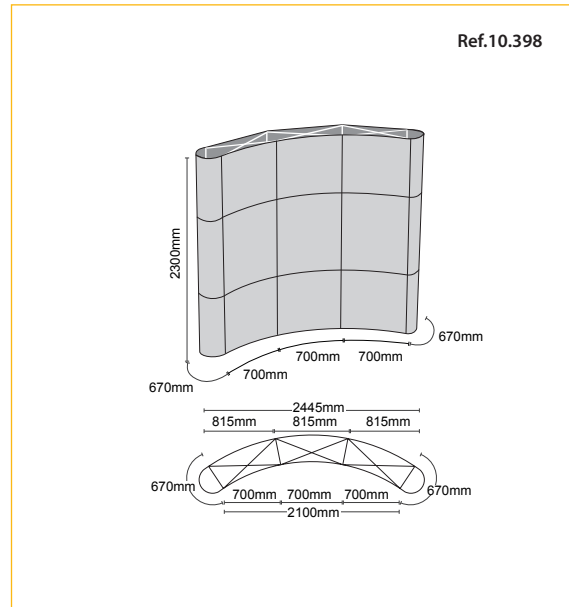
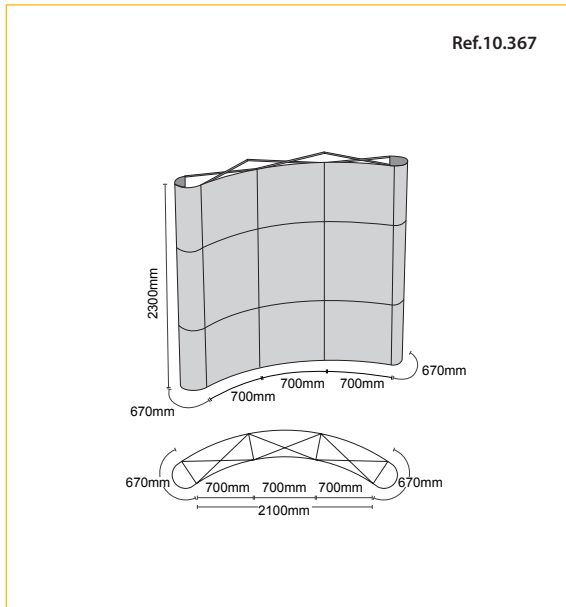

	QTY	N.W(kg)	G.W(kg)	C.B.M.	Size(mm)
Packing	1	32.25	35.45	0.32	730x430x1010
10.367		670x2300mm x2			700x2300mm x3



	QTY	N.W(kg)	G.W(kg)	C.B.M.	Size(mm)
Packing	1	34.75	37.95	0.32	730x430x1010
10.398		670x2300mm x2			700x2300mm x3
		815x2300mm x3			



POP-UP

1

Pop-Up Gredos 3x3 Straight

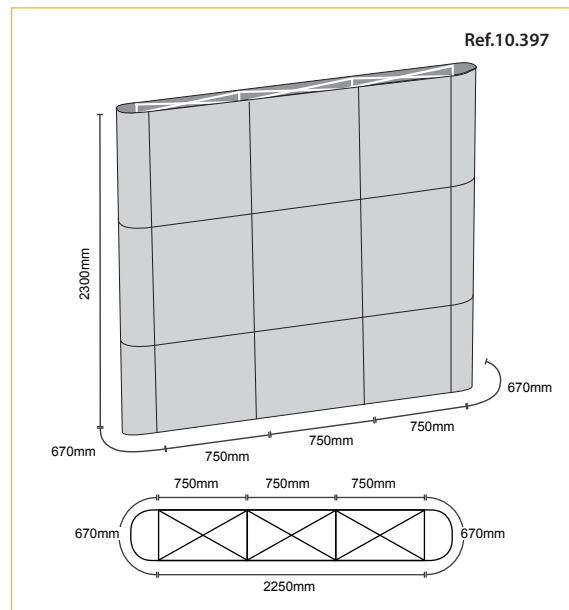
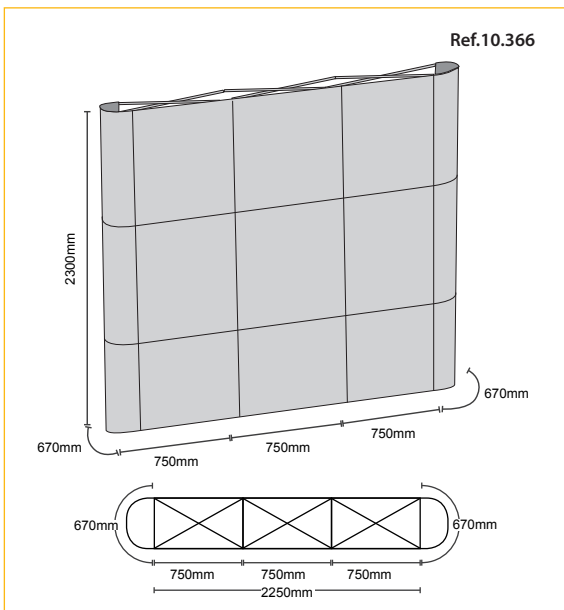

	QTY	N.W(kg)	G.W(kg)	C.B.M.	Size(mm)
Packing	1	32.25	35.45	0.32	730x430x1010
10.366	670x2300mm x2				
	750x2300mm x3				



	QTY	N.W(kg)	G.W(kg)	C.B.M.	Size(mm)
Packing	1	34.75	37.95	0.32	730x430x1010
10.397	670x2300mm x2				
	750x2300mm x6				



Pop-Up Madrigal 4x3 Curved

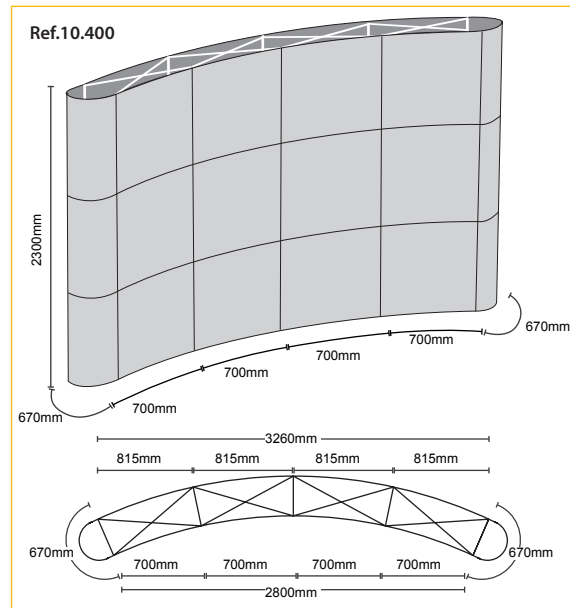
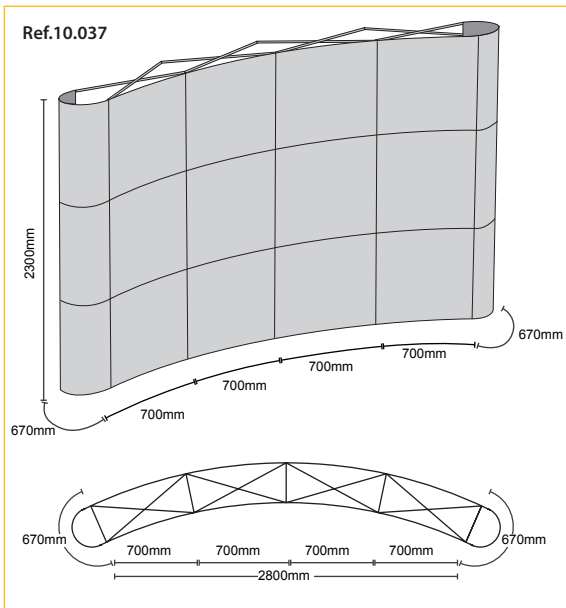

	QTY	N.W(kg)	G.W(kg)	C.B.M.	Size(mm)
Packing	1	36.3	39.5	0.3	710x430x1000
10.037		670x2300mm x2			700x2300mm x4



	QTY	N.W(kg)	G.W(kg)	C.B.M.	Size(mm)
Packing	1	44.5	47.7	0.3	710x430x1000
10.400		670x2300mm x2			700x2300mm x4 815x2300mm x4



1

Pop-Up Madrigal 4x3 Straight

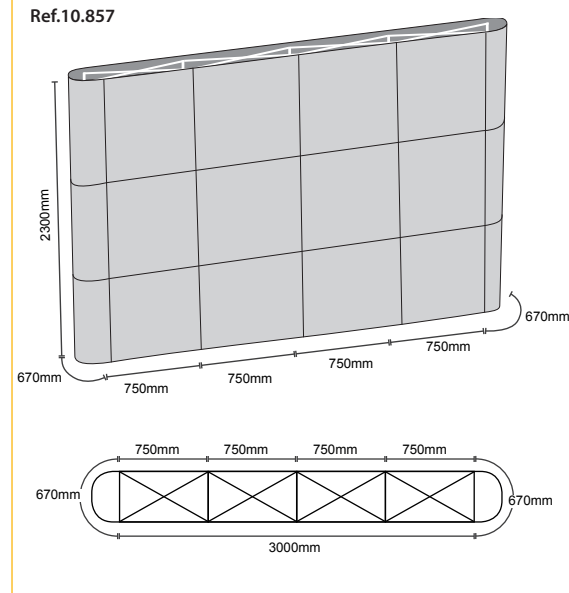
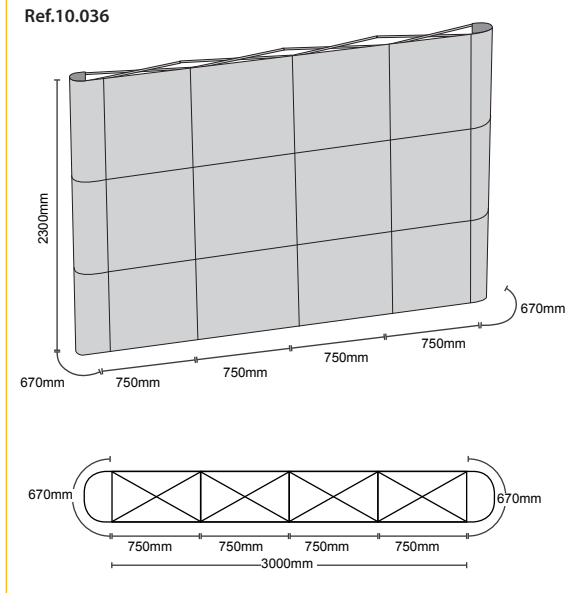

	QTY	N.W(kg)	G.W(kg)	C.B.M.	Size(mm)
Packing	1	36.3	39.5	0.3	710x430x1000
10.036	670x2300mm x2				
	750x2300mm x4				



	QTY	N.W(kg)	G.W(kg)	C.B.M.	Size(mm)
Packing	1	44.5	47.7	0.30	730x430x1000
10.857	670x2300mm x2				
	750x2300mm x8				



Pop-Up Nazare 5x3

Präsentationswand als Scherengittersystem aus Aluminium, gerade oder gebogene Form. Inklusive:

- Transporttasche.
- Magnetband / Magnetschienen.
- Aufhänger.
- Retira Füße.
- 2 Lichtspots.

Flexible Pop-Up suitable for curved or straight wall system is made of a foldable tube construction. The framework is made of aluminium.

The kit includes:

- Hard trolley carry bag.
- Magnetic strip roll.
- Hangers / Magnetic bars.
- 2 Spotlights.

Mur promotionnel droit ou courbé en aluminium.

Inclus:

- Valise rigide.
- Rouleau de bande magnétique.
- Bandes de suspension / barres magnétiques.
- 2 foyers d'éclairage.

Painel promocional recto ou curvo para impressão. Estrutura em alumínio.

Conteúdo:

- Mala rígida.
- Rolo de ímã.
- Tiras de suspensão / Barras Magnéticas.
- 2 Focos de Iluminação.

Muros promocionales rectos o curvos para gráficas. Estructura en aluminio.

Contenido:

- Maleta rígida.
- Rollo de Imán.
- Perchas / Barras Magnéticas.
- 2 Focos de Iluminación.

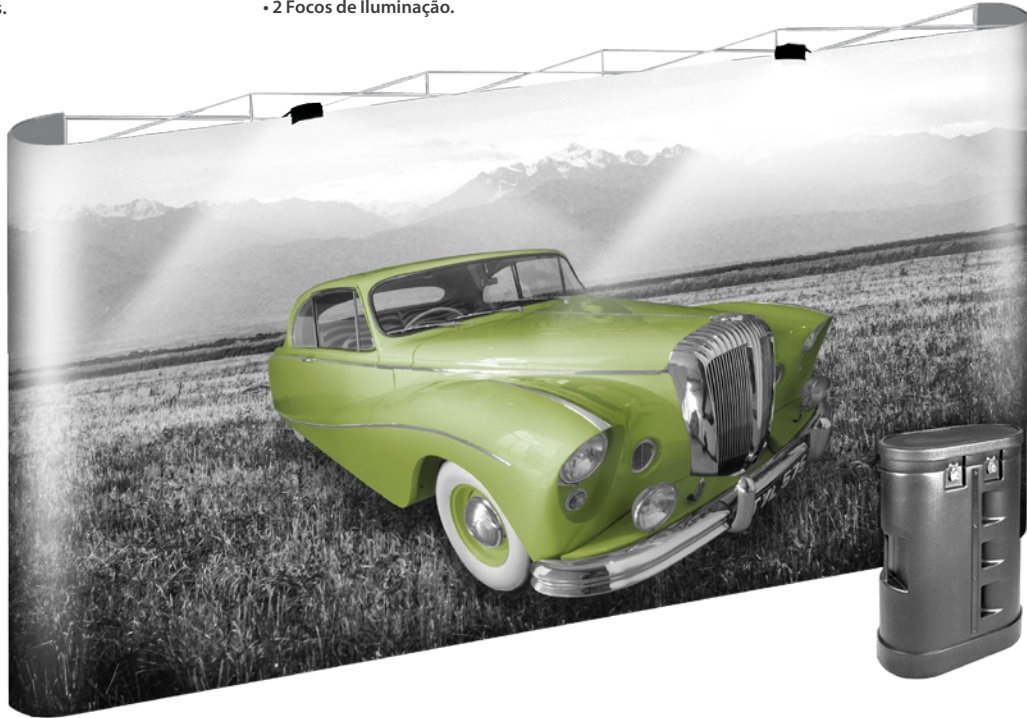

Ref.10.236

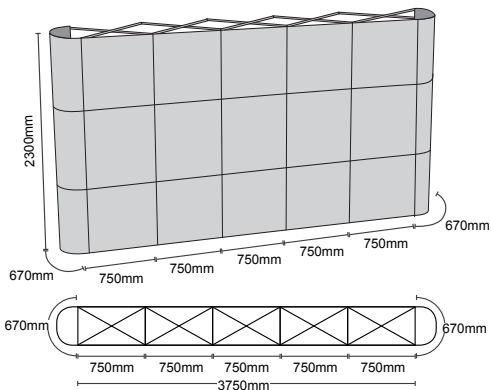

Ref.10.237

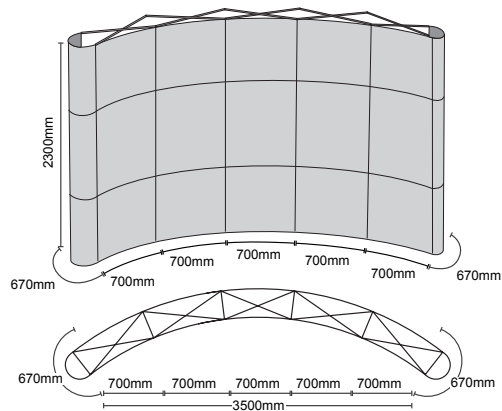

	QTY	N.W(kg)	G.W(kg)	C.B.M.	Size(mm)
Packing	1	40.1	43.3	0.32	730x430x1010
10.236		670x2300mm x2	750x2300mm x5		



	QTY	N.W(kg)	G.W(kg)	C.B.M.	Size(mm)
Packing	1	40.1	43.3	0.32	730x430x1010
10.237		670x2300mm x2	700x2300mm x5		



1

Pop-Up Teide 8x3 "S"

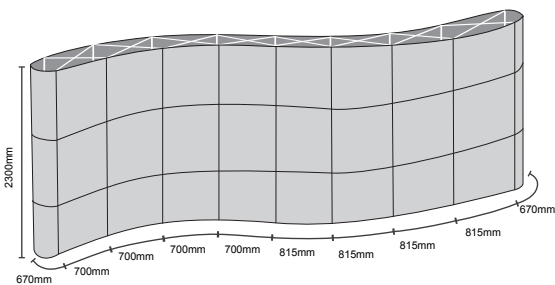
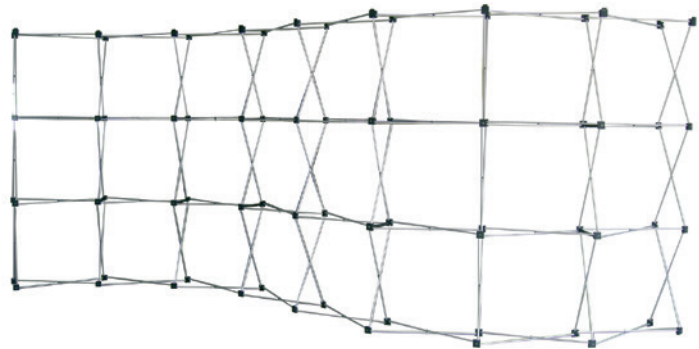

	QTY	N.W(kg)	G.W(kg)	C.B.M.	Size(mm)
Packing	2	35.6	36.6	0.31	730x430x1010
		30	31	0.31	730x430x1010
10.234	670x2300mm x2				
	700x2300mm x8				
	815x2300mm x8				



Hard-Case Trolley Maqueda

Hartschalenkoffer Typ Trolley aus schwarzem PVC, Metallverschlüsse, Gummirollen und Griffe. Koffer kann mit Grafik etikettiert und als Bestelltisch am Verkaufspunkt genutzt werden. Grafikgröße: 1810x795mm.

Hard-Case Trolley made of black PVC with rubber wheels and handle. Metal clasps. It can be used as an occasional table or complementing a stand point of sale. It can be labeled with graphic. Graphic area: 1810x795mm.

Valise de transport type Trolley Hard Case, fabriquée en PVC noir, avec roue en caoutchouc et avec poignée. Fermoirs métalliques. Peut-être utilisée comme table auxiliaire complétant un stand ou un point de vente. Un visuel peut être mis autour de la valise. Format du visuel : 1810x795mm.

Mala rígida com rodas que permite uma arrumação e transporte fácil. Área de impressão: 1810x795mm.

Carrito de transporte tipo Trolley Hard-Case, fabricado en PVC negro, con ruedas de goma y asa. Cierres metálicos. Puede usarse como mesa auxiliar complementando un stand o punto de venta. Puede rotularse con gráfica. Área gráfica: 1810x795mm.



	QTY	N.W(kg)	G.W(kg)	C.B.M.	Size(mm)
Packing	1	13	15.2	0.3	710x420x1000
10.058	700x400x960mm				

Hard-Case Trolley Noves

Hartschalenkoffer Typ Trolley aus schwarzem PVC, Metallverschlüsse, Gummirollen und Griffe. Koffer kann mit Grafik etikettiert und als Bestelltisch am Verkaufspunkt genutzt werden. Grafikgröße: 1450x745mm.

Hard-Case Trolley made of black PVC with rubber wheels and handle. Metal clasps. It can be used as an occasional table or complementing a stand point of sale. It can be labeled with graphic. Graphic area: 1450x745mm.

Valise de transport type Trolley Hard Case, fabriqué en PVC noir, avec roue en caoutchouc et anse. Fermoirs métalliques. Peut être utilisé comme table auxiliaire complétant un stand ou un point de vente. Taille graphique: 1450x745mm.

Mala rígida com rodas de tamanho médio que permite uma arrumação e transporte fácil. Área de impressão: 1450x745mm.

Carrito de transporte tipo Trolley Hard-Case, fabricado en PVC negro, con ruedas de goma y asa. Cierres metálicos. Puede usarse como mesa auxiliar complementando un stand o punto de venta. Área gráfica: 1450x745mm.



	QTY	N.W(kg)	G.W(kg)	C.B.M.	Size(mm)
Packing	1	7	9.1	0.18	410x430x1000
10.059	400x380x960mm				

Soft-Case Trolley Escalona

Softschalenkoffer Typ Trolley aus schwarzem Nylon mit Reißverschluss, zwei Tragriemen und ein ausziehbarer Griff.

Soft-Case Trolley made of black nylon fabric, with wheels and two handles type straps and an extendable handle. Closures with zippers.

Valise de type Trolley Soft Case, fabriquée en toile de nylon noire, avec roues et deux anses. Fermée par une fermeture à glissière.

Mala de transporte fabricada em nylon de cor preta com rodas. Permite uma arrumação e transporte fácil.

Carrito de transporte tipo Trolley SoftCase, fabricado en tela de nylon negro, con ruedas y dos asas tipo correas y un asa extensible. Cierres mediante cremalleras.

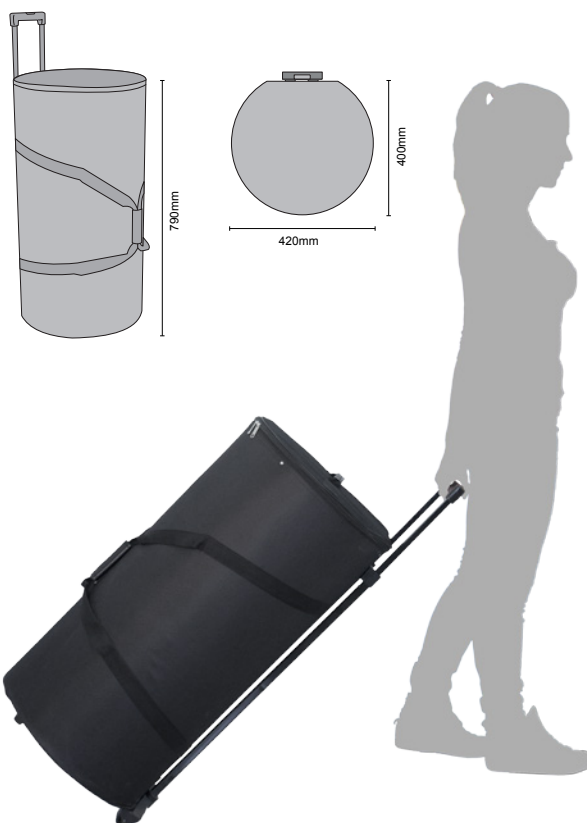

	QTY	N.W(kg)	G.W(kg)	C.B.M.	Size(mm)
Packing	1	15	18.6	0.12	680x170x1030
10.060					

1

Soft-Case Trolley

Softschalenkoffer mit Klettband.

Soft Trolley Case.

Valise de type Trolley Soft Case, fabriqué en toile.

Mala de transporte.

Carrito de transporte tipo Trolley SoftCase, fabricado en tela.

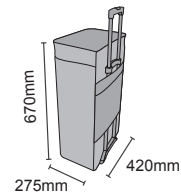
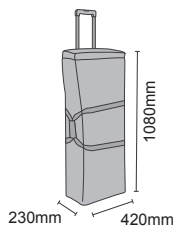

	QTY	N.W(kg)	G.W(kg)	C.B.M.	Size(mm)
Packing	1	3.75	5.70	0.13	445x265x1160

13.456

*Werbe Zähler nicht enthalten / Promotion Counters not included / Présentoir non inclus / Balcão não incluídos / Mostradores no incluídos.

	QTY	N.W(kg)	G.W(kg)	C.B.M.	Size(mm)
Packing	1	4.15	5.50	0.12	440x340x820

13.457

*Werbe Zähler nicht enthalten / Promotion Counters not included / Présentoir non inclus / Balcão não incluídos / Mostradores no incluídos.

Oxford Bag for Spotlight

Nylon-Tasche für Roll-Up Spotlights.

Nylon Bag for Roll Up Spotlights.

Housse en nylon pour spotlights de Roll Up.

Mala em nylon para focos de Roll up.

Bolsa de Nylon para focos de Roll Up.



	QTY	N.W(kg)	G.W(kg)	C.B.M.	Size(mm)
Packing	1	0.10	0.20	0.002	190x30x370

13.454

*Spotlights nicht im Lieferumfang inbegriffen / Spotlights not included / Spotlights non inclus / Focos não incluídos / Focos no incluídos.

Nylon-Tasche für Pop-Up Spotlights.

Nylon Bag for Pop-Up Spotlights.

Housse en nylon pour spotlights de Pop-Up.

Mala em nylon para focos de Pop-Up.

Bolsa de Nylon para focos de Pop-Up.

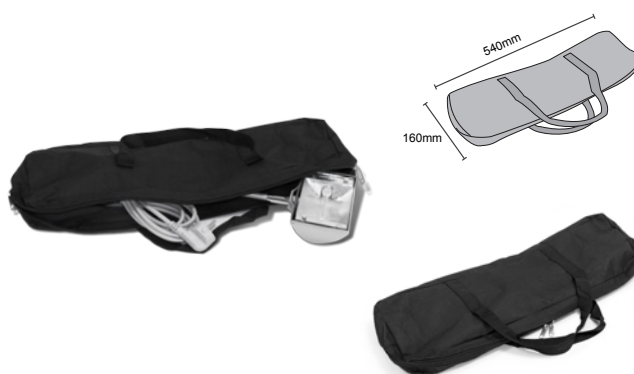

	QTY	N.W(kg)	G.W(kg)	C.B.M.	Size(mm)
Packing	1	0.15	0.20	0.002	160x30x540

13.455

*Spotlights nicht im Lieferumfang inbegriffen / Spotlights not included / Spotlights non inclus / Focos não incluídos / Focos no incluídos.

Single Oxford Bag

- Nylon- Tasche mit Reißverschluss für Roll Up.
- Single Oxford Bag with zip for Roll Up.
- Housse pour Roll Up Simple avec fermeture à glissière.
- Saco de transporte com fecho para Roll Up.
- Bolsa para Roll Up Simple con cremallera.

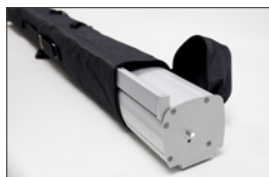

	QTY	N.W(kg)	G.W(kg)	C.B.M.	Size(mm)
Packing	1	0.12	0.22	0.003	120x30x980
13.461	For Roll Up 850mm				

	QTY	N.W(kg)	G.W(kg)	C.B.M.	Size(mm)
Packing	1	0.15	0.25	0.003	120x30x1030
13.462	For Roll Up 1000mm				

* Roll Up nicht im Lieferumfang inbegriffen / Roll Up not included / Roll Up non inclus / Roll Up não incluídos / Roll Up no incluidos.

Double Padded Bag

- Doppelpolstertasche mit Reißverschluss für Roll Up.
- Double Padded Bag with zip for Roll Up.
- Housse matelassée pour Roll Up avec fermeture à glissière.
- Saco de transporte almofadado com fecho para Roll Up.
- Bolsa acolchada para Roll Up con cremallera.

	QTY	N.W(kg)	G.W(kg)	C.B.M.	Size(mm)
Packing	1	0.40	0.60	0.004	120x40x980
13.463	For Roll Up 850mm				

	QTY	N.W(kg)	G.W(kg)	C.B.M.	Size(mm)
Packing	1	0.50	0.70	0.004	120x40x1030
13.464	For Roll Up 1000mm				

* Roll Up nicht im Lieferumfang inbegriffen / Roll Up not included / Roll Up non inclus / Roll Up não incluídos / Roll Up no incluidos.

Double Padded Zipped Bag

- Doppelpolstertasche mit seitlichem Reißverschluss für Roll Up.
- Double Padded with side zip Bag for Roll Up.
- Housse matelassée pour Roll Up avec fermeture à glissière latérale.
- Saco de transporte almofadado com fecho lateral para Roll Up.
- Bolsa acolchada para Roll Up con cremallera lateral.



	QTY	N.W(kg)	G.W(kg)	C.B.M.	Size(mm)
Packing	1	0.40	0.60	0.004	120x40x980
13.459	For Roll Up 850mm				

	QTY	N.W(kg)	G.W(kg)	C.B.M.	Size(mm)
Packing	1	0.50	0.70	0.004	120x40x1030
13.460	For Roll Up 1000mm				

* Roll Up nicht im Lieferumfang inbegriffen / Roll Up not included / Roll Up non inclus / Roll Up não incluídos / Roll Up no incluidos.

Eva Case

- Luxus-Tasche mit seitlichem Reißverschluss für Roll-Up.
- Luxury bag with side zip for Roll Up.
- Housse «Luxe» pour Roll Up avec fermeture à glissière latérale.
- Saco de transporte de alta qualidade com fecho lateral para Roll Up.
- Bolsa "Luxe" para Roll Up con cremallera lateral.



	QTY	N.W(kg)	G.W(kg)	C.B.M.	Size(mm)
Packing	1	1.05	1.45	0.016	130x130x950
13.472	For Roll Up 850mm				

* Roll Up nicht im Lieferumfang inbegriffen / Roll Up not included / Roll Up non inclus / Roll Up não incluídos / Roll Up no incluidos.

ACCESSORIES

1

Top and Bottom Bar Graphic (3x3)

Aufhänger und Stabilisierer, Set für Grafikbahnen 3x3.

Top and bottom bar graphic for Pop-Up 3x3.

Kit de bandes pour Pop-Up 3x3.

Conjunto de tiras de suspensão para Pop-Up 3x3.

Set de Perchas/Zócalos para Pop-Up 3x3.



	QTY	N.W(kg)	G.W(kg)	C.B.M.	Size(mm)
Set	10	0.68	0.7	0.0008	55x20x750

10.714 Straight

	QTY	N.W(kg)	G.W(kg)	C.B.M.	Size(mm)
Set	10	0.7	0.72	0.0007	55x20x700

10.715 Curved / Front

	QTY	N.W(kg)	G.W(kg)	C.B.M.	Size(mm)
Set	6	0.46	0.48	0.0004	55x10x810

10.491 Curved / Back

Top and Bottom Bar Graphic (4x3)

Aufhänger und Stabilisierer, Set für Grafikbahnen 4x3.

Top and bottom bar graphic for Pop-Up 4x3.

Kit de bandes pour Pop-Up 4x3.

Conjunto de tiras de suspensão para Pop-Up 4x3.

Set de Perchas/Zócalos para Pop-Up 4x3.

	QTY	N.W(kg)	G.W(kg)	C.B.M.	Size(mm)
Set	12	0.83	0.85	0.008	55x20x750

10.716 Straight

	QTY	N.W(kg)	G.W(kg)	C.B.M.	Size(mm)
Set	12	0.78	0.8	0.0007	55x20x700

10.717 Curved / Front

	QTY	N.W(kg)	G.W(kg)	C.B.M.	Size(mm)
Set	8	0.6	0.62	0.0004	55x15x810

10.492 Curved / Back

Magnetic Bar

Magnetschiene für Pop-Up, geeignet für Modell Madrigal, Gredos, Arévalo, Laredo und Llanes.

Magnetic bar for Pop-Up. Can be used with the models Madrigal, Gredos, Arévalo, Laredo and Llanes.

Barre magnétique pour Pop-Up. Compatible avec les modèles Madrigal, Gredos, Arevalo, Laredo et Llanes.

Barra magnética compatível com os modelos Madrigal, Gredos, Arevalo, Laredo, Llanes.

Barra magnética para Pop-Up. Válida para los modelos Madrigal, Gredos, Arévalo, Laredo y Llanes.

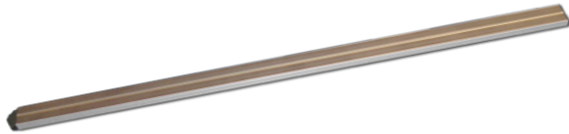

	QTY	N.W(kg)	G.W(kg)	C.B.M.	Size(mm)
Packing	1	0.2	0.22	0.0003	50x10x760

10.419 720mm

Cross for Pop-Up



	QTY	N.W(kg)	G.W(kg)	C.B.M.	Size(mm)
Packing	1	0.70	0.80	0.005	80x80x800

10.897

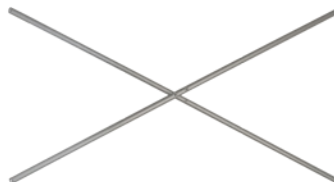

Plastic Piece For Magnetic Bar

	QTY	N.W(kg)	G.W(kg)	C.B.M.	Size(mm)
Packing	1	0.014	0.015	0.00002	50x10x50

10.858 50x50x10mm



Pop-Up Corner

	QTY	N.W(kg)	G.W(kg)	C.B.M.	Size(mm)
Packing	1	0.038	0.039	0.00007	50x30x50

10.409 50x50x20mm







Plastic Piece For Bar Graphics

	QTY	N.W(kg)	G.W(kg)	C.B.M.	Size(mm)
Packing	1	0.02	0.021	0.00006	50x20x60

10.859 60x50x10mm







PVC Pannel Pop-Up

-  PVC Paneel für Pop-Up.
-  PVC pannel for Pop-Up.
-  Panneau en PVC pour Pop-Up.
-  Paniel de PVC para Pop-Up.
-  Panel de PVC para Pop-Up.



	QTY	N.W(kg)	G.W(kg)	C.B.M.	Size(mm)
Packing	1	1.15	2.5	0.015	130x130x890
10.101	2400x880x0,4mm				



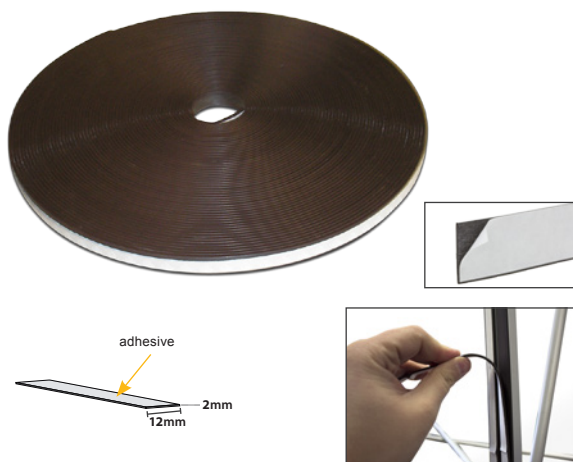

Magnetic Strip Roll 12mm

-  Magnetband 50m zur Befestigung von Pop-Up.
-  Magnetic strip roll, 50 meters length for fixing Graph Pop-Up.
-  Rouleau de bande magnétique de 50 m pour la fixation des images au Pop-Up.
-  Rolo magnético com 50 metros.
-  Rollo de imán de 50 m para fijación de gráficas de Pop-Up.



	QTY	N.W(kg)	G.W(kg)	C.B.M.	Size(mm)
Packing	1	9	9.50	0.0044	420x25x420
10.360	50m x 12mm				

Graphic Case

-  Zeichenrollen - Köcher aus PVC, ausziehbar, ideal für den Transport von Grafiken.
-  Graphic case, adjustable in height and portable, made of PVC. Ideal for transporting graphics or displays.
-  Porte-visuel, télescopique et portable, fabriqué en PVC. Idéal pour le transport d'images ou de displays.
-  Tubo para transporte de impressões ajustável em altura. PVC.
-  Porta-Gráficas extensible y portátil, realizado en PVC. Ideal para el transporte de gráficas o displays.

	QTY	N.W(kg)	G.W(kg)	C.B.M.	Size(mm)
Uni.	1	0.4	0.42	0.006	100x100x640

10.074

10.075 Ø 107mm 640-1070mm

	QTY	N.W(kg)	G.W(kg)	C.B.M.	Size(mm)
Uni.	1	0.5	0.52	0.008	100x100x780

10.076

10.077 Ø 107mm 779-1280mm

	QTY	N.W(kg)	G.W(kg)	C.B.M.	Size(mm)
Uni.	1	0.3	0.32	0.004	80x60x630

10.078

10.079 Ø 85mm 630-1070mm







1

Spotlights



Spotlight Roll Up

-  Halogenstrahler für Roll Up.
-  Spotlight for Roll Up.
-  Foyer d'éclairage pour Roll Up.
-  Foco de Iluminação para Roll Up.
-  Foco de iluminación para Roll up.



	QTY	N.W(kg)	G.W(kg)	C.B.M.	Size(mm)
Uni.	1	0.30	0.35	0.0016	125x65x200

10.525

60 W





Spotlight Roll Up

 Leistungsstarker Halogenstrahler zur Unterstützung Ihrer Werbeaussage, in Schwarz oder Aluminium matt.

 Spotlight for promotional support. Bulb type Halogen (included) and directional head, large luminous capacity. Works directly plugged in. Finished in black or matt aluminum.

 Foyer d'éclairage pour supports promotionnels. Ampoule de type Halogène (incluse) avec une tête orientable, grande capacité d'éclairage. Se branche directement sur le secteur. Finition en noir et en aluminium mat.

 Foco de iluminação ideal para Roll Up. Inclui cabo com ficha para ligação à tomada e lâmpada.

 Foco de iluminación para soporte promocional. Bombilla tipo halógena (incluida) y cabeza direccional, gran capacidad luminosa. Funciona directamente a corriente. Acabado en negro o aluminio mate.



Spotlight Roll Up

 Leistungsstarker Halogenstrahler zur Unterstützung Ihrer Werbeaussage, in Schwarz.

 Spotlight for promotional support. Bulb type Halogen (included) and directional head, large luminous capacity. Works directly plugged in. Finished in black or silver.

 Foyer d'éclairage pour supports promotionnels. Ampoule de type Halogène (incluse) avec une tête orientable, grande capacité d'éclairage. Se branche directement sur le secteur. Finition en noir et argent.

 Foco de iluminação ideal para Roll Up. Inclui cabo com ficha para ligação à tomada e lâmpada.

 Foco de iluminación para soporte promocional. Bombilla tipo halógena (incluida) y cabeza direccional, gran capacidad luminosa. Funciona directamente a corriente. Acabado en negro y plata.



	QTY	N.W(kg)	G.W(kg)	C.B.M.	Size(mm)
Uni.	1	0.30	0.35	0.002	100x70x400

10.057

13.401  50 W

10.055 

10.056  50 W

LED Spotlight Clamp Roll Up

Leistungstarker LED-Strahler zur Unterstützung Ihrer Werbeaussage.

LED light clamp for Roll Up.

Foyer d'éclairage à LED pour Roll Up.

Foco de Iluminação para Roll Up. LED.

Foco de luz para Roll Up. LED.



	QTY	N.W(kg)	G.W(kg)	C.B.M.	Size(mm)
Uni.	1	0.4	0.8	0.038	150x50x510
10.687			12 W		

Spotlight Pop-Up

Leistungstarker Halogenstrahler zur Unterstützung Ihrer Werbeaussage, in Schwarz.

Spotlight for Pop-Up promotional support. Works directly plugged in. Black finishing.

Foyer d'éclairage pour supports promotionnels Pop-Up. Se branche directement sur le secteur. Finition en noir.

Foco de iluminação ideal para Pop-Up. Inclui cabo com ficha para ligação à tomada e lâmpada.

Foco de iluminación para soporte promocional Pop-Up. Funciona directamente a corriente. Acabado en negro.



	QTY	N.W (kg)	G.W (kg)	C.B.M.	Size(mm)
Packing	1	0.65	0.7	0.038	150x50x510
10.368			150 W		

LED Spotlight Pop-Up

Leistungstarker LED-Strahler zur Unterstützung Ihrer Werbeaussage.

Led spotlight for Pop-Up promotional support. Works directly plugged in. Black finishing.

Foyer d'éclairage à LED pour Pop-Up.

Foco com LED e pinça para Pop-Up.

Foco de iluminación LED para soporte promocional Pop-Up. Funciona directamente a corriente. Acabado en negro.





	QTY	N.W (kg)	G.W (kg)	C.B.M.	Size(mm)
Packing	1	0.45	0.85	0.038	150x50x510
10.688			12 W		

TexFix

 Präsentationsrahmen aus Aluminiumprofilen für Textildrucke. Profile in Standardmaße oder laufender Meter. Set enthält: Aluminiumprofil, Verbindungswinkel, Silikonstreifen. Schnelle und einfache Montage. Auf dem Textildruck sollte ein umlaufender Silikonstreifen genäht sein, damit lässt sich das Motiv leicht in die Profile einschieben und spannen.

 Aluminium Profile solutions for textile digital printing. Different profiles are available in standard sizes or in linear meters. Easy and quick to assemble. The fabric should be sewn into a "silicon strip" across its profile, which is then inserted in the insertion of the grid remaining tight and perfectly framed for its presentation.

 Profil spécial en aluminium pour textile et de montage facile. Les profils sont fournis en formats standard ou au mètre linéaire. Le textile se coud sur une « bande de silicone », qui va s'introduire dans la rainure du profil ce qui permet un visuel parfaitement présenté, tendu et encadré.

 Perfil especial em alumínio para impressão digital em têxtil. Montagem fácil e rápida. Os perfis são fornecidos em medidas estandarizadas ou por metro linear, para adequar ao espaço requerido. O tecido deve ser cosido a uma tira de silicone, que posteriormente será introduzida na ranhura do perfil de modo a ficar tenso e perfeitamente colocado.

 Soluciones de perfilera especial para tejidos realizados en aluminio listos para su montaje. Los perfiles se suministran en medidas estándar o por metros lineales para adecuar al espacio requerido. El tejido debe ser cosido a una "tira de silicona" en todo su perfil, que posteriormente se introduce en la inserción de la perfilera quedando de esta manera tensada y perfectamente enmarcada y presentada.



Setup

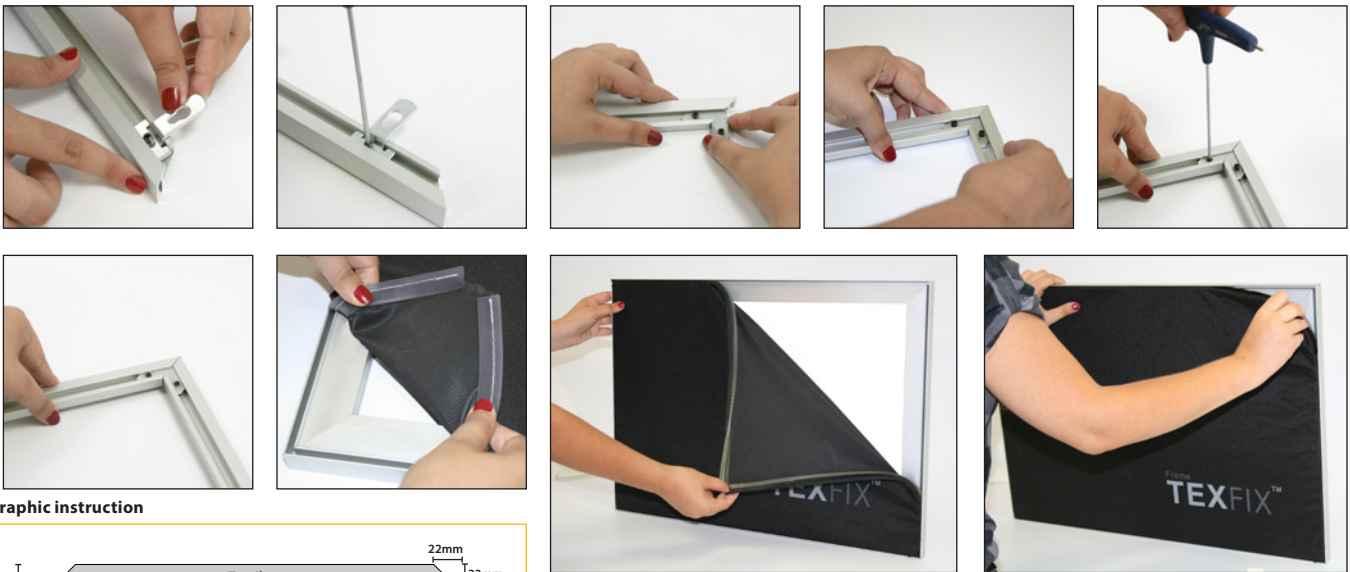

Graphic instruction

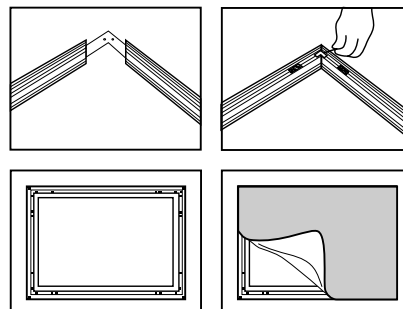
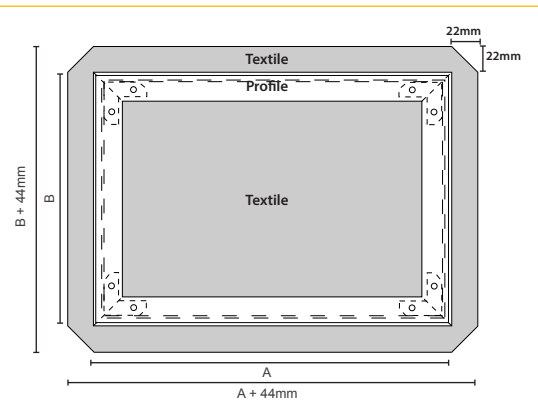

TexFix Frame 16mm

Einfache Aluminium-Profilrahmen zum einspannen von Textil-Digitaldrucken. Ideal zur Befestigung oder zum Aufhängen an die Wand. Lieferumfang: 4 Profile, 4 Eckverbinder und 1 Inbusschlüssel (Optional Aufhänger).

Simple aluminium frame profile for textile digital printing. Ideal for hanging or fixing on the wall. The item includes: 4 Profiles, 4 corners and 1 Allen key type. (Optional hangers).

Profil simple en aluminium pour des impressions digitales en textile. Idéal pour suspendre au plafond ou fixer au mur. 4 profils, 4 équerres et 1 clef Allen inclus. Crochets vendus séparément.

Perfil simples de alumínio para impressão digital. Ideal para pendurar ou fixar na parede. Inclui 4 perfis, 4 esquinas e 1 chave tipo Allen (suspensão opcional).

Perfil simple para la elaboración de marcos textiles mediante impresión digital. Incluye 4 perfiles, 4 esquineros y 1 llave tipo Allen (colgadores opcional).

Includes:

- x4
- x4
- x1
Ø2.5

13.132	A4		
13.133	A3		
13.134	A2		
13.135	A1		
13.136	500x700mm		
13.137	700x1000mm		
13.138	500x1000mm		



Befestigung an der Wand mit Schrauben in den genannten Größen.

Fixing on the wall with screws in these sizes.

Fixer avec des vises pour toutes les tailles.

Fixar à parede seguindo as medidas indicadas.

Fijar con tornillos a la pared en estas medidas.

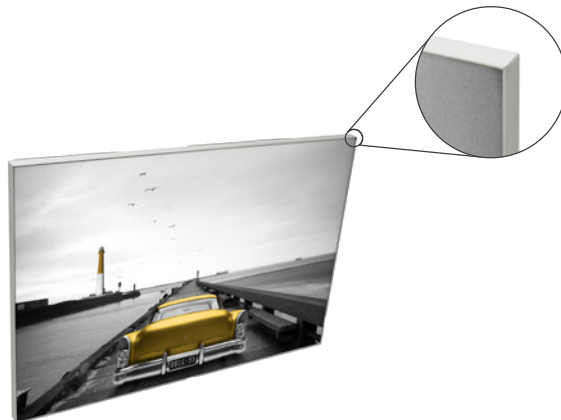
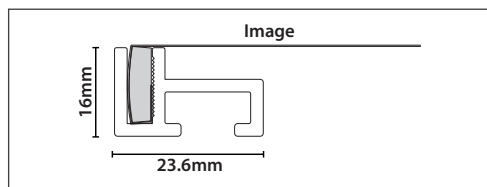

Aluminium Profile by Meters

Sonderprofile: Lieferumfang 4 Stück auf 3m Länge. Insgesamt 12m.

The non-standard profiles are supplied in packs of 4 barras and each has 3 linear meters long. Total 12m.

Profil vendu au mètre linéaire et fourni en pack de 4 barres de 3 mètres linéaires. Total 12m.

Perfil de alumínio vendido ao metro linear. Inclui 4 perfis de 3 metros. Total: 12 m.

La perfilería no estándar se suministra en paquetes de 4 barras de 3m/lineales. Total 12m.

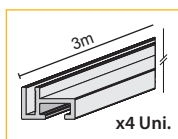

Eck-Verbinder.

Corner connector.

Connexion d'angle.

Esquina.

Esquinero.



13.139 4 uni. x 3m/l = 12m/l

13.171 x20

TexFix Wall Frame 27.5mm

Aluminium – Spannrahmenprofil für Textil - Digitaldruck. Sehr gut geeignet für freistehende Wände.

Simple aluminum frame profile for textile digital printing. Special for free spaces on walls.

Profil simple en aluminium pour des impressions digitales en textile. Idéal pour combler des espaces vides.

Perfil simples de alumínio para a elaboração de molduras que permitem a colocação de impressões têxteis digitais. Ideal para cavidades nas paredes.

Perfil simple de aluminio para colocación en huecos y espacios libres en muros. Impresión sobre textil.



Sonderprofile: Lieferumfang 4 Stück auf 3m Länge. Insgesamt 12m.

Aluminium profile in linear meters includes 4 units with 3 m lengths. Total 12 m.

Profil en aluminium disponible au mètre linéaire. Inclus 4 barres de 3 mètres linéaires. Total 12 m.

Perfil de alumínio vendido ao metro linear. Inclui 4 perfis de 3 metros. Total: 12 m.

Perfil de aluminio en metros lineales. Incluye 4 unidades con 3m de longitud cada una. Total 12m.

	QTY	N.W(kg)	G.W(kg)	C.B.M.	Size(mm)
Packing	4	2.45	2.85	0.0147	75x65x3015

13.157 4 uni. x 3m/l = 12m/l



Eck-Verbinder.

Corner connector.

Connexion d'angle.

Esquina.

Esquinero.

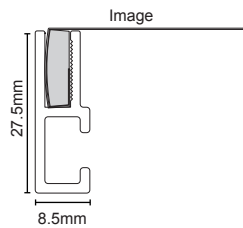

13.243

x20

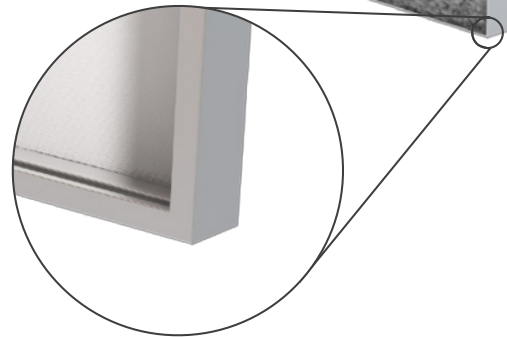

TexFix Frame 41.5x16mm Double-Sided

DE Doppelseitige Aluminium-Profilrahmen zum einspannen von Textil-Digitaldrucken. Kombination mit den Füßen sorgt für sicheren Halt Aluminium. Standardgröße. Lieferumfang: 4 Profile, 4 Eckverbinder und 1 Inbusschlüssel.

UK Double-sided aluminum frame profile for textile digital printing. Used with feet to be placed on a floor. Standard sizes. The item includes: 4 Profiles, 4 corners and 1 Allen key type.

FR Profil double en aluminium pour des impressions digitales sur textile. Avec socle pour une utilisation au sol. Tailles préconisées. 4 profils, 4 équerres et 1 clef Allen inclus.

PT Perfil dupla face em alumínio para a elaboração de molduras que permitem a colocação de impressões têxteis digitais. Usado em conjunto com pés que vão permitir a sua colocação no solo. Tamanhos estandardizados. Inclui 4 perfis, 4 esquinhas e 1 chave tipo Allen.

ES Perfil doble para la elaboración de marcos de aluminio mediante impresión digital sobre textil. Medidas estandar. Incluye: 4 perfiles, 4 esquineros y 1 llave tipo Allen.

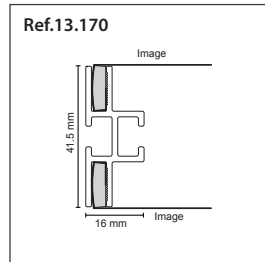

Includes: x4 x4 x1 Ø2.5

13.158	A4	
13.159	A3	
13.160	A2	
13.161	A1	

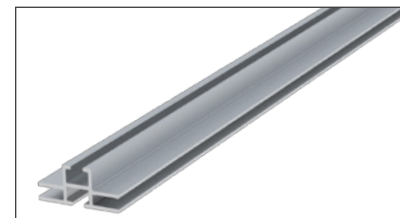

Aluminium Profile by Meters

DE Sonderprofile: Lieferumfang 4 Stück auf 3m Länge. Insgesamt 12m.

UK Aluminium profile in linear meters includes 4 units and each has 3 linear meters long. Total 12 m.

FR Profil vendu au mètre linéaire et fourni en pack de 4 barres de 3 mètres linéaires. Total 12 m. Connexion d'angle.

PT Perfil de alumínio vendido ao metro linear. Inclui 4 perfis de 3 metros. Total: 12 m.

ES Perfil de aluminio en metro lineales, incluye 4 unidades de 3m de longitud. Total 12m.

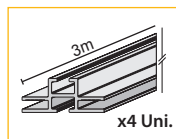

DE Eck-Verbinder.

UK Corner connector.

FR Connexion d'angle.

PT Esquina.

ES Esquinero.



	QTY	N.W(kg)	G.W(kg)	C.B.M.	Size(mm)
Packing	4	4.66	5.11	0.0147	75x65x3015

13.170	4 uni. x 3m/l = 12m/l	
--------	-----------------------	--

13.243	x20	
--------	-----	--

1 TexFix Frame 41.3x38.1mm Double-Sided

Doppelseitige Aluminium-Profilrahmen zum einspannen von Textil-Digitaldrucken. Kombination mit den Füßen sorgt für sicheren Halt Aluminium. Standardgröße. Lieferumfang: 4 Profile, 4 Eckverbinder und 1 Inbusschlüssel. Füße sind nicht enthalten.

Double-sided aluminum frame profile for textile digital printing. Used with feet to be placed on a floor. Standard sizes. The item includes: 4 Profiles, 4 corners and 1 Allen key type. Feet not included.

Profil double en aluminium pour des impressions digitales en textile. Avec socle pour une utilisation au sol. Tailles préconisées. 4 profils, 4 équerres et 1 clef Allen inclus. Socles non inclus.

Perfil dupla face em alumínio para a elaboração de molduras que permitem a colocação de impressões têxteis digitais. Usado em conjunto com pés que vão permitir a sua colocação no solo. Tamanhos estandardizados. Inclui 4 perfis, 4 esquinas e 1 chave tipo Allen. Pés não incluídos.

Perfil doble para la elaboración de marcos de aluminio mediante impresión digital sobre textil. Medidas estandar. Incluye: 4 perfiles, 4 esquineros y 1 llave tipo Allen. Patas no incluidas.

Ref.13.058

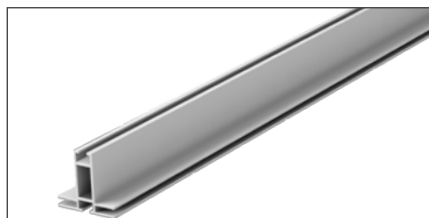
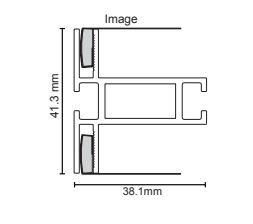

Includes:



13.163	500x700mm	
13.166	500x1000mm	
13.164	700x1000mm	
13.162	A0	
13.167	1000x1000mm	
13.165	1000x1400mm	
13.168	1000x1500mm	
13.282	700x2000mm	
13.169	1000x2000mm	



Aluminium Profile by Meters

Sonderprofile: Lieferumfang 4 Stück auf 3m Länge. Insgesamt 12m.

The non-standard profiles are supplied in packs of 4 barras and each has 3 linear meters long. Total 12m.

Profil vendu au mètre linéaire et fournis en pack de 4 barres de 3 mètres linéaires. Total 12m.

Perfil de alumínio vendido ao metro linear. Inclui 4 perfis de 3 metros. Total: 12m.

Perfil de aluminio en metro lineales, incluye 4 unidades de 3m de longitud. Total 12m.

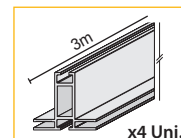

13.058 4 uni. x 3m/l = 12m/l



TexFix Frame 100x20.5mm Double-Sided

Doppelseitige Aluminium-Profilrahmen zum einspannen von Textil-Digitaldrucken. Kombination mit den Füßen sorgt für sicheren Halt Aluminium. Standardgröße.

Double-sided aluminum frame profile for textile digital printing. Used with feet to be placed on a floor. Standard sizes. Base feet not included. Accessories not included.

Profil double en aluminium pour des impressions digitales sur textile. Avec socle pour une utilisation au sol. Tailles préconisées. Accessoires non inclus. Socle non inclus.

Perfil dupla face em alumínio para a elaboração de molduras que permitem a colocação de impressões têxteis digitais. Usado em conjunto com pés que vão permitir a sua colocação no solo. Tamanhos estandarizados. Pés e acessórios não incluídos.

Perfil doble para la elaboración de marcos de aluminio mediante impresión digital sobre textil. Medidas estandar. Patas no incluidas.

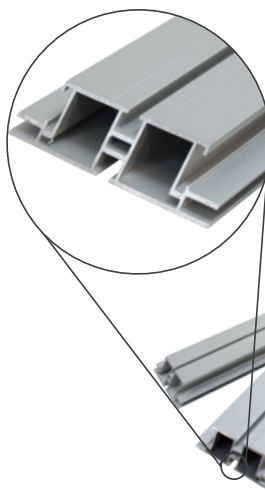

x2

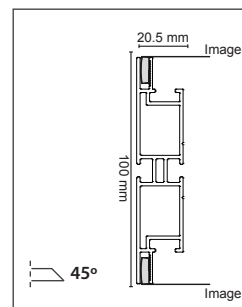

13.300	500mm	x2		
13.301	1000mm	x2		
13.302	1500mm	x2		
13.303	2000mm	x2		
13.304	2500mm	x2		
13.305	3000mm	x2		

* Die Enden auf Gehrung geschnitten 45° / The ends are mitred
Couper la terminaison de la barre en biais à 45° / Corte em esquadria de 45° / Cortado al inglete.

Central Connector Profile

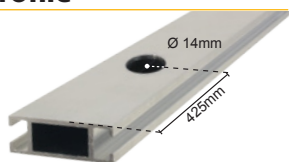

Sonderprofile: Lieferumfang 4 Stück auf 3m Länge. Insgesamt 12 m.

Aluminium profile in linear meters includes 4 units with 3 mts lengths. Total 12 m.

Profils vendus au mètre linéaire et fournis en pack de 4 barres de 3 m linéaires. Total 12 m.

Perfil de alumínio vendido ao metro linear. Inclui 4 perfis de 3m. Total: 12 m.

Perfil de aluminio en metros lineales, incluye 4 unidades de 3 m de longitud. Total 12 m.

	QTY	N.W(kg)	G.W(kg)	C.B.M.	Size(mm)
Packing	4	5.05	5.40	0.0147	75x65x3020
13.246	4 uni. x 3m/l = 12m/l				

Corner connection

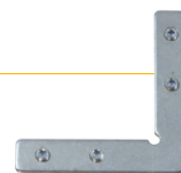

	QTY	N.W(kg)	G.W(kg)	C.B.M.	Size(mm)
Packing	20	0.66	0.85	0.0005	75x75x90

13.333 x20

Lock

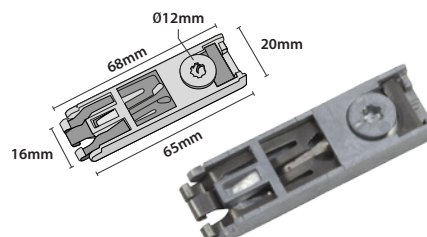

13.244

TEXFIX LIGHT

1



TexFix Frame 100x20.5mm Double-Sided With Light

Doppelseitige Aluminium-Profilrahmen zum einspannen von Textil-Digitaldrucken. Kombination mit den Füßen sorgt für sicheren Halt. Preis ist für ein komplettes Kit.

Double Aluminum Profile for light frame using digital printing textile. Used with feet to be placed on the floor. Prices for complete kit.

Profil lumineux double face en aluminium pour des impressions digitales sur textile. Avec socle pour une utilisation au sol.

Perfil duplo para a elaboração de molduras de alumínio com luz para colocação de impressões digitais em têxtil. Utilizado com bases para poder ser colocado no chão. Preço para kit completo.

Perfil doble de aluminio con luz para impresiones digitales sobre textil. Utilizado con bases para colocarlo en el suelo. Precio por kit completo.

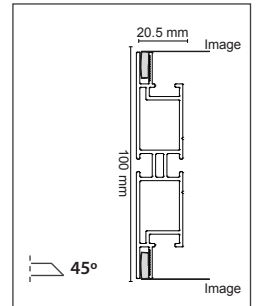
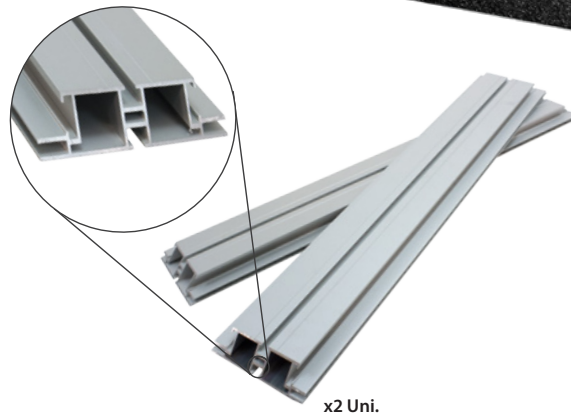
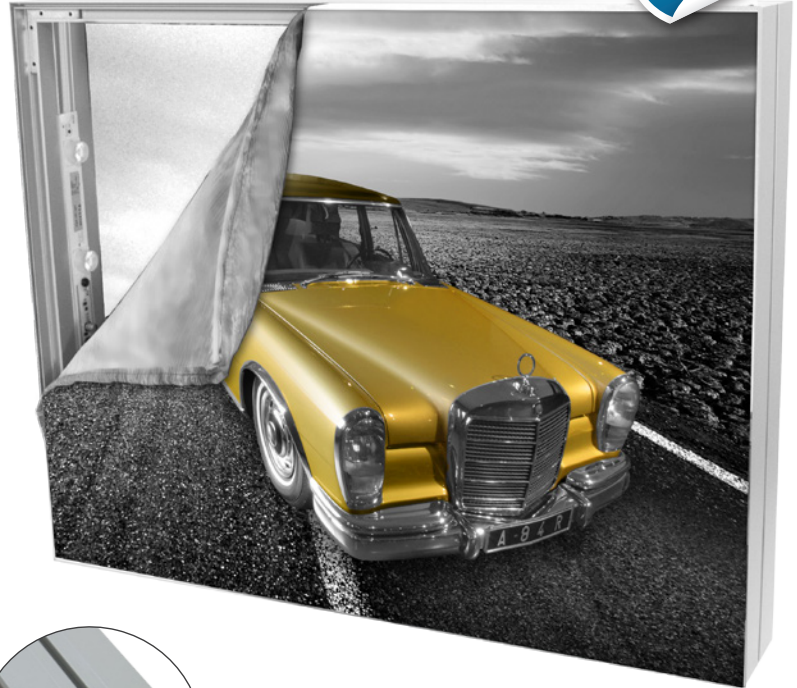

Kit includes

Profiles & Corners connections

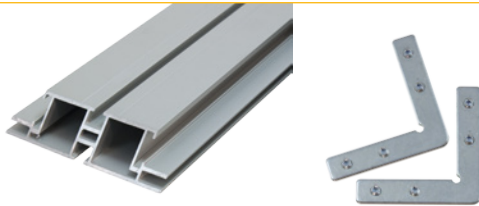

Central Connector Profile & Locks

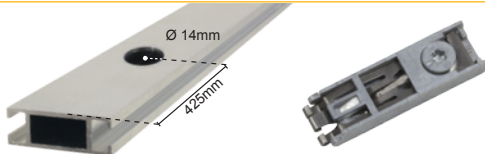

* Nur in den vorgeschriebenen Maßen enthalten/ Only included in required measures / Seulement inclus pour les dimensions requis / Incluido somente nas medidas mencionadas / Incluido sólo en medidas requeridas.



LEDs Light system

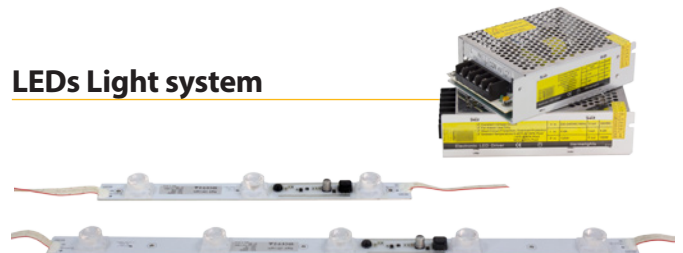

Tools & Accessories



- Electric clamp for cable.
- Cable with plug.
- Cable for internal connection.
- Easy grommet placement.
- Zinc screws.
- 2.5mm Allen wrench.
- 4mm Allen wrench for locks (In required measures).

TEXFIX LIGHT

Complete KITS - TexFix Frame 100x20.5mm Double-Sided With Light

Power Supply



LED Lens 300 mm



LED Lens 520 mm





mm	600	700	1000	1500	2000	2500	3000
600	13.308	13.309	13.310	13.311	13.312	13.313	13.314
	LED 520 x1 Uni.	LED 520 x1 Uni.	LED 520 x1 Uni.	LED 520 x2 Uni.	LED 520 x2 Uni.	LED 520 x3 Uni. LED 300 x2 Uni.	LED 520 x4 Uni. LED 300 x2 Uni.
		Use in short sides (600mm)	Use in short sides (600mm)	Use in short sides (600mm)	Use in short sides (600mm)	Use in long sides (2500mm)	Use in long sides (3000mm)
	Pw. Suppl. 60W/24V x 1 Uni.	Pw. Suppl. 60W/24V x 1 Uni.	Pw. Suppl. 60W/24V x 1 Uni.	Pw. Suppl. 60W/24V x 1 Uni.	Pw. Suppl. 60W/24V x 1 Uni.	Pw. Suppl. 60W/24V x 1 Uni.	Pw. Suppl. 100W/24V x 1 Uni.
700		13.315	13.316	13.317	13.318	13.319	13.320
		LED 520 x1 Uni.	LED 520 x1 Uni.	LED 520 x2 Uni.	LED 520 x2 Uni.	LED 520 x3 Uni. LED 300 x2 Uni.	LED 520 x4 Uni. LED 300 x2 Uni.
			Use in short sides (700mm)	Use in short sides (700mm)	Use in short sides (700mm)	Use in long sides (2500mm)	Use in long sides (3000mm)
		Pw. Suppl. 60W/24V x 1 Uni.	Pw. Suppl. 60W/24V x 1 Uni.	Pw. Suppl. 60W/24V x 1 Uni.	Pw. Suppl. 60W/24V x 1 Uni.	Pw. Suppl. 60W/24V x 1 Uni.	Pw. Suppl. 100W/24V x 1 Uni.
1000			13.321	13.322	13.323	13.324	13.325
			LED 520 x1 Uni. LED 300 x1 Uni.	LED 520 x2 Uni. LED 300 x1 Uni.	LED 520 x2 Uni. LED 300 x2 Uni.	LED 520 x3 Uni. LED 300 x2 Uni.	LED 520 x4 Uni. LED 300 x2 Uni.
			Use in a side (1000mm)	Use in a side (1500mm)	Use in short sides (1000mm)	Use in long sides (2500mm)	Use in long sides (3000mm)
			Pw. Suppl. 60W/24V x 1 Uni.	Pw. Suppl. 60W/24V x 1 Uni.	Pw. Suppl. 60W/24V x 1 Uni.	Pw. Suppl. 60W/24V x 1 Uni.	Pw. Suppl. 100W/24V x 1 Uni.
1500				13.326	13.327	13.328	13.329
				LED 520 x4 Uni. LED 300 x2 Uni.	LED 520 x4 Uni. LED 300 x2 Uni.	LED 520 x6 Uni. LED 300 x4 Uni.	LED 520 x8 Uni. LED 300 x4 Uni.
				Use in the two opposite sides (1500mm)	Use in short sides (1500mm)	Use in long sides (2500mm)	Use in long sides (3000mm)
				Pw. Suppl. 100W/24V x 1 Uni.	Pw. Suppl. 100W/24V x 1 Uni.	Pw. Suppl. 150W/24V x 1 Uni.	Pw. Suppl. 150W/24V x 1 Uni.
2000					13.330	13.331	13.332
					LED 520 x6 Uni. LED 300 x2 Uni.	LED 520 x6 Uni. LED 300 x4 Uni.	LED 520 x8 Uni. LED 300 x4 Uni.
					Use in the two opposite sides (2000mm)	Use in long sides (2500mm)	Use in long sides (3000mm)
					Pw. Suppl. 100W/24V x 1 Uni.	Pw. Suppl. 150W/24V x 1 Uni.	Pw. Suppl. 150W/24V x 1 Uni.

TEXFIX LIGHT

1

TexFix Light Ultra Slim

 Schmale Einzelprofilrahmen aus Aluminium mit LEDs. Einfach und schnell zu montieren.









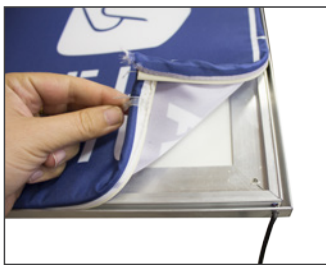
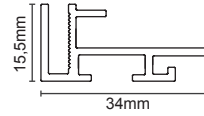





 Single aluminum frame profile with LEDs. Easy and quick to assemble.

 Profil, simple face, lumineux en aluminium. Facile à assembler.

 Perfil simple para moldura com luz. De fácil e rápida montagem. Alumínio.

 Perfil simple de aluminio con LEDs. Fácil y rápido de montar.



13.180	A4		
13.179	A3		
13.178	A2		
13.177	A1		
13.176	A0		
13.306	500x700mm		
13.307	700x1000mm		

* Weitere Größen auf Anfrage / Other sizes by request / Autres des tailles par demande
Otras medidas mediante consulta / Otras medidas bajo consulta.

TEXTFIX LIGHT

TexFix Light Canvas Profile (BIG SIZES)

 Aluminium-Profil-Lichtsystem für den Innen-Montage Leinwand. Speziell für große Flächen konzipiert.

 Aluminium profile light system for indoor assembly canvas. Specially designed for large areas.

 Profil en aluminium système pour toile de montage à l'intérieur de la lumière. Spécialement conçu pour les grandes surfaces.

 Sistema de perfil con luz adecuado para lonas gigantes o grandes áreas. Exterior e interior.

 Sistema de perfil con luz adecuado para lonas gigantes o grandes áreas. Exterior e interior.

* Verfügbar auf Anfrage / Available by request / Disponible sur demande / Disponível por solicitação / Disponible bajo pedido.

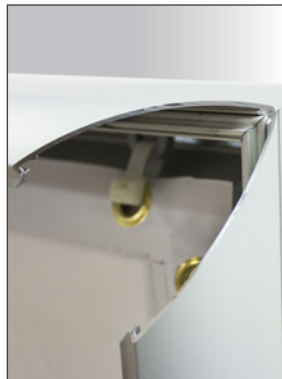
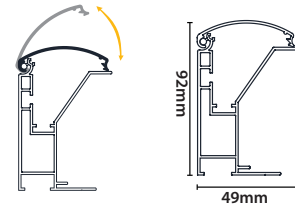
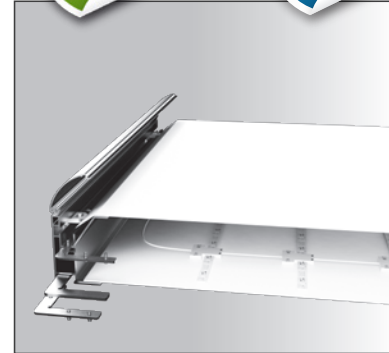

1

Base Straight



	QTY	N.W(kg)	G.W(kg)	C.B.M.	Size(mm)
Packing	1	5.9	6.1	0.0031	175x35x510

13.175 160x450mm x2

Base "S"



	QTY	N.W(kg)	G.W(kg)	C.B.M.	Size(mm)
Packing	1	4.5	4.7	0.0031	175x35x510

13.174 145x500mm x2

Hangers - TexFix Frame 16mm



	QTY	N.W(kg)	G.W(kg)	C.B.M.	Size(mm)
Packing	20	0.31	0.45	0.0004	85x45x115

13.172 x20

Hangers

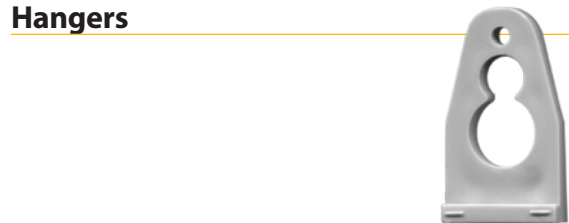

	QTY	N.W(kg)	G.W(kg)	C.B.M.	Size(mm)
Packing	1	0.047	0.01	0.00004	65x10x65

10.197 x10

Corner Connectors



13.171 x20



13.243 x20



13.333 x20

Central Connector Profile

Sonderprofile: Lieferumfang 4 Stück auf 3m Länge. Insgesamt 12m.

Aluminium profile in linear meters includes 4 units and each has 3m long. Total 12m.

Profil vendu au mètre linéaire et fournis en pack de 4 barres de 3m linéaires. Total 12m.

Perfil de alumínio em metros lineares inclui 4 barras com 3m de comprimento cada. Total 12m.

Perfil de aluminio en metros lineales, incluye 4 uni de 3m de longitud. Total 12m.

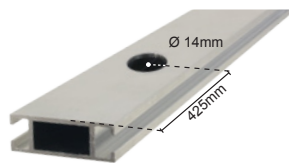

13.246 Pack 4 uni. x 3m/l = 12m/l

Hangers - TexFix Canvas



13.334 x1

Silicon Strip

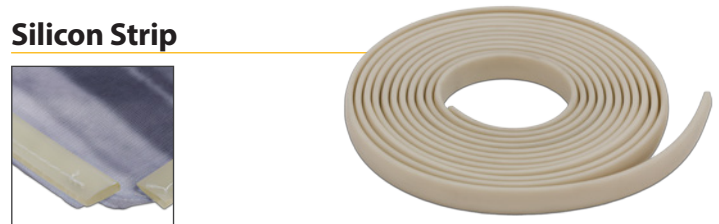

	QTY	N.W(kg)	G.W(kg)	C.B.M.	Size(mm)
Packing	1	0.45	0.52	0.0021	100x80x265

13.173 10 mts./l

Lock

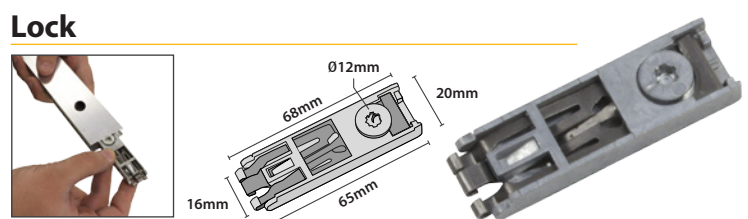

13.244

PanelFix Wing Steel

🇩🇪 Diese Basis besteht aus zwei Teilen, die verschraubt werden müssen, um den Vorstand zu unterstützen. Die Basis passt sich an die Dicke der Platte. Dies darf die Höhe 1500 mm nicht überschreiten.

🇬🇧 Aluminium base for the placement of rigid elements. Available in 2 widths, 300 and 500mm. Allows the fixing of supports up to 20 mm. The maximum recommended height for the graphic is 1500 mm. Allows the printing of any logo on both sides of the base.

🇫🇷 Base en acier pour l'exposition de visuels rigides. En fonction de sa position, il permet le maintien de supports jusqu'à 20mm d'épaisseur. Disponible en 2 largeurs : 300mm et 500mm. La hauteur maximale suggérée du visuel est de 1500mm.

🇧🇷 Esta base é composta por duas partes que devem ser aparafusadas para sustentar a placa. A base adapta-se à espessura da placa. Esta não deve superar os 1500 mm de altura.

🇪🇸 Base de acero para colocación de elementos rígidos. Disponible en 2 anchos, 300 y 500mm. Permite la sujeción de soportes hasta 20mm. La altura máxima recomendada para la gráfica es de 1500mm. Permite la impresión de cualquier logo en ambos lados de la base. Acero.

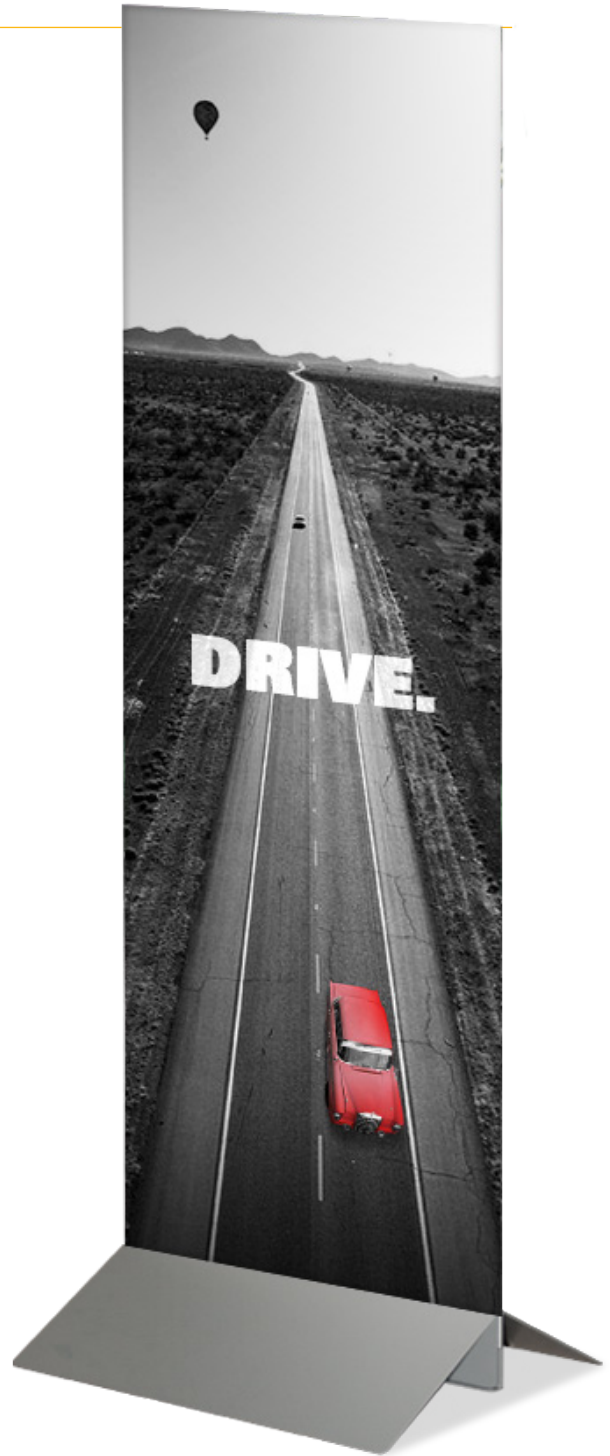
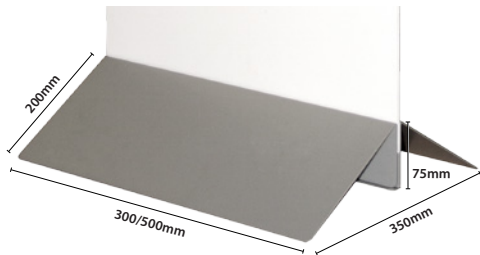
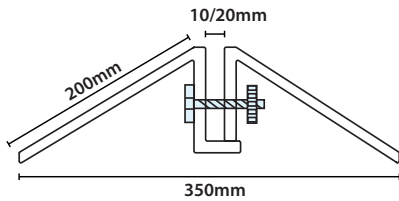

	QTY	N.W(kg)	G.W(kg)	C.B.M.	Size(mm)
Packing	1	2.75	2.95	0.0069	210x100x330
10.065		300mm			

	QTY	N.W(kg)	G.W(kg)	C.B.M.	Size(mm)
Packing	1	4.55	4.85	0.011	210x100x530
10.066		500mm			

POSTER DISPLAY

1

PanelFix Wing Aluminium

 Display - Halter aus Aluminium für starre Grafiken, für Grafiken mit 3mm bis 26mm Stärke, verfügbar in zwei Breiten 200mm, 350mm und 550mm.

 Aluminium base support for the placement of rigid graphics. Depending of its placement, this can be used with graphic thickness of 3mm up to 26mm. Available in 3 different sizes, 200mm, 350mm and 550mm.

 Base en aluminium pour l'exposition de visuels rigides. En fonction de sa position, il permet le maintien de supports de 3mm à 26mm d'épaisseur. Disponible en 3 largeurs: 200mm, 350mm et 550mm.

 Base de alumínio para colocar suportes de impressão rígidos, de 3mm a 26mm de espessura. Disponível em 200 mm, 350mm e 550mm.

 Base de aluminio para la colocación de soportes gráficos rígidos. Dependiendo de su colocación, permite la sujeción de soportes de 3mm a 26mm de espesor. Disponible en 3 anchos, 200mm, 350mm y 550mm.

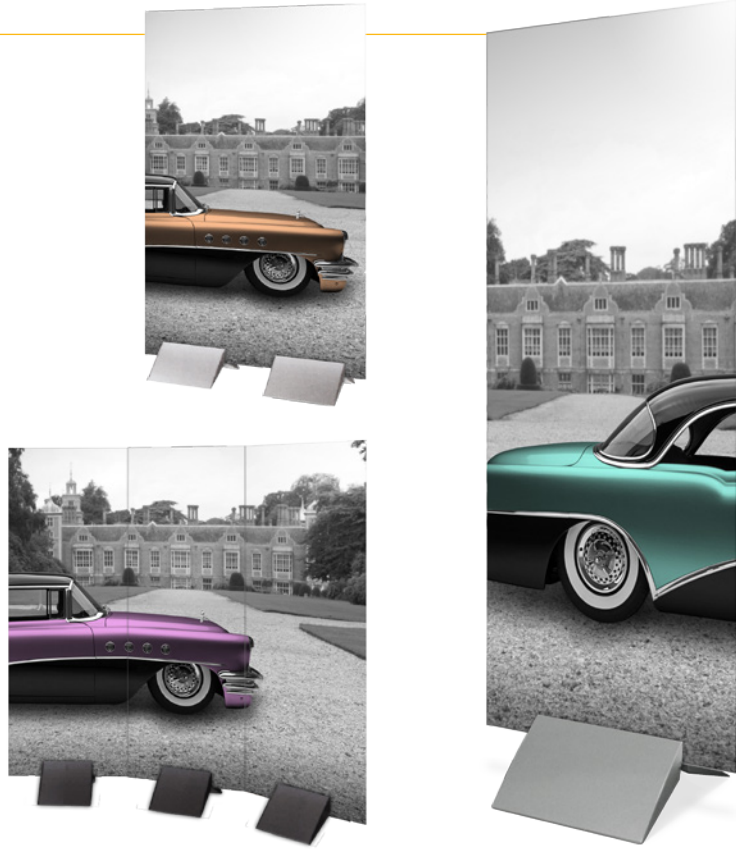
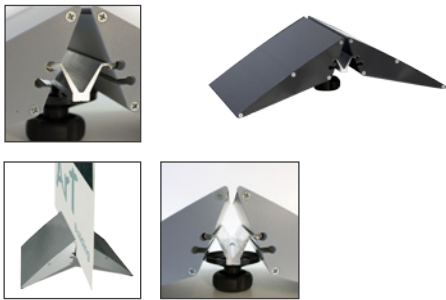

 Installation für Grafiken mit einer Stärke von 3-18mm.

 Installation for panel thickness of 3-18mm.

 Installation pour un panneau de 3-18mm d'épaisseur.

 Instalação para um painel de 3 a 18mm de espessura.

 Instalación para un panel de grosor de 3-18mm.

 Installation für Grafiken mit einer Stärke von 18-26mm.

 Installation for panel thickness of 18-26mm.

 Installation pour un panneau de 18-26mm d'épaisseur.

 Instalação para um painel de 18-26mm de espessura.

 Instalación para un panel de grosor de 18-26mm.

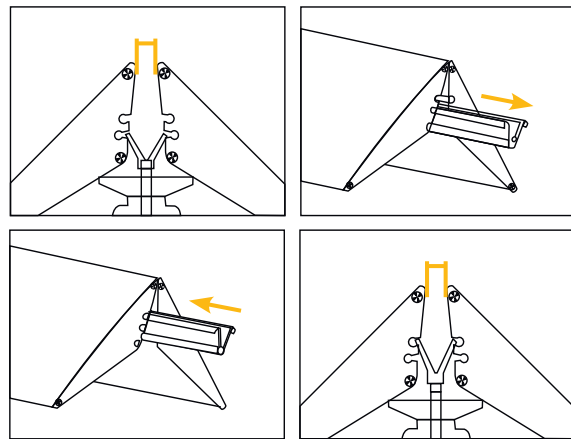
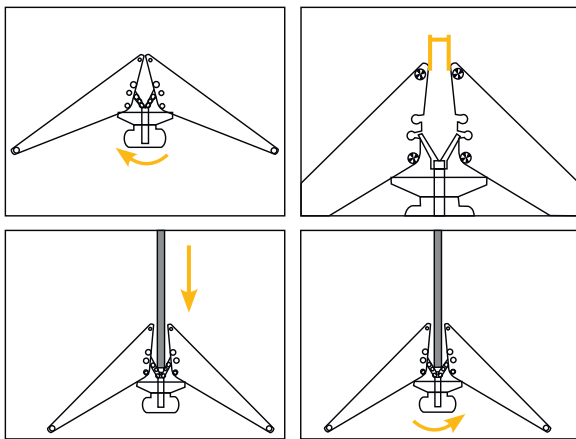

	QTY	N.W(kg)	G.W(kg)	C.B.M.	Size(mm)
Packing	1	1.1	1.5	0.0069	315x93x235

10.828 

10.829  200mm

	QTY	N.W(kg)	G.W(kg)	C.B.M.	Size(mm)
Packing	1	2.6	3	0.0113	315x93x385

10.877 

10.869  350mm

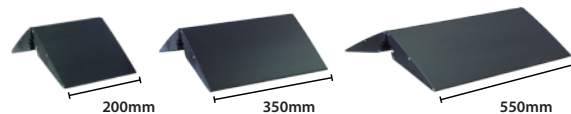



	QTY	N.W(kg)	G.W(kg)	C.B.M.	Size(mm)
Packing	1	4.15	4.6	0.0171	315x93x585

10.880 

10.870  550mm

Montijo

 Robuster Display - Halter aus Stahl, Stärke 6mm, Durchmesser 300mm, Höhe 200mm. Ideal für Grafiken mit 10mm Stärke.

 Steel support, ideal for placing metallic supports up to 10mm thickness. Sizes: 300mm diameter x 200mm high x 6mm thickness.

 Base métallique ronde en acier de 6mm d'épaisseur, 300mm de diamètre et 200mm de hauteur. Idéal pour visuels en carton léger ou compacts ayant une épaisseur maximum de 10mm.

 Base metálica com 300 mm de diâmetro e 200 mm de altura. Espessura painel: 6mm. Suporta impressões até 10 mm de espessura.

 Base metálica de 6mm de espesor. 300mm de diámetro y 200mm de alto. Ideal para colocación de soportes gráficos de hasta 10mm de espesor. Acero.

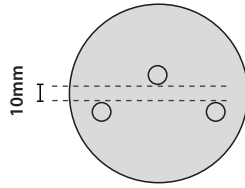

10.898



10.838





	QTY	N.W(kg)	G.W(kg)	C.B.M.	Size(mm)
Packing	2	7.2	7.75	0.024	310x250x310

10.898

10.838 Ø 300mm x2 

Balboa

 Robuster Display - Halter aus Stahl 5 mm dickes Metall. Maße 295x295 mm und 200mm hoch. Ideal für Ausstellung von Grafiken bis 11 mm Dicke. Stahl.

 Steel support, ideal for placing metallic supports up to 5mm thickness. Sizes: 295x295x200mm high x 11mm thickness.

 Base métallique de 5mm d'épaisseur. Mesures: 295*295mm et 200mm d'hauteur. Idéal pour l'exposition de visuels jusqu'à 11 mm d'épaisseur. Acier.

 Base metálica com 5 mm de espessura. Medidas 295x295 mm e 200 mm de altura. Suporta impressões até 11 mm de espessura. Aço.

 Base metálica de 5mm de espesor. Medidas 295x295mm y 200mm de alto. Ideal para colocación de soportes gráficos de hasta 11mm de espesor. Acero.

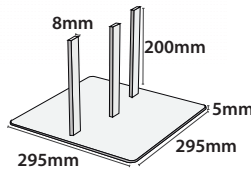
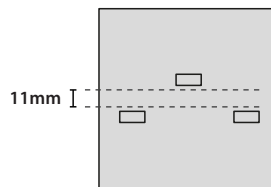

10.895



10.894



	QTY	N.W(kg)	G.W(kg)	C.B.M.	Size(mm)
Packing	2	9.00	9.60	0.024	310x250x310

10.894

10.895 295x295mm x2 

POSTER DISPLAY

1

PanelFix Wing Outdoor

Display - Halter aus Kunststoff für starre Grafiken, mit Wasser auffüllbar, verfügbar in Grau und Schwarz.

Refillable plastic base for the placement of rigid graphics. Available in gray or black colour. Plastic.

Base en plastique pour l'affichage de visuels rigides. Disponible en gris ou en noir.

Base de plástico que se pode encher com água. Disponível em preto ou cinzento.

Base de plástico rellenable para la colocación de gráficos rígidos. Disponible en gris o negro.

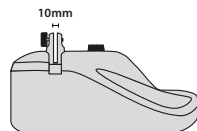

	QTY	N.W(kg)	G.W(kg)	C.B.M.	Size(mm)
Uni.	1	2	2.55	0.04	440x190x520

10.442

10.443

Steel Display

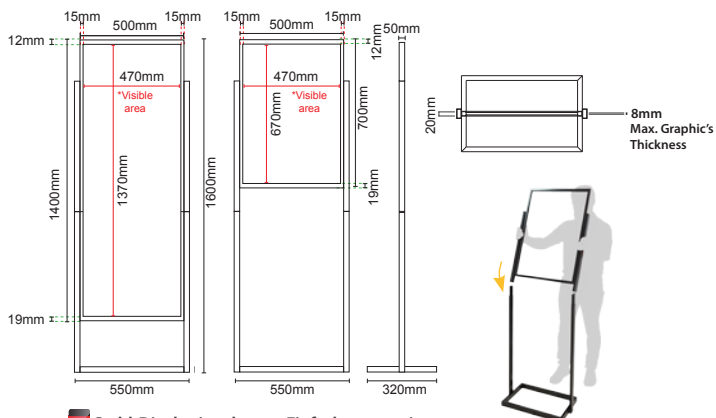

Stahl-Display in schwarz. Einfach zu montieren. Erhältlich in zwei verschiedenen Größen.

Steel Display painted in black colour. Easy to assemble. Available in two different sizes.

Structure en acier, facile à assembler. Disponible en deux dimensions. Couleur noir.

Expositor em aço de cor preta e de fácil montagem. Disponível em dois tamanhos.

Display fabricado en acero y lacado en color negro. Fácil de montar. Disponible en dos tamaños.

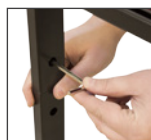

	QTY	N.W(kg)	G.W(kg)	C.B.M.	Size(mm)
Uni.	1	8.65	9.55	0.0459	570x100x805

10.996

	QTY	N.W(kg)	G.W(kg)	C.B.M.	Size(mm)
Uni.	1	9.5	10.4	0.0459	570x100x805

10.997

Algora

Display - Halter aus Metall, Verstellbare Höhe, 1000-1600mm.

Telescopic banner system. Adjustable height, 1000-1600mm.

Exposant métallique, réglable en hauteur, de 1000-1600mm.

Expositor ajustável em altura entre os 1000 e 1600 mm.

Expositor de metal, ajustable en altura, de 1000-1600mm.

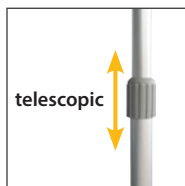

	QTY	N.W(kg)	G.W(kg)	C.B.M.	Size(mm)
Packing	1	1.2	1.6	0.02	270x70x1200

10.803 **840x1000-1600mm**



Oropesa

Mobiles Fahnenmastsystem aus Metall, geeignet für verschiedene Grafikmaterialien wie Leichtkarton oder Plane, Verstellbare Höhe, 1100-2100mm.

Telescopic banner system. Adjustable height, 1100-2100mm. It can accommodate several graphs like foam board or canvas.

Banner métallique, d'hauteur ajustable, de 1100-2100mm. On peut utiliser divers matériaux comme le carton ou la toile pour les visuels.

Expositor ajustável em altura entre os 1100 e 2100 mm.

Expositor de metal, ajustable en altura, de 1100-2100mm. Puede albergar gráficas de varios materiales como cartón pluma o lonas.



	QTY	N.W(kg)	G.W(kg)	C.B.M.	Size(mm)
Packing	1	1.96	2.53	0.05	410x118x1185

10.432 **360x1100-2100mm**

Extension Banner Vilamoura

Flexibles Präsentationssystem aus Stahl mit Farbauftrag, mittels Teleskopstangen kann es Ihrer gewünschten Grafikgröße angepasst werden.

- Grafikgröße: min. 945mm Höhe x 1300mm.
- Breite max. 2330mm Höhe x 2330mm Breite.

Telescopic banner system. The telescopic poles with adjustable height and width permit the use of different sizes of graphics. Easy disassembly for transportation. Steel, plastic parts.

- Minimum graphic size: 945mm high x 1300mm wide.
- Maximum graphic size: 2330mm high x 2330mm wide

Banner extensible fabriqué en acier peint. S'adapte sur différentes dimensions de visuel grâce à ses tubes télescopiques qui permettent l'extension verticale et horizontale du produit.

- Format minimum des visuels: 945mm d'hauteur x 1300mm de largeur.
- Format maximum des visuels: 2330mm d'hauteur x 2330mm de largeur.

Expositor ajustável em altura e comprimento. Leve e fácil de guardar para um melhor transporte. Fabricado em aço e plástico.

- Área de impressão mínima: 945mm altura x 1300mm largura.
- Área de impressão máxima: 2330mm altura x 2330mm largura.

Banner extensible fabricado en acero pintado. Ideal para adaptarse a distintos tamaños de gráfica gracias a sus tubos telescópicos que permiten la extensión tanto horizontal como vertical.

- Área gráfica mínima: 945mm alto x 1300mm ancho.
- Área gráfica máxima: 2330mm alto x 2330mm ancho.

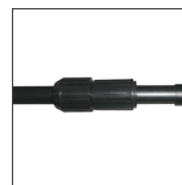

	QTY	N.W(kg)	G.W(kg)	C.B.M.	Size(mm)
Packing	1	6.6	8	0.027	240x115x1000

10.498 **Vilamoura**



QUICK SYSTEM

1

Quick System

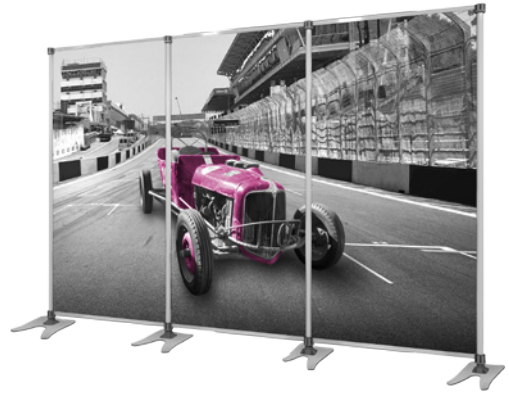
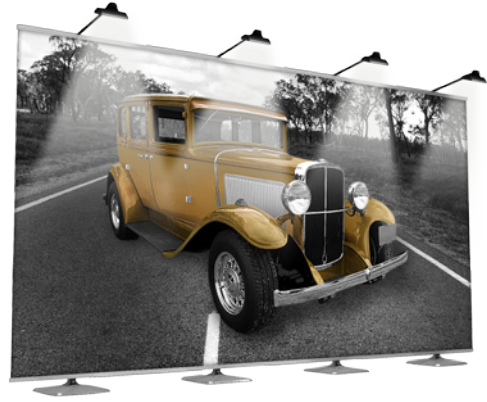
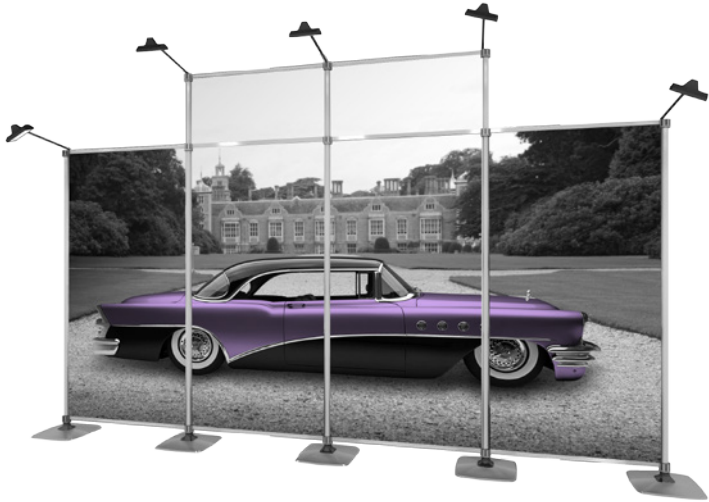

Modulares Präsentationssystem für Werbeplakate, ideal zum Kommunizieren Ihrer Werbeaussage, schneller und einfacher Auf- und Abbau.

System ideal for the display of posters, products and exhibit different communication needs. Quick and easy assembly.

Système d'exhibition idéal pour l'exposition d'affiches, de produits liés à la communication. Montage facile et rapide. Nombreuses combinaisons possibles.

Sistema de exposição para pontos de venda fácil e rápido de montar.

Sistema de exhibición ideal para la exposición de carteles, productos y distintas necesidades de comunicación. Fácil y rápido montaje.

Telescopic Pole

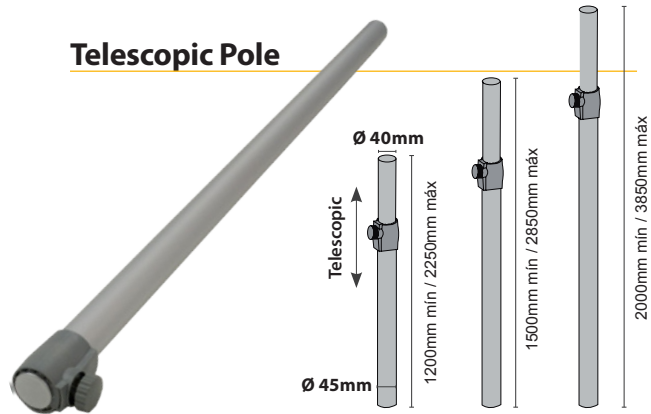

10.961	Ø 45x1200mm	
10.962	Ø 45x1500mm	
10.963	Ø 45x2000mm	

Pole's end Cap



10.966 x10

Base

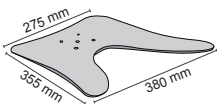
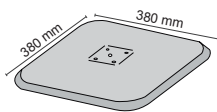

10.965 Base Feet

10.964 Base Square

Base Connector

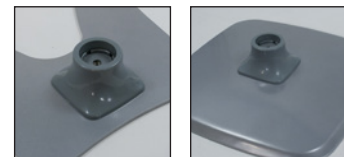
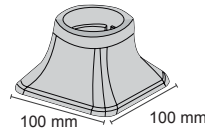

10.967

7 Ways connector

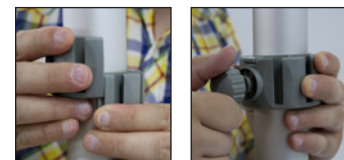
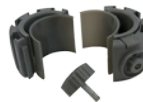
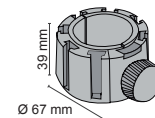

10.968

Alu Block

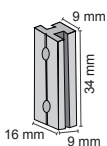
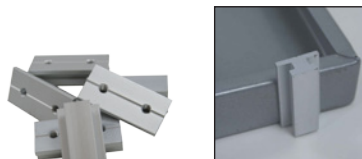

10.969 x10

Rail

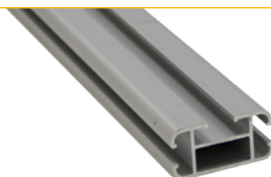
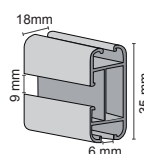

10.970 2 meter

1

PVC Insert

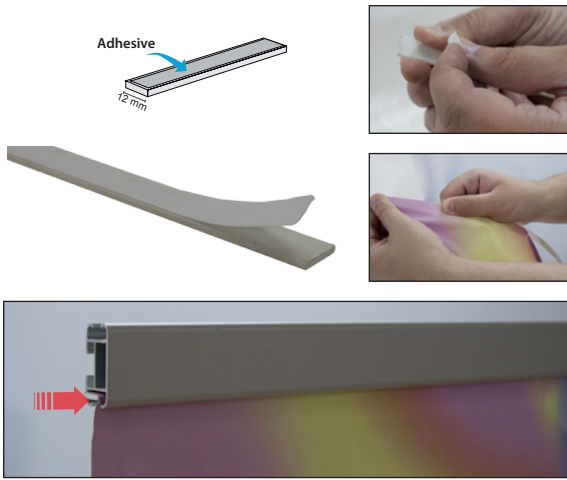

10.862 2 meter

Side Connecting Block

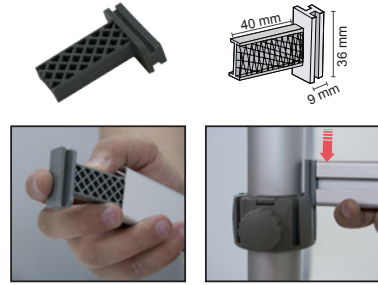

10.863 x10

Back connecting block

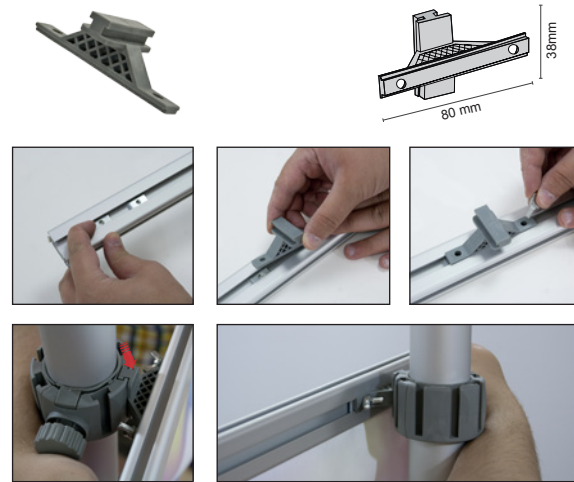

10.864 x10

Connecting Plate

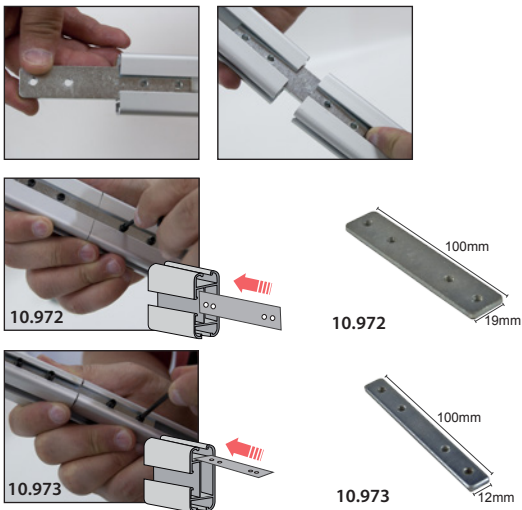

10.972 x10

10.973 x10

Wire clip



10.541 ø 45mm x10

10.542 ø 40mm x10

End Cap



10.971

Graphic Clip

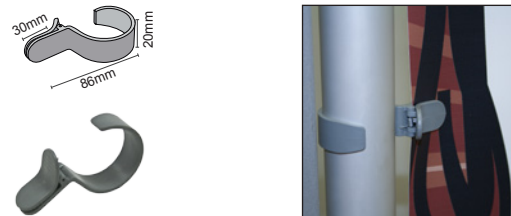

10.539 ø 45mm x10

10.540 ø 40mm x10

Plastic Clip

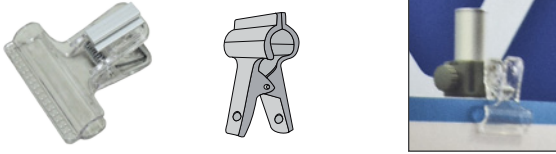

10.537

x10

Side Clip

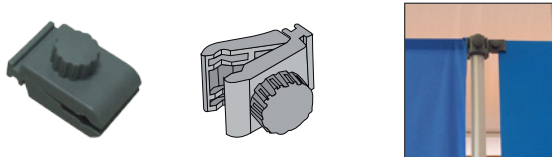

10.538

x10

LCD Bracket

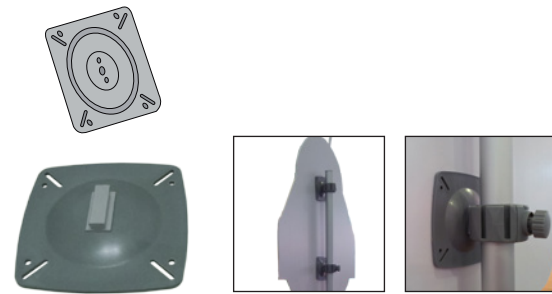

10.543

Acrylic Brochure Holder

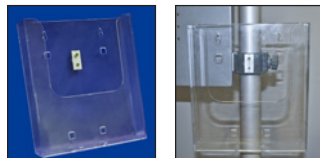

10.544

A4

10.545

A5

10.546

A6

Spotlight



10.389

Arc Shelf

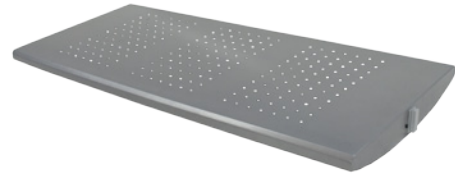

10.959

828x350mm

Shelf



10.960

825x400mm

Panel

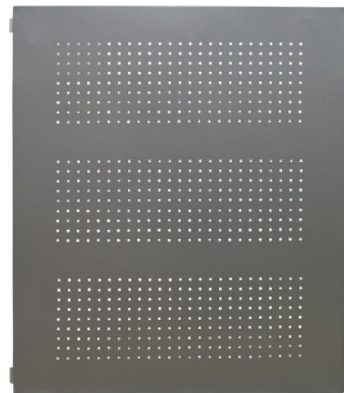

10.958

825x1000mm

Arc Light Box



10.957

825x285mm

PROMOTION COUNTERS

1

 Einfach und schnell zu montieren. Inklusive Transporttasche.

 Promotion counters for selling points. Quick and easy assembly. Fully removable. Includes carry bag.

 Comptoir d'accueil, rapide et facile à monter, valise de transport incluse.

 Balcão Promocional fácil e rápido de montar. Inclui saco de transporte.

 Mostradores para promoción en punto de venta. Fácil y rápido montaje. Totalmente desmontables. Incluyen bolsa de transporte.

Tavira

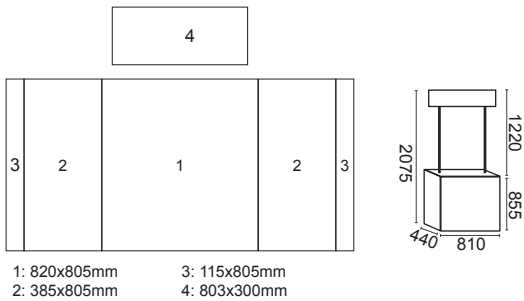

1: 820x805mm
2: 385x805mm
3: 115x805mm
4: 803x300mm

	QTY	N.W(kg)	G.W(kg)	C.B.M.	Size(mm)
Packing	1	7.35	8.95	0.073	840x100x880

10.098 **810x440x2075mm**



Salmoral

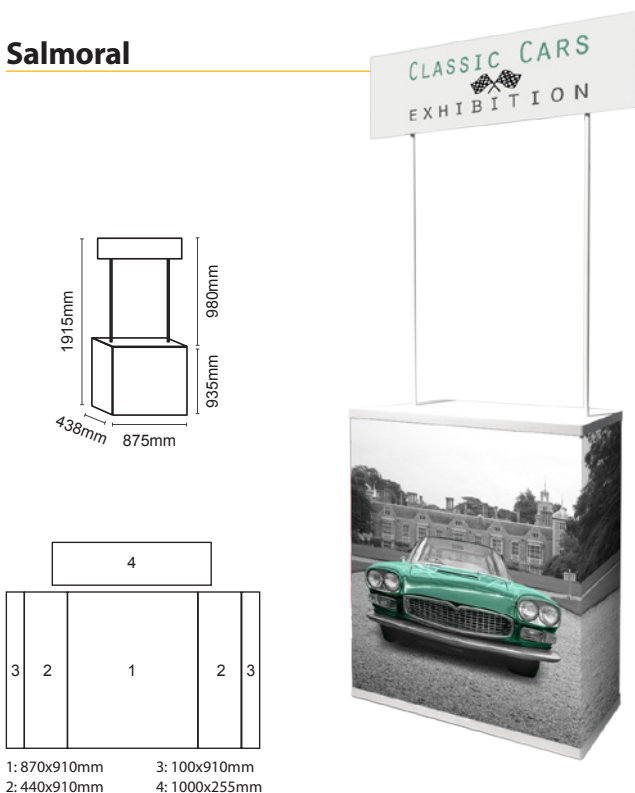

1: 870x910mm
2: 440x910mm
3: 100x910mm
4: 1000x255mm

	QTY	N.W(kg)	G.W(kg)	C.B.M.	Size(mm)
Packing	1	6.8	8.25	0.0510	560x70x1300

10.043 **875x438x1915mm**



Belvis

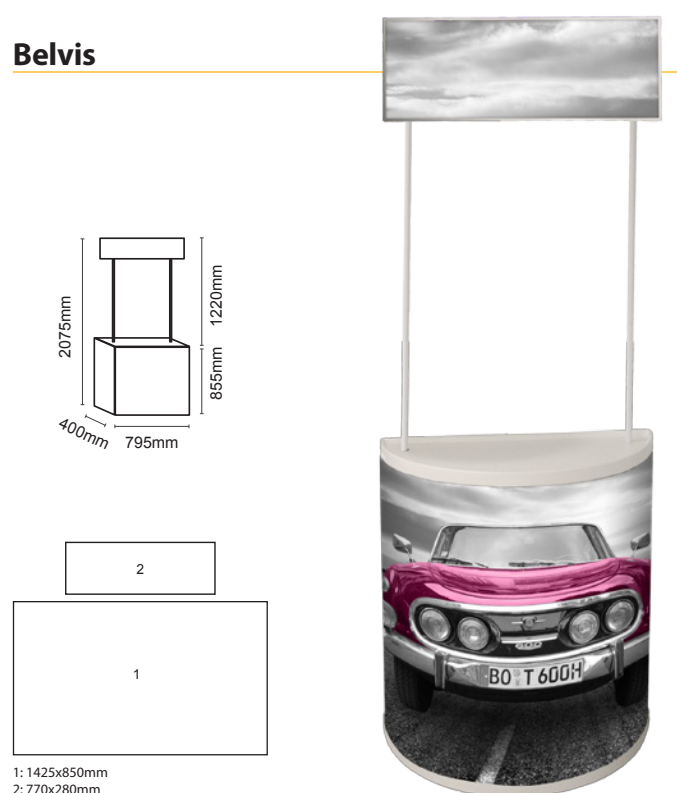

1: 1425x850mm
2: 770x280mm

	QTY	N.W(kg)	G.W(kg)	C.B.M.	Size(mm)
Packing	1	5.8	7.7	0.09	860x120x870

10.719 **795x400x2075mm**



PROMOTION COUNTERS

Manchester

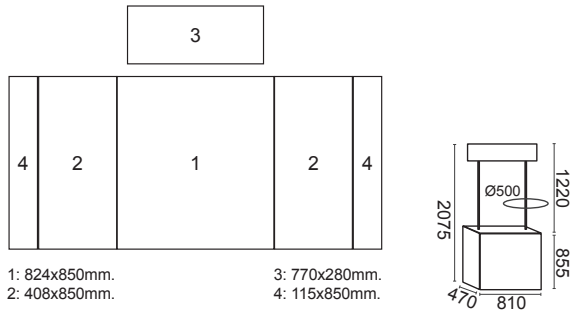

	QTY	N.W(kg)	G.W(kg)	C.B.M.	Size(mm)
Packing	1	9.5	10.5	0.08	860x110x880

10.676 **810x470x2075mm**



Lake

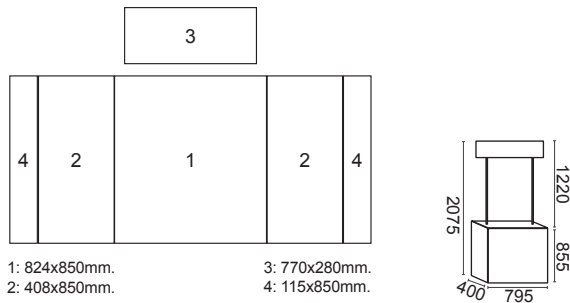

	QTY	N.W(kg)	G.W(kg)	C.B.M.	Size(mm)
Packing	1	8.5	9.5	0.08	860x110x880

10.675 **795x400x2075mm**



PROMOTION COUNTERS

1

Sigüenza



2	1	2
---	---	---

1: 1004x858mm.
2: 322x858mm.

	QTY	N.W(kg)	G.W(kg)	C.B.M.	Size(mm)
Packing	1	27	30	0.23	950x200x1250

10.493



Sepulveda



4	3	4
2	1	2

1: 1004x858mm 3: 1122x227mm
2: 322x858mm 4: 212x227mm

	QTY	N.W(kg)	G.W(kg)	C.B.M.	Size(mm)
Packing	1	36.8	41.9	0.18	940x160x1190

10.494



PROMOTION COUNTERS

Cebreros

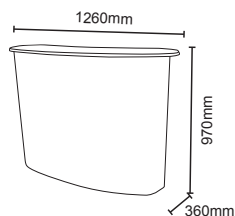

	QTY	N.W(kg)	G.W(kg)	C.B.M.	Size(mm)
Bottom	1	7.55	9.55	0.06	380x160x1030
Top	1	6.7	8.35	0.04	460x110x750

10.042 **2035x945mm**



Villares

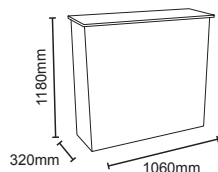

	QTY	N.W(kg)	G.W(kg)	C.B.M.	Size(mm)
Bottom	1	3.1	6.85	0.12	445x230x1130
Top	1	5.45	6.6	0.04	465x70x1120

10.096 **1770x1000mm**



PROMOTION COUNTERS

1

Cezures

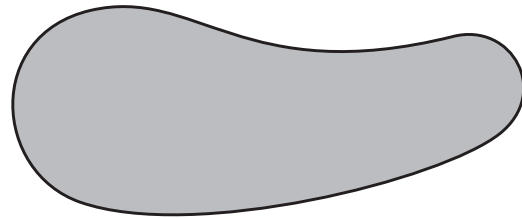
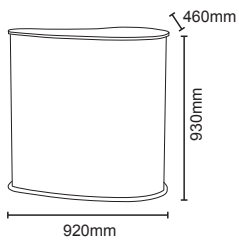

	QTY	N.W(kg)	G.W(kg)	C.B.M.	Size(mm)
Packing	2	7.7	15	0.02	570x380x940

10.686

1700x900mm



Doiras

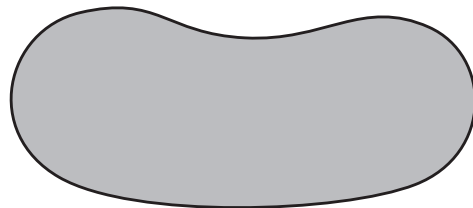
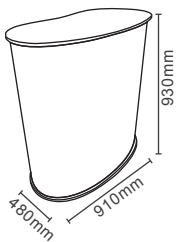
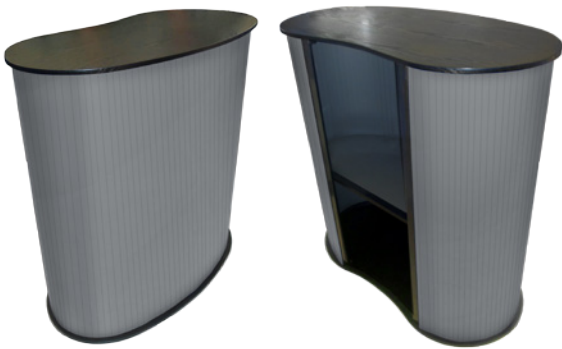

	QTY	N.W(kg)	G.W(kg)	C.B.M.	Size(mm)
Packing	2	12	13	0.0372	500x80x930
		1.5	2	0.0372	200x200x930

13.475



13.476



1850x900mm



PROMOTION COUNTERS

Valdes



	QTY	N.W(kg)	G.W(kg)	C.B.M.	Size(mm)
Packing	2	3.8	4.3	0.016	460x80x460
		2.7	3.2	0.037	200x200x930

10.685 1225x900mm



Libourne

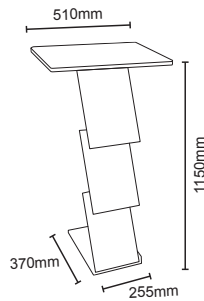

	QTY	N.W(kg)	G.W(kg)	C.B.M.	Size(mm)
Packing	1	7.35	7.8	0.03	400x160x540

10.417 510x370x980mm



Cardboard Display Counter Praga

🇩🇪 Messetheke in weiß. Kartondicke: 1,5mm, zwei Seiten weiß beschichtet / PVC. Druck im Preis nicht enthalten.

🇬🇧 Cardboard promotion counter. Cardboard's thickness 1.5mm, both sides are white coated / PVC. Printing is not included.

🇫🇷 Comptoir en carton de couleur blanche et 1,5mm d'épaisseur. Barres en PVC. Prix sans impression.

🇧🇷 Balcão promocional em cartão branco. Espessura do cartão: 1.5 mm. Impressão não incluída.

🇪🇸 Mostrador fabricado en cartón blanco estucado, 2 caras. e =1.5mm. Barras en PVC. Precio sin impresión.

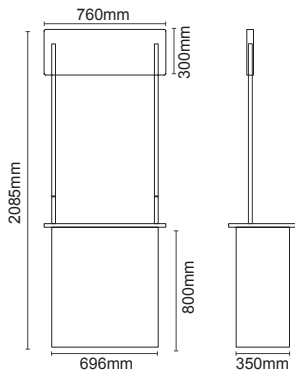

	QTY	N.W(kg)	G.W(kg)	C.B.M.	Size(mm)
Packing	1	3.05	3.9	0.0443	920x45x1070
10.730	696x350x2085mm				

Cardboard Promotion Counter Londres

🇩🇪 Messertheke in weiß. Dicke: 1,5mm, zwei Seiten weiß beschichtet / PVC. Regale: Dicke: 5mm, weiß beschichtet. Druck im Preis nicht enthalten.

🇬🇧 Cardboard promotion counter in white colour. Cardboard's thickness 1.5mm, both sides are white coated. Shelves: Cardboard thickness 5mm, both sides are white coated. Printing is not included.

🇫🇷 Présentoir fabriqué en carton blanc double face de 1,5mm d'épaisseur. Prix sans impression.

🇧🇷 Balcão promocional em cartão branco. Espessura do cartão: 1.5 mm. Espessura prateleiras: 5 mm. Impressão não incluída.

🇪🇸 Mostrador fabricado en cartón blanco estucado, 2 caras. e =1.5mm. Baldas fabricadas en cartón e=5mm. Precio sin impresión.

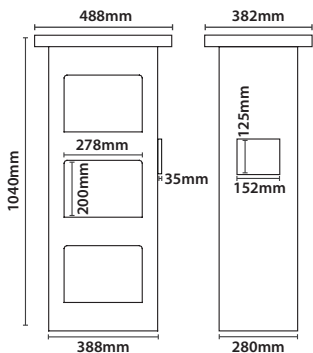

	QTY	N.W(kg)	G.W(kg)	C.B.M.	Size(mm)
Packing	1	1.35	2	0.0266	425x60x1045
10.733	488x382x1040mm				

Cardboard Dumpbin Accra

Sechskant-Aussteller in weiß, Karton an zwei Seiten weiß beschichtet. Druck im Preis nicht enthalten.

Hexagonal dumpbin. White colour. Cardboard, two white coated sides. Printing is not included.

Comptoir hexagonal fabriqué en carton blanc double face. Prix sans impression.

Balcão promocional com forma hexagonal fabricado em cartão de cor branca. Impressão não incluída.

Cesta hexagonal fabricada en cartón blanco 2 caras, Precio sin impresión.

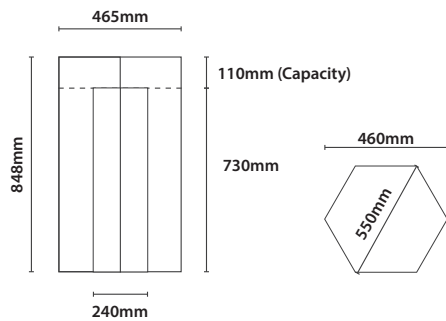

	QTY	N.W(kg)	G.W(kg)	C.B.M.	Size(mm)
Packing	1	1.35	2	0.018	830x25x910

13.466

Cardboard Dumpbin Lagos

Sechskant-Aussteller in weiß, Karton an zwei Seiten weiß beschichtet. Druck im Preis nicht enthalten.

Hexagonal dumpbin. White colour. Cardboard, two white coated sides. Printing is not included.

Comptoir hexagonal fabriqué en carton blanc double face. Prix sans impression.

Balcão promocional com forma hexagonal fabricado em cartão de cor branca. Impressão não incluída.

Cesta hexagonal fabricada en cartón blanco 2 caras, Precio sin impresión.

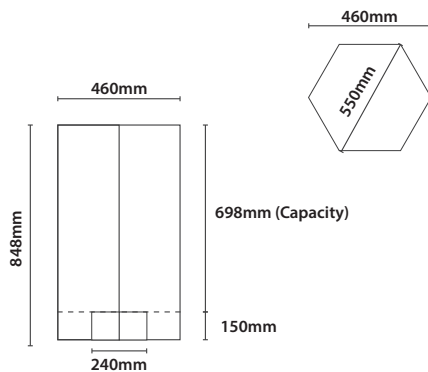

	QTY	N.W(kg)	G.W(kg)	C.B.M.	Size(mm)
Packing	1	1.35	2	0.018	830x25x910

13.467

Cardboard Dumpbin Berna

Aussteller in weiß, Kartonstärke: 3 mm, zwei Seiten weiß beschichtet. Druck im Preis nicht inbegriffen.

Cardboard dumpbin, both sides are white coated. Thickness 3mm. Filmstrip and printing are not included.

Présentoir en carton blanc, double face, de 3mm d'épaisseur. Etagères : 5mm.

Balcão promocional fabricado em cartão. Cor branca de ambos os lados. Espessura do cartão: 3 mm. Espessura prateleiras: 5 mm. Mica não incluída.

Cesta fabricada en cartón blanco 2 caras, e=3mm. Precio sin impresión. Filmina no incluida.

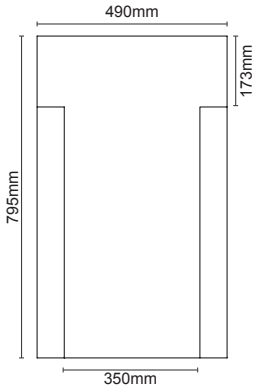

	QTY	N.W(kg)	G.W(kg)	C.B.M.	Size(mm)
Packing	1	1.15	1.8	0.0255	850x30x1000
10.732	490x490x795mm				

Cardboard Display Case 6 Pocket Oslo

Karton-Aussteller in weiß, Kartonstärke: 5 mm, zwei Seiten weiß beschichtet, Fächer: 6, Kartonstärke 1,5 mm, weiß beschichtet, Druck im Preis nicht inbegriffen.

Cardboard display in white colour.
Poster: cardboard's thickness 5mm, with two white coated sides.
Tray: cardboard's thickness 1.5mm, with two white coated sides.
Base: Cardboard's thickness 5mm, two white coated sides.
Printing is not included.

Présentoir en carton blanc double face.
Poster: 5mm.
Étagère: 1,5mm.
Base: 5mm.
Prix sans impression.

Balcão promocional fabricado em cartão.
Cor branca de ambos os lados.
Espessura do cartão: 5mm.
Prateleira: 1,5mm.
Base: 5mm.
Impressão não incluída.

Display fabricado en cartón blanco.
Cartela fabricada en canal medio blanco estucado 2 caras, e=5mm.
Cubeta fabricada en microcanal blanco estucado 2 caras, e=1.5mm.
Base fabricada en canal medio blanco estucado 2 caras, e=5mm.
Precio sin impresión.

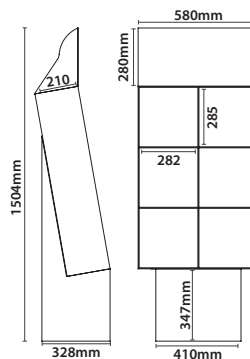

	QTY	N.W(kg)	G.W(kg)	C.B.M.	Size(mm)
Packing	1	2.8	3.9	0.2196	820x255x1050
10.731	580x328x1500mm				

Cardboard Floor Display Viena

Karton-Aussteller in weiß, Kartonstärke: 3 mm, zwei Seiten weiß beschichtet. Druck im Preis nicht inbegriffen.

Cardboard promotion counter in white colour. Cardboard's thickness 3mm, with two white coated sides. Printing is not included.

Présentoir en carton blanc, double face, 3mm d'épaisseur. Prix sans impression.

Balcão promocional fabricado em cartão. Cor branca de ambos os lados. Material: Cartão com espessura de 3mm. Impressão não incluída.

Display fabricado en cartón blanco estucado, 2 caras. e=3mm. Precio sin impresión.

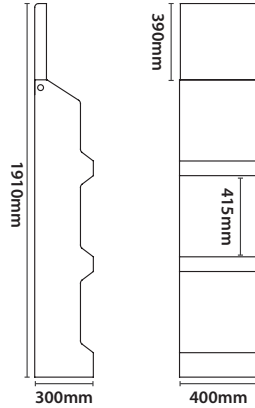

	QTY	N.W(kg)	G.W(kg)	C.B.M.	Size(mm)
Packing	1	1.1	1.7	0.0222	720x20x1540
10.734	400x300x1910mm				

Cardboard Hook Display Budapest

Karton Aussteller mit Haken aus weiß beschichtetem Karton, Stärke 1,5 mm. Druck und Haken nicht inbegriffen. Schneller und einfacher Aufbau. Haken nicht inbegriffen.

Cardboard hook display. Cardboard's thickness 1.5mm, with two white coated sides. Printing and hooks are not included. Easy assembly.

Présentoir en carton blanc, double face, de 1,5mm d'épaisseur. Impression et accroches non inclus.

Display para ganchos em cartão. Cor branca. Cartão com espessura de 1,5mm, branco de ambos lados. Preços não incluem mica adesiva. Preços não incluem ganchos. Configuração faça você mesmo.

Display fabricado en cartón blanco estucado, 2 caras, e=1.5mm. Impresión y ganchos no incluidos. Fácil montaje.

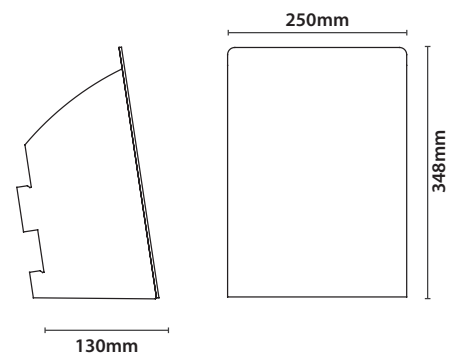
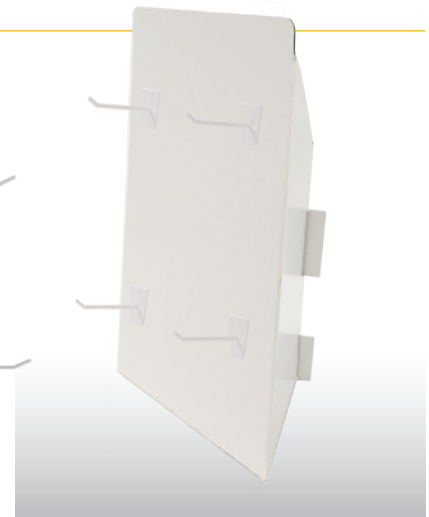
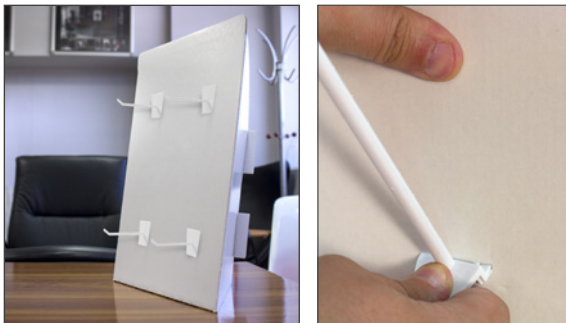

	QTY	N.W(kg)	G.W(kg)	C.B.M.	Size(mm)
Packing	5	0.1050	0.525	0.0038	260x35x415
10.831	250x350mm	x5			

1 Cardboard Counter Top Display Burdeos

Karton -Aussteller aus weiß beschichtetem Karton, Stärke 1,5 mm. Druck im Preis nicht inbegriffen.

Cardboard counter top display. Cardboard's thickness 1.5mm, with two white coated sides. Printing is not included.

Présentoir en carton blanc, double face, de 1,5mm d'épaisseur. Prix sans impression.

Display promocional fabricado em cartão. Cor branca de ambos os lados. Material: Cartão com espessura de 1,5mm. Preços não incluem impressão.

Display fabricado en cartón blanco estucado, 2 caras. e =1.5mm. Precio sin impresión.

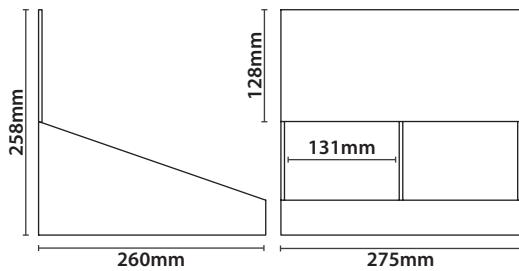

	QTY	N.W(kg)	G.W(kg)	C.B.M.	Size(mm)
Packing	5	1.1	1.44	0.0123	490x45x560
10.868	275x260x258mm	x5			

Carboard Brochure Stand Belgrado

Karton-Prospektständer in weiß, Kartonstärke 1,5 mm, 2 Seiten weiß beschichtet. Druck im Preis nicht inbegriffen.

Cardboard brochure stand in A5 size. Cardboard's thickness 1.5mm, with two white coated sides. Prices not includes printing.

Présentoir porte brochures A5, fabriqué en carton blanc, double face, de 1,5mm d'épaisseur. Prix sans impression.

Porta-folhetos fabricado em cartão. Cor branca de ambos os lados. Bolsa tamanho A5. Cartão com espessura de 1,5mm. Preços não incluem impressão.

Display fabricado en cartón blanco estucado, 2 caras. e =1.5mm. Precio sin impresión.

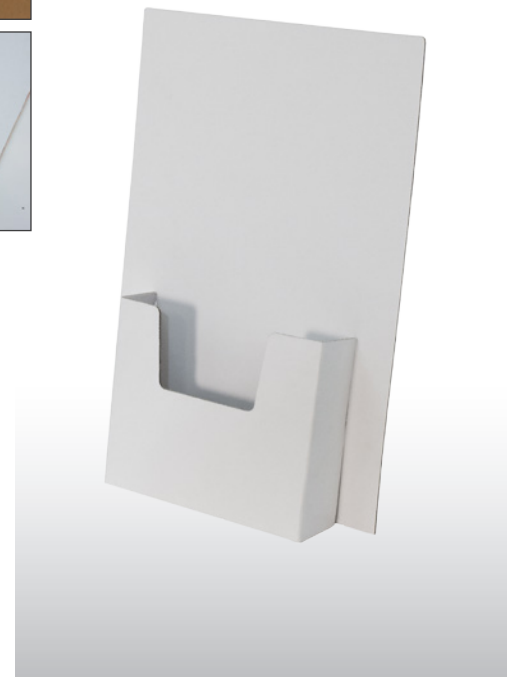
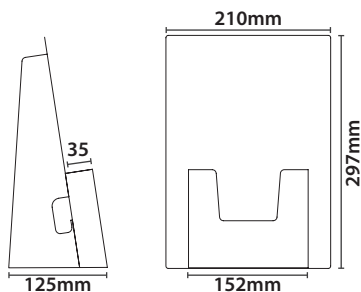
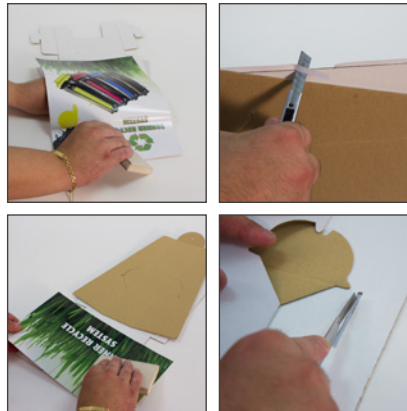

	QTY	N.W(kg)	G.W(kg)	C.B.M.	Size(mm)
Packing	5	0.33	0.5	0.0034	275x40x310
10.881	210x125x297mm	x5			

Adhesive Showcard

 Grafiktasche oder Klebeband an Ober- und Unterseite. Material PVC.











 Adhesive Showcard in transparent colour with adhesive on the top and bottom back part for better clamping.

 Porte affiches comprenant un adhésif à l'arrière sur la partie haute et basse permettant une meilleure fixation.

 Mica em PVC transparente com adesivo.

 Filmina de PVC con adhesivo superior e inferior en la parte posterior para mayor sujeción.





13.428	A1	0.4mm	x10 	
13.429	A2	0.4mm	x10 	
13.064	A3	0.4mm	x10 	
13.065	A4	0.4mm	x10 	
13.066	A5	0.4mm	x20 	
13.067	A6	0.4mm	x20 	
13.430	A7	0.4mm	x30 	

Plastic Display Caster

 Kunststofffüße für Bodendisplays. Verhindert Verschmutzung und schnelle Abnutzung der Grafikkanten, durch die Vermeidung von Bodenkontakt.

 Plastic feet for reinforcing the cardboard displays. Raises the cardboard display to avoid the contact with the ground.

 Pieds de plastique pour le renfort de display en carton. Èlève le display de carton pour éviter le contact avec le sol.

 Pé de plástico para reforçar os displays de cartão. Eleva os displays de cartão para evitar o contacto com o chão.

 Patas de plástico para el refuerzo de los displays de cartón. Elevan el display de cartón para evitar el contacto con el suelo.

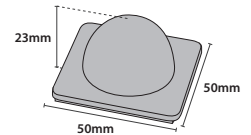

12.287	Adhesive	x50 	
--------	----------	---	--

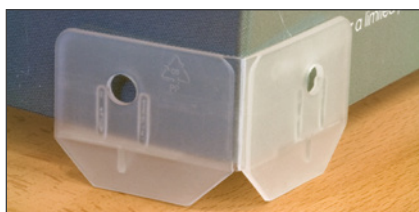
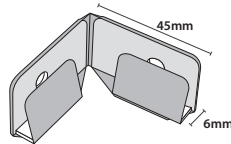
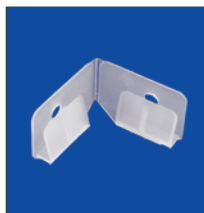

12.286	Simple	x50 	
--------	--------	---	--

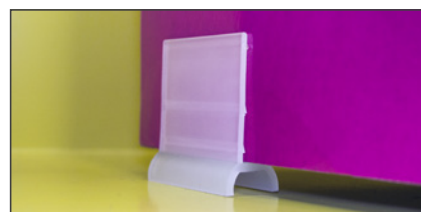
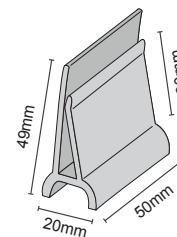

12.518	x100 	
--------	--	--

CARTON DISPLAY ACCESSORIES

1

Single Prong Quick-Stick

🇩🇪 Einfachhaken zur Befestigung an Pappwänden oder Displays aus Karton. Verfügbar in 6 verschiedenen Längen.

🇬🇧 Simple hook used for attaching to walls or directly on the cardboard displays. Available in 6 different sizes.

🇫🇷 Broche simple pour fixer directement au carton. Disponible en 6 dimensions.

🇵🇹 Gancho simples para fixar directamente ao cartão. Disponível em 6 medidas.

🇪🇸 Gancho simple para clavar directamente sobre el carton. Disponible en 6 medidas.

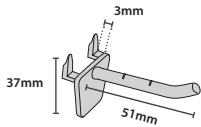

12.261 51mm x50

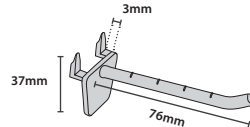

12.262 76mm x50

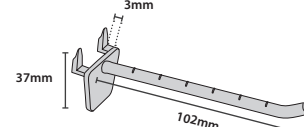

12.263 102mm x50

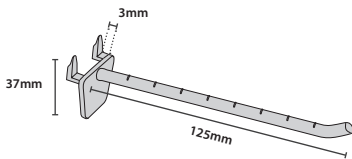

12.264 125mm x50

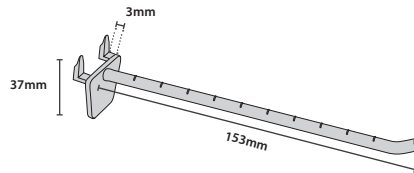

12.265 153mm x50

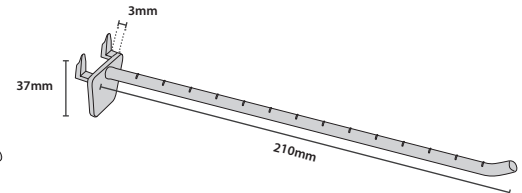

12.266 210mm x50

Insert Pegboard Flat

🇩🇪 Doppelhaken durchgehend, mit doppelter Halterung. Zur Befestigung an Pappwänden oder Displays aus Karton. Verfügbar in 3 verschiedenen Längen.

🇬🇧 Wide shovel hook to place in cardboard displays. Available in 3 different sizes. Plastic.

🇫🇷 Broche large pour la fixation sur display de carton. Disponible en 3 dimensions.

🇵🇹 Gancho de pá larga para colocar em displays de cartão. Disponível em 3 medidas.

🇪🇸 Gancho de pala ancha para colocar en displays de cartón. Disponible en 3 medidas.

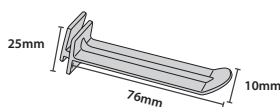
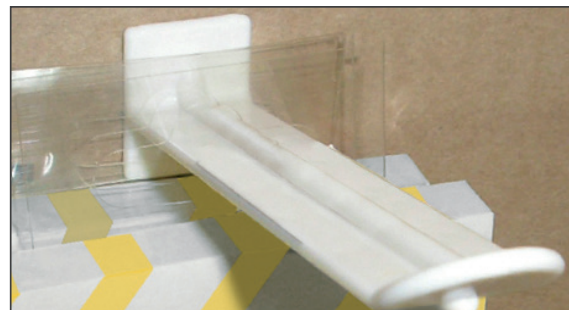

12.269 76mm x50

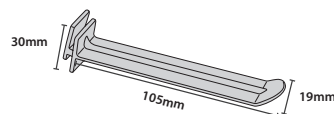

12.270 105mm x50

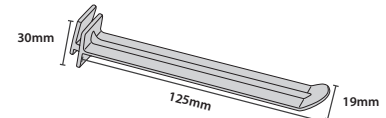

12.271 125mm x50

Insert Pegboard

Einfachhaken zur Befestigung an Pappwänden oder Displays aus Karton. Verfügbar in 5 verschiedenen Längen.

Simple hook used for attaching to walls or directly on the cardboard displays. 5 different sizes. Plastic.

Crochet simple, en plastique, pour fixation directe au carton. Disponible en 5 dimensions.

Gancho de plástico plano para fixar em cartão. Disponível em 5 tamanhos diferentes.

Gancho simple para clavar directamente sobre el cartón. Disponible en 5 medidas.

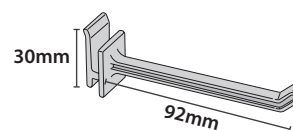
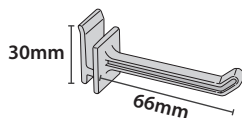
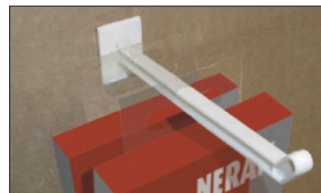

12.272 66mm x50

12.273 92mm x50

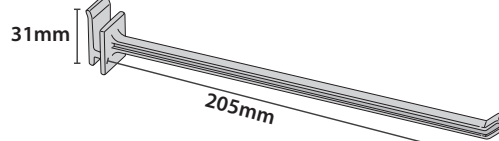
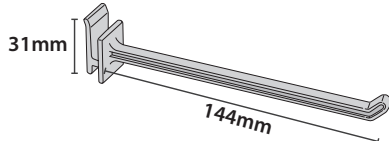
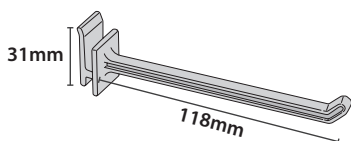

12.274 118mm x50

12.275 144mm x50

12.276 205mm x50

Double Hook

Einfachhaken mit Etikethalter zur Befestigung an Pappwänden oder Displays aus Karton.

Double hook for cardboard with price holder included. Plastic.

Broche pour carton avec porte étiquette.

Gancho duplo de plástico com porta preço.

Gancho para cartón con portaprecios incorporado.

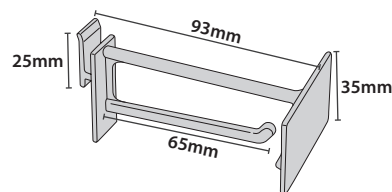
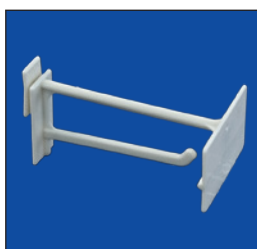

12.112 65mm x50

Pegboard for Slat Wall

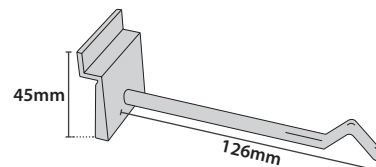
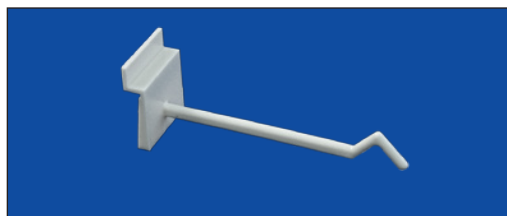

12.111 126mm x50

Insert Pegboard

Einfachhaken zur Befestigung an Pappwänden oder Displays aus Karton. Verfügbar in 2 verschiedenen Längen.

Simple hook for cardboard holder. Available in 2 sizes. Plastic.

Broche simple pour support de carton. Disponible en 2 dimensions.

Gancho de plástico. Disponível em 2 tamanhos diferentes.

Gancho simple para soporte de cartón. Disponible en 2 medidas. Plástico.

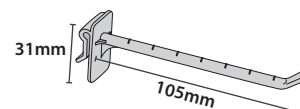

12.267 105mm x50

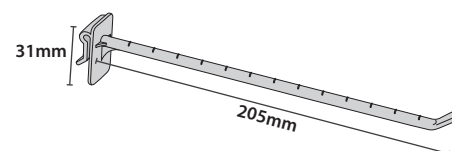

12.268 205mm x50

1

Cardboard Holders

Zwei ineinander greifende Elemente zur Unterstützung der Fachböden in Karton-Displays.

Two interlocking pieces for the support of shelves in cardboard displays. The larger size is designed to withstand heavy weights.

Equerre pour étagères en carton.

Conjunto de duas peças que se interligam para sustentar prateleiras de cartão.

Dos piezas ensamblables para el soporte de baldas en expositores de cartón.

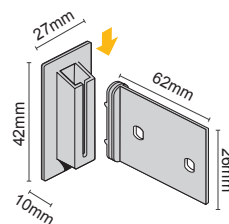
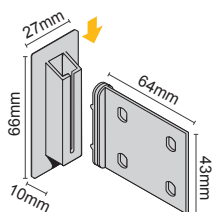
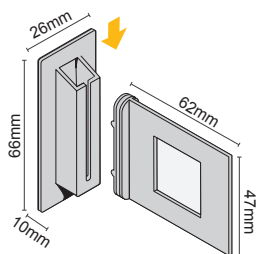
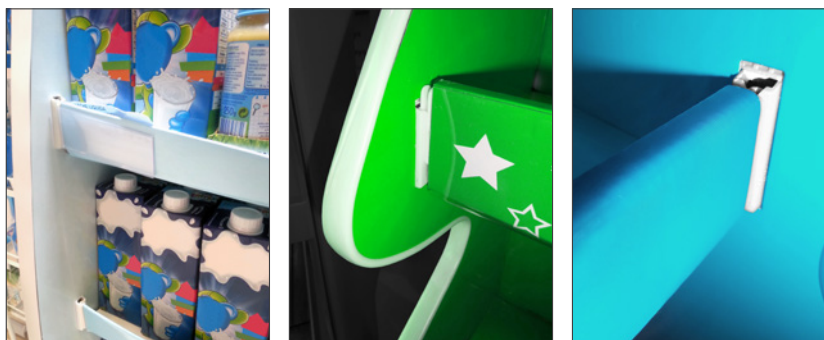

12.515

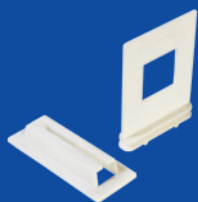

12.515

x50

12.516

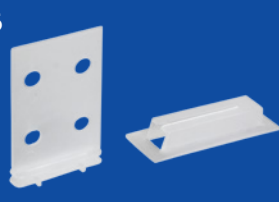

12.516

x50

12.517

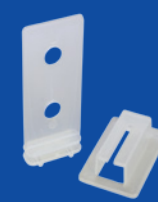

12.517

x50

Corrugated Bracket Clip

Transparente PVC-Clips zum Halten von Grafiken und Regalen.

Transparent PVC clip designed for holding graphics and shelves.

Support en pvc transparent pour fixation d'images et d'étagères.

Suporte de PVC para a fixação de imagens e prateleiras.

Clip transparente de PVC para soporte de gráficas y baldas.

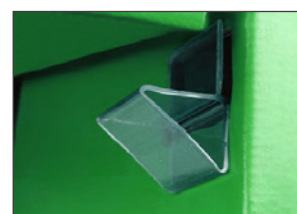
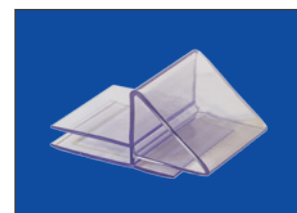
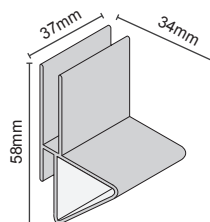
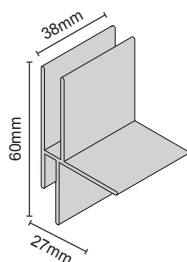
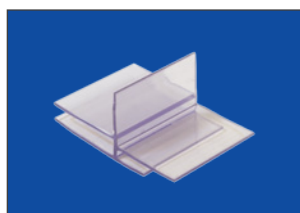

12.514

x50

12.513

x50

CARTON DISPLAY ACCESSORIES

Snap Rivet

🇩🇪 Druck-Öse zur Befestigung und Aufhängung von Schildern und Displays.

🇬🇧 Bolt and nut made of plastic for the positioning and fixing of posters.

🇫🇷 Vis et écrou réalisés en plastique pour la fixation de l'affichage.

🇩🇪 Tornillo y tuerca realizados en plástico para fijación de cartelera.

🇫🇷 Tornillo y tuerca realizados en plástico para fijación de cartelera.

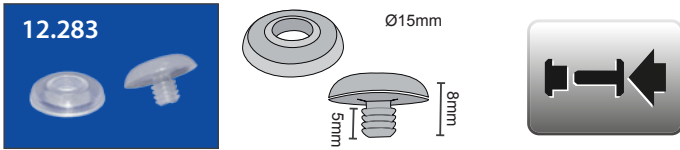

12.283

12.283 Ø15mm x50

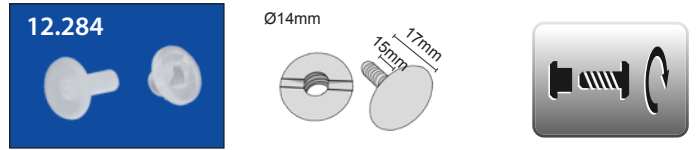

12.284

12.284 Ø14mm x50

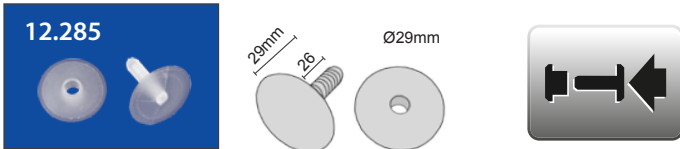

12.285

12.285 Ø29mm x50

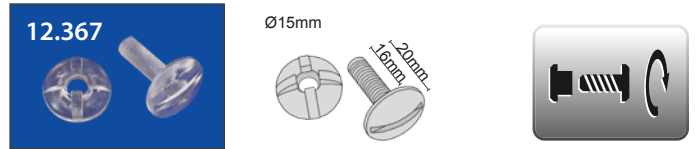

12.367

12.367 Ø15mm x50

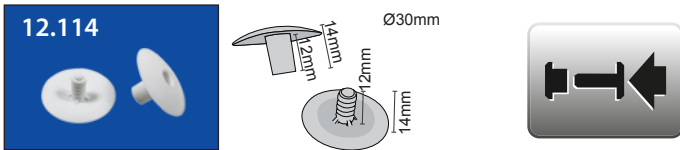

12.114

12.114 Ø30mm x50

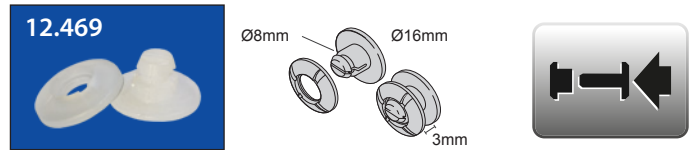

12.469

12.469 Ø16mm x100

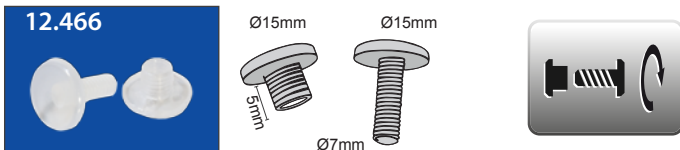

12.466

12.466 Ø15x8mm x100

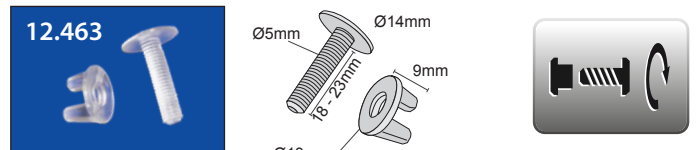

12.463

12.463 Ø14x18mm x100

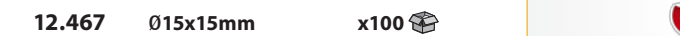

12.467 Ø15x15mm x100



12.464 Ø14x23mm x100



12.468 Ø15x20mm x100

Plastic Hook

🇩🇪 Weiße Kunststoffhaken.

🇬🇧 White plastic hook designed for placing it on cardboard. Available in two sizes.

🇫🇷 Crochet de plastique. Peut s'adapter à différents système ou directement à l'affiche.

🇩🇪 Gancho de plástico. Pode adaptar-se a diversos sistemas ou directamente ao cartaz.

🇫🇷 Gancho de plástico. Puede acoplarse a distintos sistemas o directamente a cartelera.



12.074 24x29 mm x50

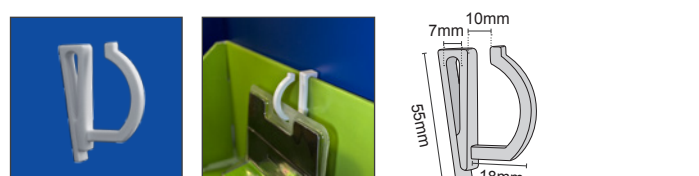

12.279 55x37mm x50

CARDBOARD EASEL

1

Cardboard Easel

 Kartonstaffelei. Farbe: White.

 Cardboard easel. Colour: White.

 Chevalet en carton blanc.

 Base para cartão. Cor Branca.

 Peanas para cartón. Color Blanco.

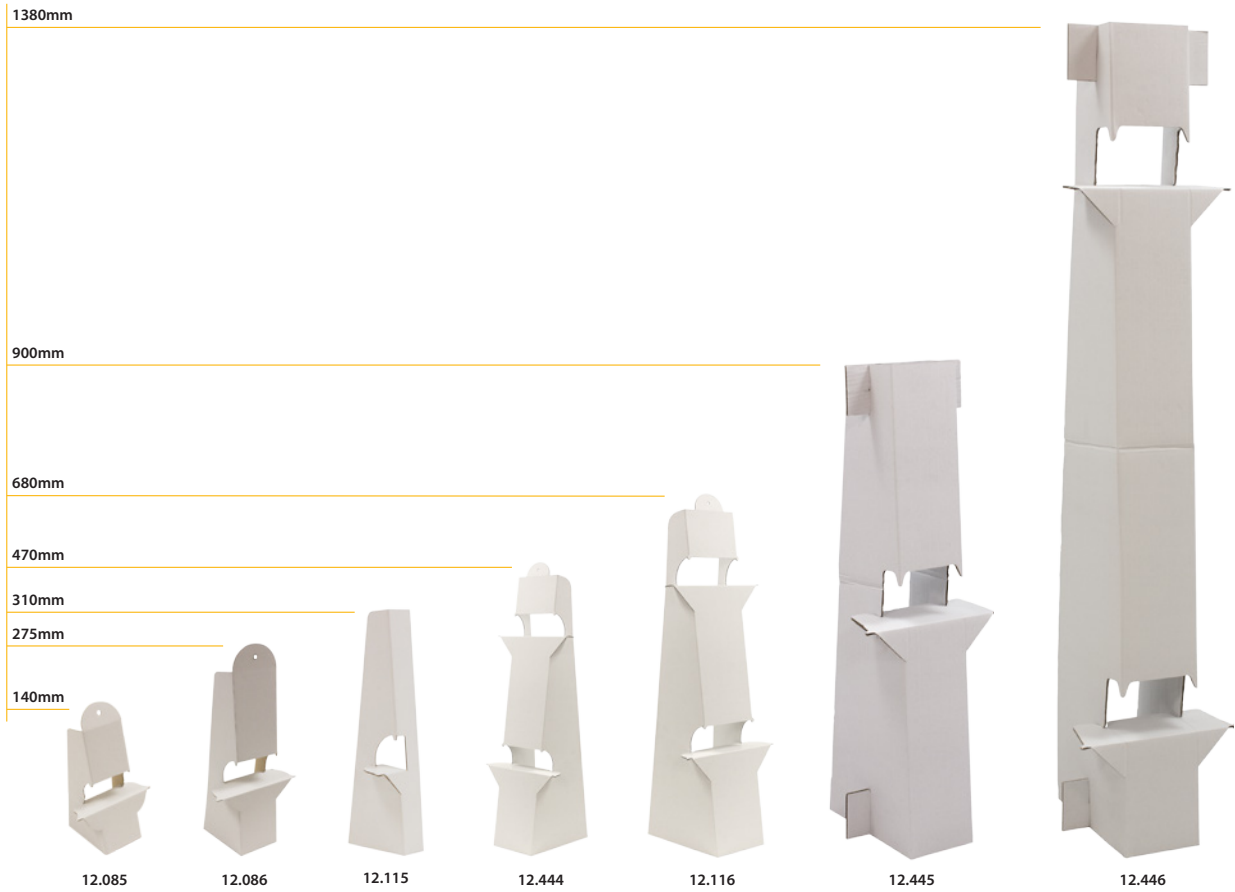

CARDBOARD EASEL



	QTY	N.W (kg)	G.W (kg)	C.B.M.	Size(mm)
Pack.	50	0.37	0.45	0.0029	170x85x200
12.085	140 mm	x50			



	QTY	N.W (kg)	G.W (kg)	C.B.M.	Size(mm)
Pack.	50	0.91	1.05	0.0073	250x85x340
12.086	275 mm	x50			

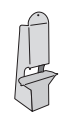

	QTY	N.W (kg)	G.W (kg)	C.B.M.	Size(mm)
Pack.	50	0.56	0.71	0.0056	240x65x365
12.115	310 mm	x50			

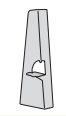

	QTY	N.W (kg)	G.W (kg)	C.B.M.	Size(mm)
Pack.	50	2	2.7	0.074	395x310x605
12.444	470 mm	x50			

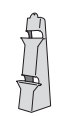

	QTY	N.W (kg)	G.W (kg)	C.B.M.	Size(mm)
Pack.	20	1.97	2.4	0.0171	565x40x760
12.116	680 mm	x20			

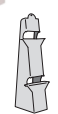

	QTY	N.W (kg)	G.W (kg)	C.B.M.	Size(mm)
Pack.	20	8	9.2	0.117	565x290x720
12.445	900 mm	x20			

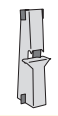

	QTY	N.W (kg)	G.W (kg)	C.B.M.	Size(mm)
Pack.	20	10	11.4	0.15	720x290x720
12.446	1380 mm	x20			

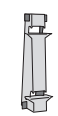

Sheets

Kartonagen. Erhältlich in Größen A3 und A4. Kartonstärke: 1,5 mm, weiß, zwei Seiten beschichtet.

Cardboard Sheets. Available in A3 and A4 sizes. Thickness 1.5mm, with two white coated sides.

Feuilles de carton blanc avec une épaisseur de 1,5 mm. Disponible en taille A4 et A3.

Folhas de cartão com uma espessura de 1,5 mm. Cor branca de ambos os lados. Disponível em A4 e A3.

Planchas de cartón blanco estucado, 2 caras. e =1.5mm.

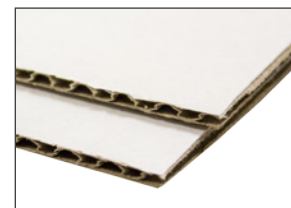

10.994	A4	x10	
10.995	A3	x10	

PVC Hanger

Aufhänger mit transparentem PVC-Kleber. Dicke 0,04 mm.

PVC hanger with transparent adhesive. Thickness: 0,04mm.

Support d'accroche en PVC transparent avec adhésif. Epaisseur 0,04mm.

Suporte de PVC transparente. Espessura: 0,04 mm.

Colgador de PVC con adhesivo transparente. Espesor 0,04mm.

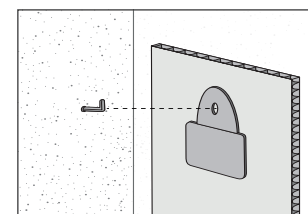
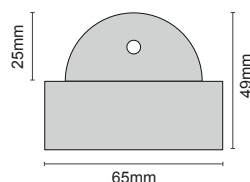

12.512	65x49mm	50 Uni.	
---------------	----------------	----------------	--

POSTER SYSTEM

1

CheapClip

Aufhänger - Set Cheapclip für Grafiken mittels Plastikclip, einfacher und schneller Grafikwechsel. Set enthält alle notwendigen Bestandteile für Montage (Kunststoffschiene und Aufhänger). Verfügbar in Schwarz, Weiß oder transparent.

Cheap Clip Kit system for graphical support through suspension. The changes of graphics can be done in a quick and easy way. Each kit contains all the needed elements for assembly: profile bar and hangers. Available in white, black or transparent.

Barre à clips pour suspension de visuel. Permet le changement rapide et simple des visuels. Kit complet (profil et anneaux). Disponible en blanc, noir et transparent.

Perfil de plástico adequado para impressões pesadas e grandes, não necessitando de ferramentas para a sua montagem. Cada kit inclui um perfil e suspensores. Disponível em preto, branco e transparente.

Kit sistema Cheapclip para soporte de gráfica mediante suspensión. Preparado para realizar los cambios de gráfica de manera rápida y sencilla. Contiene todos los elementos necesarios para su montaje (1 perfil y colgadores). Disponible en blanco, negro o transparente.

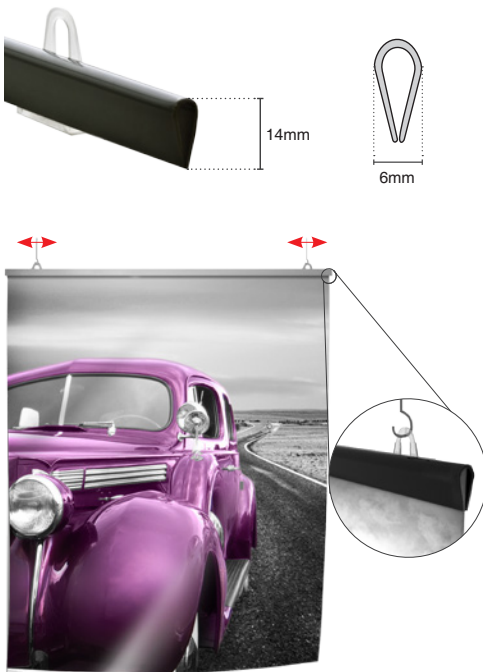

	QTY	N.W(kg)	G.W(kg)	C.B.M.	Size(mm)
Packing	12	0.16	0.36	0.014	360x80x520

10.621 clear

10.622

10.623 500mm x12

	QTY	N.W(kg)	G.W(kg)	C.B.M.	Size(mm)
Packing	12	0.28	0.48	0.023	360x80x820

10.624 clear

10.625

10.626 800mm x12

	QTY	N.W(kg)	G.W(kg)	C.B.M.	Size(mm)
Packing	12	0.36	0.56	0.029	360x80x1020

10.627 clear

10.628

10.629 1000mm x12

SoftClip

Aufhänger - Set Softclip für Grafiken mittels Plastikclip, einfacher und schneller Grafikwechsel. Set enthält alle notwendigen Bestandteile für Montage (Kunststoffschiene und Aufhänger). Verfügbar in Schwarz, Weiß oder transparent.

Soft Clip Kit system for graphical support through suspension. The changes of graphics can be done in a quick and easy way. Each kit contains all the needed elements for assembly: one plastic profile and hangers. Available in white, black or transparent.

Barre à clips pour suspension de visuel. Permet le changement rapide et simple des visuels. Kit complet (profil et anneaux). Disponible en blanc, noir et transparent.

Perfil de plástico adequado para impressões pesadas e grandes, não necessitando de ferramentas para a sua montagem. Cada kit inclui um perfil e dois suspensores. Disponível em preto, branco e transparente.

Kit sistema Softclip para soporte de gráfica mediante suspensión. Preparado para realizar los cambios de gráfica de manera rápida y sencilla. Contiene todos los elementos necesarios para su montaje (1 perfil de plástico y colgadores). Disponible en blanco, negro o transparente.

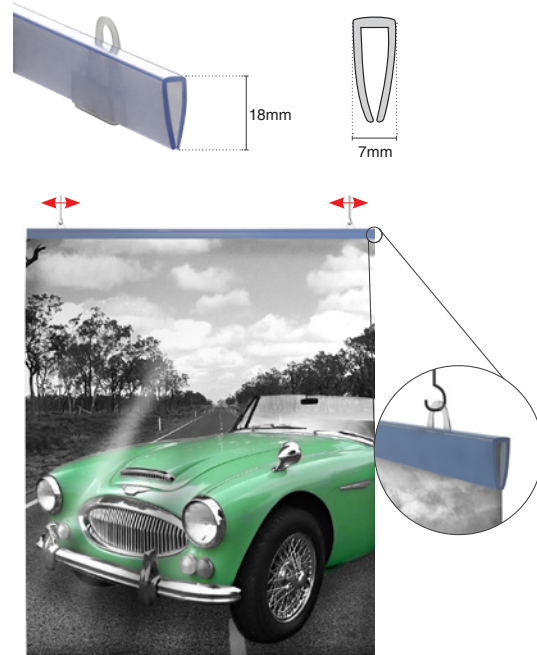

	QTY	N.W (kg)	G.W (kg)	C.B.M.	Size(mm)
Packing	12	0.28	0.4	0.014	360x80x520

10.612 clear

10.613

10.614 500mm x12

	QTY	N.W (kg)	G.W (kg)	C.B.M.	Size(mm)
Packing	12	0.52	0.72	0.023	360x80x820

10.615 clear

10.616

10.617 800mm x12

	QTY	N.W (kg)	G.W (kg)	C.B.M.	Size(mm)
Packing	12	0.72	0.91	0.029	360x80x1020

10.618 clear

10.619

10.620 1000mm x12

BestClip

Aufhänger - Set Bestclip für Grafiken mittels Plastikclip, einfacher und schneller Grafikwechsel. Set enthält alle notwendigen Bestandteile für Montage (Kunststoffschiene und Aufhänger). Verfügbar in 3 verschiedenen Farben.

PlastiClip System Kit for graphical support through suspension and graphic positioning system pressure of interior parts. The changes of graphics can be done in a quick and simple way. Contains all the needed elements for assembly (1 Profile and hangers). Available in 3 colors and measures.

Barre à clips pour suspension de visuel grand format. Permet le changement rapide et simple des visuels. Kit complet (profil et anneaux). Disponible en blanc, noir et transparent.

Perfil de plástico adequado para impressões pesadas e grandes, não necessitando de ferramentas para a sua montagem. Cada kit inclui um perfil e dois suspensores. Disponível em três cores.

Kit sistema Bestclip para soporte de gráfica mediante suspensión y sistema de colocación de gráfica por presión de la piezas interiores. Preparado para realizar los cambios de gráfica de manera rápida y sencilla. Contiene todos los elementos necesarios para su montaje (1 perfil y colgadores). Disponible en 3 colores.

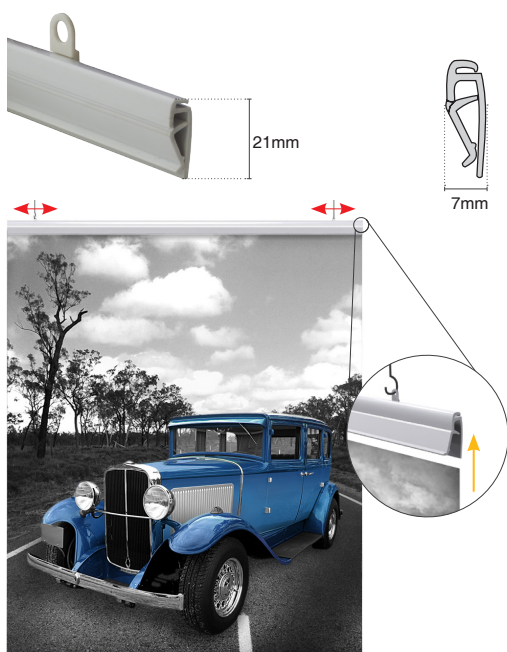

	QTY	N.W(kg)	G.W(kg)	C.B.M.	Size(mm)
Packing	12	0.4	0.6	0.014	360x80x520

10.603 clear

10.604

10.605 500mm x12

	QTY	N.W(kg)	G.W(kg)	C.B.M.	Size(mm)
Packing	12	0.64	0.84	0.023	360x80x820

10.606 clear

10.607

10.608 800mm x12

	QTY	N.W(kg)	G.W(kg)	C.B.M.	Size(mm)
Packing	12	0.72	0.92	0.029	360x80x1020

10.609 clear

10.610

10.611 1000mm x12

PlastiClip

Aufhänger - Set für Grafiken mittels Plastikclip, einfacher und schneller Grafikwechsel. Set enthält alle notwendigen Bestandteile für Montage (1 Kunststoffschiene und Aufhänger). Lieferbar in Schwarz oder Weiß. In fünf verschiedenen Größen verfügbar.

PlastiClip System Kit for graphical support through suspension and graphic positioning system pressure of interior parts. The changes of graphics can be done in a quick and simple way. Contains all the needed elements for assembly (1 Profile and hangers). Available in black or white and 5 different sizes.

Barre à clips pour suspension de visuel grand format. Permet le changement rapide et simple des visuels. Kit complet (profil et anneaux). Disponible en blanc et noir.

Perfil de plástico adequado para impressões pesadas e grandes, não necessitando de ferramentas para a sua montagem. A imagem muda-se abrindo a parte frontal do perfil. Cada kit inclui um perfil e dois suspensores. Disponível em preto, branco e transparente.

Kit sistema PlastiClip para soporte de gráfica mediante suspensión y sistema de cierre de presión. Preparado para realizar los cambios de gráfica de manera rápida y sencilla. Contiene todos los elementos necesarios para su montaje (1 perfil de plástico y colgadores). Disponible en color blanco o negro. Cinco medidas disponibles.



	QTY	N.W(kg)	G.W(kg)	C.B.M.	Size(mm)
Packing	12	0.48	0.68	0.004	130x90x440

10.526

10.527 440mm x12

	QTY	N.W(kg)	G.W(kg)	C.B.M.	Size(mm)
Packing	12	0.6	0.8	0.005	130x90x500

10.528

10.529 500mm x12

	QTY	N.W(kg)	G.W(kg)	C.B.M.	Size(mm)
Packing	12	0.72	0.92	0.007	130x90x600

10.530

10.531 600mm x12

	QTY	N.W(kg)	G.W(kg)	C.B.M.	Size(mm)
Packing	12	0.88	1.05	0.009	130x90x800

10.532

10.533 800mm x12

	QTY	N.W(kg)	G.W(kg)	C.B.M.	Size(mm)
Packing	12	1.08	1.2	0.01	130x90x1000

10.534

10.535 1000mm x12

StrongClip

Aufhänger - Set Strongclip für Grafiken mittels Plastikclip, einfacher und schneller Grafikwechsel. Set enthält alle notwendigen Bestandteile für Montage (1 Kunststoffschiene und Aufhänger). Verfügbar in Schwarz, Weiß oder transparent.

Strong Clip System Kit for graphical support through suspension and pressure lock system. The changes of graphics can be done in a quick and simple way. Contains all the needed elements for assembly (1 plastic profile and hangers). Available in white, black or transparent.

Barre à clips pour suspension de visuel grand format. Permet le changement rapide et simple des visuels. Kit complet (profil et anneaux). Disponible en blanc, noir et transparent.

Perfil de plástico adequado para impressões pesadas e grandes, não necessitando de ferramentas para a sua montagem. A imagem muda-se abrindo a parte frontal do perfil. Cada kit inclui um perfil e dois suspensores. Disponível em preto, branco e transparente.

Kit sistema Strongclip para soporte de gráfica mediante suspensión y sistema de cierre de presión. Preparado para realizar los cambios de gráfica de manera rápida y sencilla. Contiene todos los elementos necesarios para su montaje (1 perfil de plástico y colgadores). Disponible en color blanco, negro o transparente.

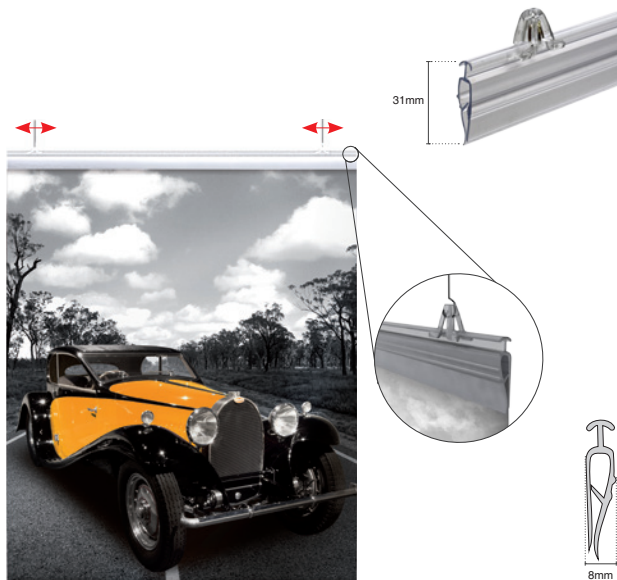

	QTY	N.W(kg)	G.W(kg)	C.B.M.	Size(mm)
Packing	12	0.52	0.72	0.029	360x160x520

10.630 clear

10.631

10.632 **500mm** x12

	QTY	N.W(kg)	G.W(kg)	C.B.M.	Size(mm)
Packing	12	1	1.2	0.035	270x160x820

10.633 clear

10.634

10.635 **800mm** x12

	QTY	N.W(kg)	G.W(kg)	C.B.M.	Size(mm)
Packing	12	1.2	1.4	0.044	270x160x1020

10.636 clear

10.637

10.638 **1000mm** x12

AluGrip

Aufhänger - Set, Klemmschienen - System "Alugrip", extra schmales Aluminiumprofil, einfacher und schneller Grafikwechsel. Set enthält alle notwendigen Bestandteile für Montage (1 Kopfschiene, Endkappen, Klemmschiene und Aufhänger). In verschiedenen Größen erhältlich.

AluGrip System Kit for graphical support through suspension. Extrafine bars. The changes of graphics can be done in a simple way. The kits contain all the needed elements for assembly (1 bar, plastic endcaps, gripper and hangers). Available in different sizes.

Barre à clips, extra-fine, pour suspension de visuels, fabriqué en aluminium et plastique. Permet le changement rapide et simple des visuels. 1barre, bouchons, gripper et anneaux inclus.

Perfil de alumínio e plástico adequado para impressões pesadas e grandes, não necessitando de ferramentas para a sua montagem. Cada kit inclui um perfil, grippers, tampas laterais e suspensores.

Kit sistema Alugrip para soporte de gráfica mediante suspensión. Barras extrafinas. Preparadas para realizar los cambios de gráficas de una forma sencilla. Los kits contienen todos los elementos necesarios para su montaje (1 barra, tapas, gripper y anillas para colgar). Disponible en varias medidas.

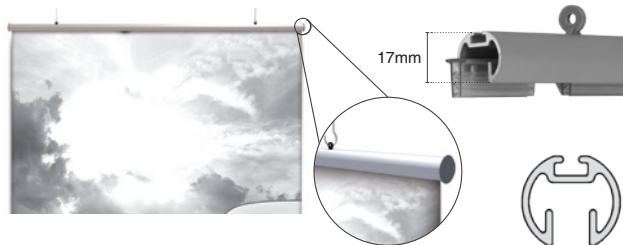

	QTY	N.W(kg)	G.W(kg)	C.B.M.	Size(mm)
Packing	4	0.31	0.5	0.0008	50x45x340

10.172 **300mm** x4

	QTY	N.W(kg)	G.W(kg)	C.B.M.	Size(mm)
Packing	4	0.51	0.7	0.0012	50x45x540

10.173 **500mm** x4

	QTY	N.W(kg)	G.W(kg)	C.B.M.	Size(mm)
Packing	4	0.7	0.85	0.0017	50x45x740

10.174 **700mm** x4

	QTY	N.W(kg)	G.W(kg)	C.B.M.	Size(mm)
Packing	4	1	1.4	0.0023	50x45x1040

10.175 **1000mm** x4

Accessories Alugrip

	QTY	N.W(kg)	G.W(kg)	C.B.M.	Size(mm)
Packing	10	0.025	0.03	0.0005	75x75x90

10.176 x10 **Gripper 50mm**

	QTY	N.W(kg)	G.W(kg)	C.B.M.	Size(mm)
Packing	10	0.007	0.008	0.0005	75x75x90

10.177 x10 **Plastic Endcaps**

	QTY	N.W(kg)	G.W(kg)	C.B.M.	Size(mm)
Packing	10	0.0045	0.0055	0.0005	75x75x90

10.178 x10 **Alugrip Hangers**

	QTY	N.W(kg)	G.W(kg)	C.B.M.	Size(mm)
Packing	10	0.006	0.01	0.00004	65x10x65

10.179 x10 **Alugrip Hangers**

AluPoster

Aufhänger - Set, Klicksystem, einfacher und schneller Grafikwechsel. Set enthält alle notwendigen Bestandteile für Montage (1 Kopfschiene, Endkappen und Aufhänger). In verschiedenen Größen verfügbar.

AluPoster system kit for graphical support through suspension and "click" system. The changes of graphics can be done in a quick and simple way. Contains all the needed elements for assembly (1 bar, plastic endcaps and hangers). Available in different sizes.

Kit système Aluposter pour la fixation d'un visuel suspendu avec le système Clic-Clac. Conçu pour un changement des visuels simple et rapide. Les kits contiennent tous les éléments nécessaires pour leur montage (1 barre, bouchons, anneaux). Disponible en différentes dimensions.

Perfil alumínio e plástico adequado para impressões pesadas e grande, não necessitando de ferramentas para a sua montagem. A imagem muda-se abrindo a parte frontal do perfil. Cada kit inclui um perfil, tampas laterais e suspensores.

Kit sistema Aluposter para soporte de gráfica mediante suspensión y sistema "click". Preparado para realizar los cambios de gráfica de manera rápida y sencilla. Contiene todos los elementos necesarios para su montaje (1 barra, tapas, colgadores). Disponible en varias medidas.

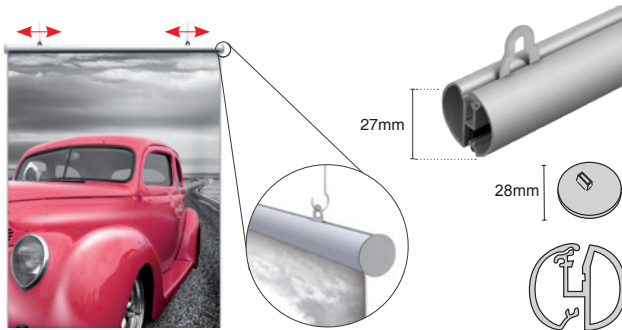

	QTY	N.W(kg)	G.W(kg)	C.B.M.	Size(mm)
Packing	4	0.4	0.6	0.0014	80x60x310

10.086 **300mm** **x4**

	QTY	N.W(kg)	G.W(kg)	C.B.M.	Size(mm)
Packing	4	0.72	0.92	0.0024	80x60x510

10.087 **500mm** **x4**

	QTY	N.W(kg)	G.W(kg)	C.B.M.	Size(mm)
Packing	4	1.12	1.32	0.0038	80x60x810

10.088 **800mm** **x4**

	QTY	N.W(kg)	G.W(kg)	C.B.M.	Size(mm)
Packing	4	1.48	1.68	0.0048	80x60x1010

10.089 **1000mm** **x4**

	QTY	N.W(kg)	G.W(kg)	C.B.M.	Size(mm)
Packing	4	1.68	1.88	0.0058	80x60x1210

10.090 **1200mm** **x4**

	QTY	N.W(kg)	G.W(kg)	C.B.M.	Size(mm)
Packing	4	2	2.2	0.0072	80x60x1510

10.091 **1500mm** **x4**

AluClip

Aufhänger - Set, Klicksystem, einfacher und schneller Grafikwechsel. Set enthält alle notwendigen Bestandteile für Montage (1 Kopfschiene, Endkappen und Aufhänger). In verschiedenen Größen verfügbar.

AluClip System Kit specially designed for graphical support through "click" system. Simple replacement of graphics. Each kit contains all the necessary elements for assembly (1 bar, plastic endcaps and hangers). Available in different sizes.

Kit système Aluclip spécialement dessiné pour la fixation de visuel avec le système Clic-Clac. La barre possède un système de charnières qui maintiennent le tissu fermement, permettant un changement des visuels facile. Les kits contiennent tous les éléments nécessaires pour le montage (1 barre, bouchons et anneaux pour l'accroche). Disponible en plusieurs dimensions.

Perfil alumínio e plástico adequado para impressões pesadas e grande, não necessitando de ferramentas para a sua montagem. A imagem muda-se abrindo a parte frontal do perfil. Cada kit inclui um perfil, tampas laterais e suspensores.

Kit sistema Aluclip, especialmente diseñado para fijación de gráficas mediante sistema "click". Fácil sustitución de gráficas. Contiene todos los elementos necesarios para su montaje (1 barra, tapas, colgadores). Disponible en varias medidas.

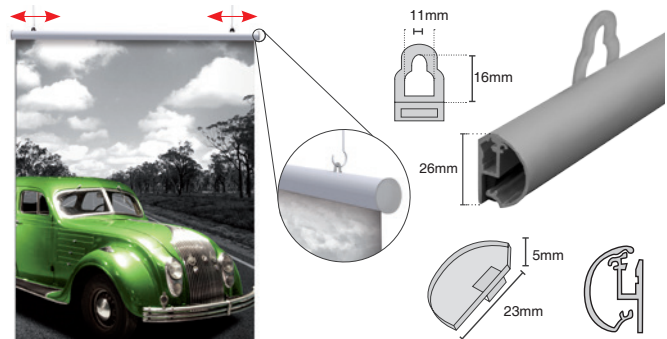

	QTY	N.W(kg)	G.W(kg)	C.B.M.	Size(mm)
Packing	4	0.35	0.50	0.0009	65x40x320

10.080 **300mm** **x4**

	QTY	N.W(kg)	G.W(kg)	C.B.M.	Size(mm)
Packing	4	0.57	0.8	0.0014	65x40x540

10.081 **500mm** **x4**

	QTY	N.W(kg)	G.W(kg)	C.B.M.	Size(mm)
Packing	4	0.9	1.2	0.0022	65x40x840

10.082 **800mm** **x4**

	QTY	N.W(kg)	G.W(kg)	C.B.M.	Size(mm)
Packing	4	1.2	1.5	0.0027	65x40x1040

10.083 **1000mm** **x4**

	QTY	N.W(kg)	G.W(kg)	C.B.M.	Size(mm)
Packing	4	1.4	1.8	0.0032	65x40x1240

10.084 **1200mm** **x4**

	QTY	N.W(kg)	G.W(kg)	C.B.M.	Size(mm)
Packing	4	1.7	2.2	0.0040	65x40x1540

10.085 **1500mm** **x4**

Accessories AluPoster / AluClip

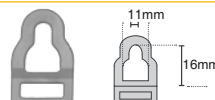
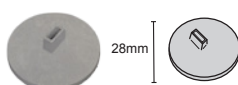

	QTY	N.W(kg)	G.W(kg)	C.B.M.	Size(mm)
Packing	1	0.009	0.02	0.00004	65x10x65

13.399 **x10** **Plastic Endcaps AluPoster**

	QTY	N.W(kg)	G.W(kg)	C.B.M.	Size(mm)
Packing	1	0.047	0.01	0.00004	65x10x65

13.400 **x10** **Ring Clip for AluPoster and AluClip**

	QTY	N.W(kg)	G.W(kg)	C.B.M.	Size(mm)
Packing	1	0.009	0.02	0.00004	65x10x65

13.398 **x10** **Plastic Endcaps Aluclip**

* 5 left - 5 right / 5 left - 5 right / 5 gauche - 5 droite / 5 Esquada - 5 direita / 5 izquierda - 5 derecha

POSTER SYSTEM

1

Alulon

 Aufhänger - Set für Grafiken aus Stoff, System „Alulon“, Schiene funktioniert durch Druckmechanismus, einfacher und schneller Grafikwechsel. Set enthält alle notwendigen Bestandteile für Montage (1 Kopfschiene, Endkappen und Aufhänger). In verschiedenen Größen erhältlich.

 Alulon System Kit specially designed for applications involving hanging canvas. The rod has a hinge system for pressure firmly holding the canvas, doing very easy its replacement. The kits contain all the needed elements for assembly (1 bar, plastic endcaps and hangers). Available in different sizes.

 Kit système Alulon spécialement destiné pour une suspension de visuels en tissu. La barre possède un système de charnières qui maintiennent le tissu fermement, permettant un changement des visuels facile. Les kits contiennent tous les éléments nécessaires pour le montage (barre, bouchons et anneaux pour l'accroche). Disponible en plusieurs dimensions.

 Perfil alumínio e plástico adequado para impressões pesadas e grande, não necessitando de ferramentas para a sua montagem. Cada kit inclui um perfil, tampas laterais e suspensores.

 Kit Sistema Alulón, especialmente diseñado para aplicaciones con lonas suspendidas. La barra tiene un sistema de bisagra por presión que sujeta la lona firmemente, haciendo su sustitución muy sencilla. Los kits contienen todos los elementos necesarios para su montaje (1 barra, tapas y anillas para colgar). Disponible en varias medidas.

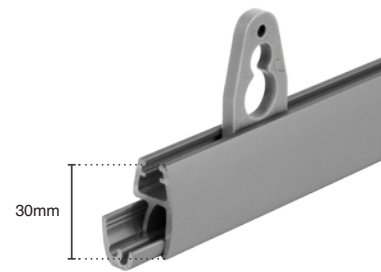



	QTY	N.W(kg)	G.W(kg)	C.B.M.	Size(mm)
Packing	4	1.2	1.4	0.0017	540x90x35
10.571		500mm		x4	

	QTY	N.W(kg)	G.W(kg)	C.B.M.	Size(mm)
Packing	4	1.8	2.1	0.0026	90x35x840
10.191		800mm		x4	

	QTY	N.W(kg)	G.W(kg)	C.B.M.	Size(mm)
Packing	4	2.2	2.6	0.0033	90x35x1040
10.572		1000mm		x4	

	QTY	N.W(kg)	G.W(kg)	C.B.M.	Size(mm)
Packing	4	2.7	3	0.0039	90x35x1240
10.193		1200mm		x4	

	QTY	N.W(kg)	G.W(kg)	C.B.M.	Size(mm)
Packing	4	3.4	3.8	0.0049	90x35x1540
10.194		1500mm		x4	

	QTY	N.W(kg)	G.W(kg)	C.B.M.	Size(mm)
Packing	4	6.5	7.4	0.0123	90x45x3025
10.195		3000mm		x4	

Accessories Alulon



	QTY	N.W(kg)	G.W(kg)	C.B.M.	Size(mm)
Packing	1	0.009	0.02	0.00004	65x10x65
10.196		x10	Plastic Endcaps		

Ring Clip

 Kunststoff-Aufhänger für verschiedene Aluminiumprofile.

 Plastic hanger for different aluminium profiles.

 Crochets en plastique pour profils en aluminium.

 Suspensor de plástico para perfis de alumínio.

 Colgador de plástico para perfiles de aluminio.

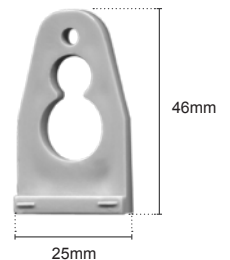

	QTY	N.W(kg)	G.W(kg)	C.B.M.	Size(mm)
Packing	1	0.047	0.01	0.00004	65x10x65
10.197		x10	Ring Clip		

BICYCLES STAND

Carlow

Fahrradständer aus Stahl. Aufgrund verzinkter Oberfläche witterungsbeständig und Korrosionsgeschützt. Material: Stahl, verzinkt.

Support made of steel for outdoor bicycle placement. Galvanized finishing so is weatherproof and resistant to corrosion. Galvanized steel.

Support fabriqué en acier pour le stationnement de vélos, en extérieur.

Porta-bicicletas robusto fabricado em aço com acabamento galvanizado. O seu design permite uni-los uns aos outros e ao solo. O seu acabamento galvanizado torna este suporte impermeável e resistente à corrosão.

Soporte realizado en acero para colocación de bicicletas en exterior.

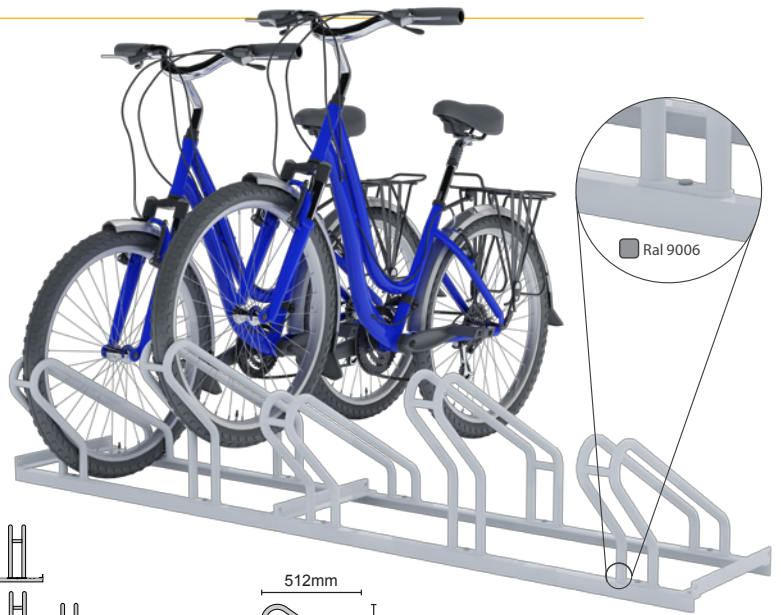
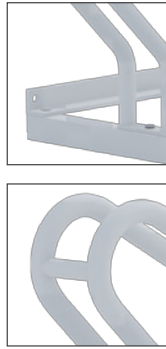

Ral 9006

10.705	700mm	2 Places	
10.706	1050mm	3 Places	
10.762	1750mm	5 Places	
10.782	2100mm	6 Places	
10.933	2450mm	7 Places	

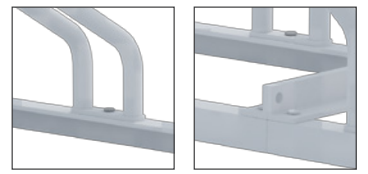
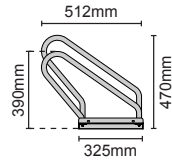

Wexford

Fahrradständer aus Stahl und zwei Rahmen. Aufgrund verzinkter Oberfläche witterungsbeständig und Korrosionsgeschützt. Material: Stahl, verzinkt.

Galvanized finishing so is weatherproof and resistant to corrosion. Includes double-sided frame. Galvanized steel.

Support fabriqué en acier pour le stationnement de vélos. Cadre double face inclus.

Porta-bicicletas robusto fabricado em aço com acabamento galvanizado. O seu design permite uni-los uns aos outros e ao solo. O seu acabamento galvanizado torna este suporte impermeável e resistente à corrosão.

Soporte realizado en acero para colocación de bicicletas. Incluye marco doble cara.

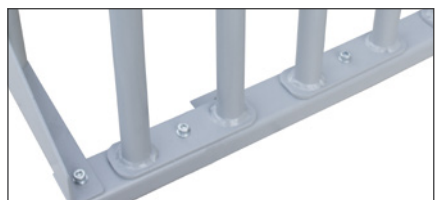
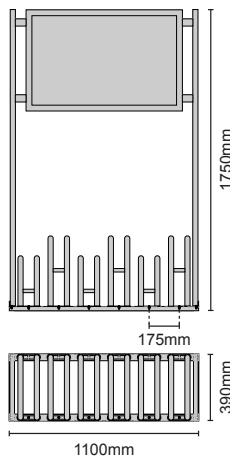
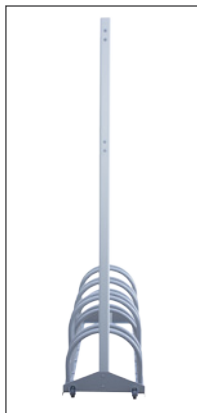

Ral 9006

10.809	A1		
--------	----	--	--

1

Table Display

Display-Turm aus PET mit Schütte.

Exhibitor done in PET for the exhibition and sale of articles. Includes a dispensing "box". Easy and fast to assembly.

Présentoir fabriqué en PET pour l'exposition et vente de produits. Distributeur inclus.

Expositor de plástico fácil e rápido de montar.

Expositor realizado en PET para la exposición y venta de artículos. Incluye una "boca" dispensadora.

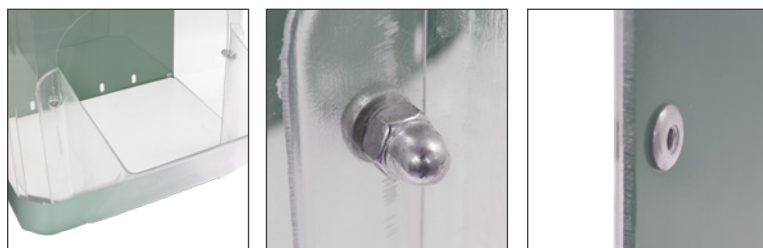

	QTY	N.W(kg)	G.W(kg)	C.B.M.	Size(mm)
Packing	1	2.5	3.6	0.058	300x210x920

10.475 **285x190x900mm**

Wall Display

Display-Turm aus PET mit Schütte.

Exhibitor done in PET for the exhibition and sale of articles. Includes a dispensing "box".

Présentoir fabriqué en PET pour l'exposition et vente de produits. Distributeur inclus.

Expositor de chão fabricado em plástico. Permite uma montagem fácil e rápida.

Expositor realizado en PET para la exposición y venta de artículos. Incluye una "boca" dispensadora.

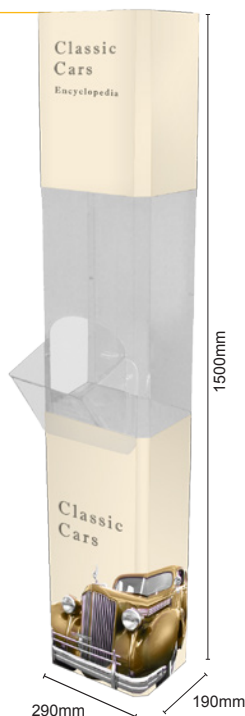

	QTY	N.W(kg)	G.W(kg)	C.B.M.	Size(mm)
Packing	1	3.7	5.46	0.1238	335x240x1540

10.476 **290x190x1500mm**

Floor Display

Display-Turm aus PET mit Schütte.

Exhibitor done in PET for the exhibition and sale of articles. Includes two dispensing "boxes". Easy and fast to assembly.

Présentoir fabriqué en PET pour l'exposition et vente de produits. Deux distributeurs inclus.

Expositor de chão fabricado em plástico. Permite uma montagem fácil e rápida.

Expositor realizado en PET para la exposición y venta de artículos. Incluye dos "bocas" dispensadoras.

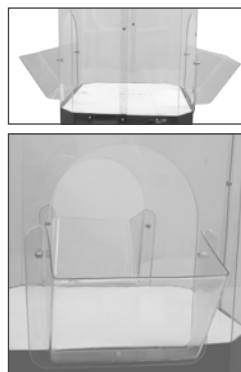

	QTY	N.W(kg)	G.W(kg)	C.B.M.	Size(mm)
Packing	1	7.35	8.2	0.27	450x400x1520

10.477 **420x385x1500mm**

“Easy”

Verkaufspräsentier aus Kunststoff, besteht aus 4 Böden und den dazugehörigen Seitenteilen, Bodenplatte aus Kunststoff mit Rädern, Kartonaufsatz für Grafik.

Easy display. Injected plastic exhibitor made for exposure and implementation of products. Includes 4 shelves, with transparent side supports. Incorporates a plastic base with wheels to place the lower die poster and white cardboard for the bottom graph. Carton for top upper part included. No tools required for assembly.

Présentoir fabriqué en plastique injecté pour l'exposition et l'implantation des produits. Composé de 4 étagères avec des cotés transparents. Base plastique avec roulettes incluses, qui soutient la partie inférieure de la structure. Carton blanc pour l'impression du visuel inférieur et support pour visuel supérieur inclus.

Expositor de plástico injectado com quatro prateleiras que se empilham através de barras laterais transparentes. Contém todos os elementos necessários para a sua montagem. Inclui cartão para impressão inferior e superior.

Expositor realizado en plástico inyectado para la exposición e implantación de productos. Se compone de 4 estanterías, con sus respectivos soportes laterales transparentes. Incluye una base plástica con ruedas para colocar el cartel inferior y cartón troquelado en blanco para la gráfica inferior. Cartón para gráfica superior incluida.

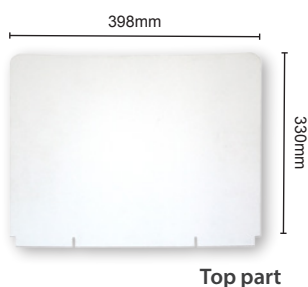

	QTY	N.W(kg)	G.W(kg)	C.B.M.	Size(mm)
Packing	1	4	4.8	0.0572	520x155x710

10.478 **305x405x1620mm**

Display Shelf

Verkaufsständer aus Kunststoff, einfacher und schneller Auf- und Abbau, Höhe 1480mm.

Display with fully removable rectangular shape for product exhibition. Available in white, red, blue or black. No tools required for assembly. Plastic. Height: 1480mm.

Présentoir rectangulaire et démontable pour l'exposition de produits. Matière: plastique. Hauteur: 1480mm.

Expositor vermelho, branco, azul ou preto com prateleiras rectangulares que se empilham em barras transparentes. Não necessita de ferramentas para a montagem.

Expositor con forma rectangular totalmente desmontable, para exhibición de producto. Material plástico. Altura: 1480mm.



	QTY	N.W(kg)	G.Wv(kg)	C.B.M.	Size(mm)
Packing	1	8	8.45	0.073	400x290x630

10.384

10.386

10.387

10.388 **617x400x1480mm**

Promo Shop







 Flexible Display-Säule aus Kunststoff mit Schütte, einfache und schnelle Montage. Kunststoffschrauben und Verbindungsstreifen entsprechend des gewählten Display-Modells.

 Exhibitor made of injected plastic, for the exhibition and introduction of new items. Fast and easy to assemble. The plastic screws and assembling pieces for the billboard can be interchangeable between all display units, depending on the model.

 Présentoir en plastique injecté pour l'exposition et l'implantation de produits. Montage simple et rapide. Les vis en plastique et les pièces du support des visuels sont fournies selon le modèle.

 Expositor em plástico injectado para promoção e implantação de artigos. Montagem fácil e simples. Contém os parafusos de plástico e as peças de fixação necessárias para que a impressão possa ser colocada em qualquer dos módulos, dependendo do modelo.

 Expositor realizado en plástico injectado para la exposición e implantación de productos. Montaje sencillo y rápido. Los tornillos de plástico y piezas de sujeción de la cartelería se suministran con todos los displays, según modelos.

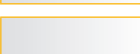
10.108	Promo Shop 1/2	
10.109	Promo Shop - 1	
10.102	Promo Shop - 2	
10.103	Promo Shop - 3	
10.104	Promo Shop - 4	
10.105	Promo Shop - 5	
10.106	Promo Shop - 6	

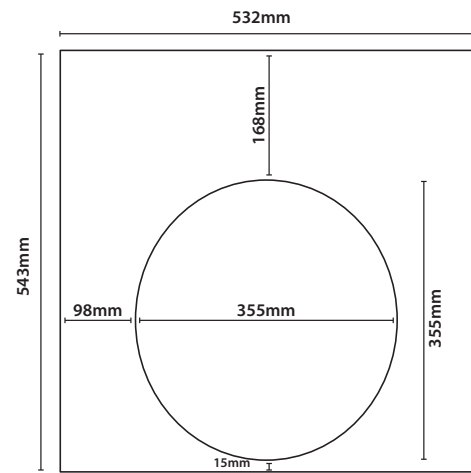

* Druck / Printing / Impression / Impressão / Impresión.

Models:



Promo Shop 1/2
10.108

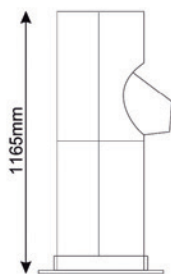

Promo Shop - 1
10.109

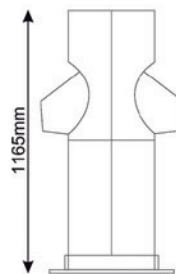

Promo Shop - 2
10.102

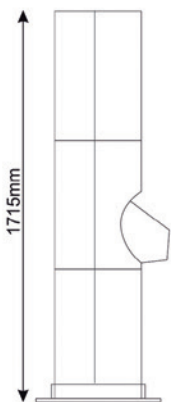

Promo Shop - 3
10.103

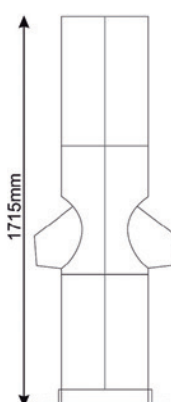

Promo Shop - 4
10.104

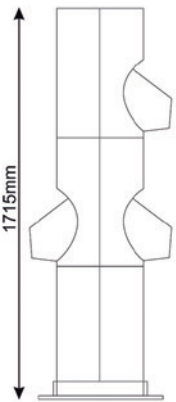

Promo Shop - 5
10.105

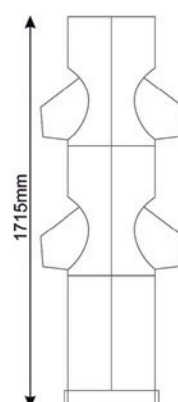

Promo Shop - 6
10.106

Promo Shop

 Befestigung der Verbindungsstreifen an den Displayhälften. (siehe Abbildung 3).

- Zusammenfügen der Teile 1 und 2.
- Nach Wunsch mit Trennwand.
- Einfügen der Bodenplatte.
- Einsetzen der Schrauben in die vorgefertigten Löcher.
- Grafik auf Säulenfuß platzieren.
- Zusammenfügen der einzelnen Module.
- Festziehen der Schrauben mittels Muttern.

 Setup:

- Place the pieces that will hold the graphic in their place, just like in picture (3).
- Join the pieces of part 1 and 2 of the exhibitor.
- If you want to place the vertical divider, join parts 1 and 2, then the exhibitor is being divided into two parts.
- Place the round piece (disk) on the bottom of the exhibitor.
- Once the last two steps have been performed, place the screws through the holes.
- Place the graphic on its correspondent place.
- Assemble the different modules.
- Tighten the screws with the nuts.

 Montage :

- Placer les pièces de fixation du visuel comme indiqué sur l'image 3.
- Unir les parties 1 et 2 du présentoir.
- Si vous désirez un séparateur vertical, placé-le lorsque vous unirez les parties 1 et 2, vous obtiendrez ainsi un présentoir divisé en deux parties.
- Emboîter le disque séparateur au fond du présentoir.
- Une fois les deux étapes antérieures réalisées, mettre les vis dans chaque trou.
- Placer le visuel.
- Monter les différents modules.
- Serrer les vis avec les écrous.

 Montagem:

- Colocar as peças de fixação na impressão de acordo com a imagem 3.
- Unir as partes 1 e 2 do expositor.
- Se desejar o separador vertical, terá de colocá-lo ao unir as partes 1 e 2, ficando o expositor dividido ao meio.
- Encaixar o disco separador no fundo do expositor.
- Introduzir os parafusos de forma a que atravessassem todos os orifícios.
- Colocar as impressões.
- Montar os diferentes módulos.
- Apertar os parafusos com as respectivas porcas.

 Montaje:

- Colocar las piezas de sujeción de cartelería, tal y como en la fotografía (3).
- Unir las partes 1 y 2 del expositor.
- Si desea separador vertical colocar al unir las partes 1 y 2, quedando entonces el expositor dividido en dos partes.
- Encajar el disco separador en el fondo del expositor.
- Una vez realizados los dos pasos anteriores colocar los tornillos, atravesando todos los agujeros.
- Colocar las gráficas.
- Montar los distintos módulos.
- Apretar los tornillos con las tuercas.

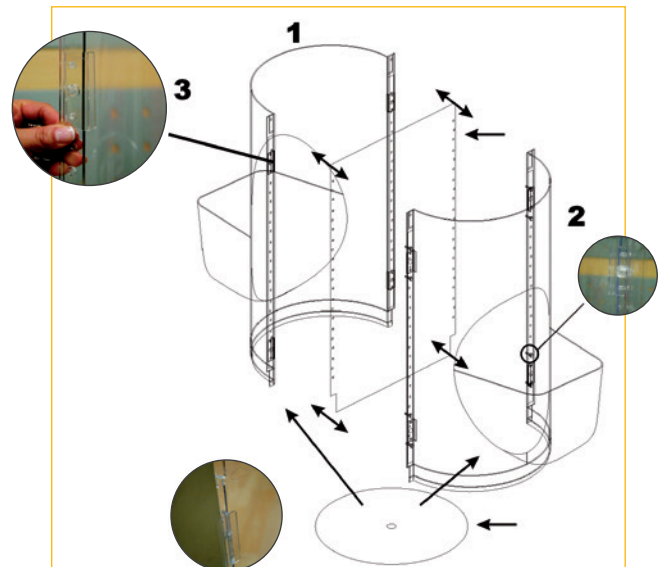
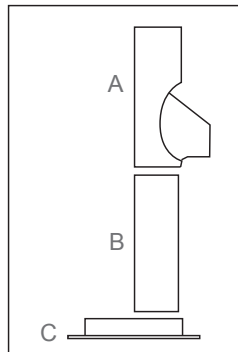

	QTY	N.W (kg)
Packing	1	1.1

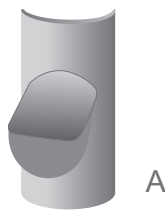

A

	QTY	N.W (kg)
Packing	1	1

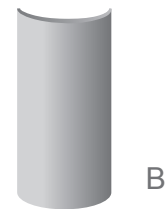

B

	QTY	N.W (kg)
Packing	1	0.5

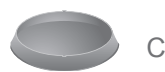

C

1

Promo Brand

- Aussteller aus Kunststoff mit Schütten. Schnell und einfach zu montieren. Kunststoff.
- Exhibitor made of plastic, for the display and introduction of products. Fast and easy to assemble.
- Présentoir en plastique pour l'exposition et vente du produit. Facile et rapide à monter.
- Expositor em plástico para promoção e implantação de artigos. Montagem fácil e simples.
- Expositor de plástico, para la implantación de productos y exposición. Fácil y rápido de montar.

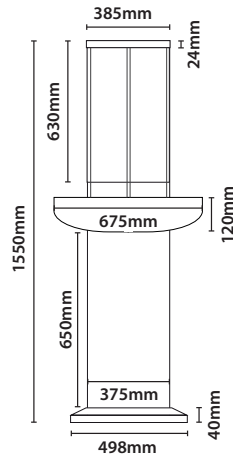

10.429 1244x700mm

* Druck / Printing / Impression / Impressão / Impresión.

Promo Cash

- Aussteller aus Kunststoff mit Schütten. Schnell und einfach zu montieren. Kunststoff.
- Exhibitor made of plastic, for the display and introduction of products. Fast and easy to assemble.
- Présentoir en plastique pour l'exposition et vente du produit. Facile et rapide à monter.
- Expositor em plástico para promoção e implantação de artigos. Montagem fácil e simples.
- Expositor de plástico, para la implantación de productos y exposición. Fácil y rápido de montar.

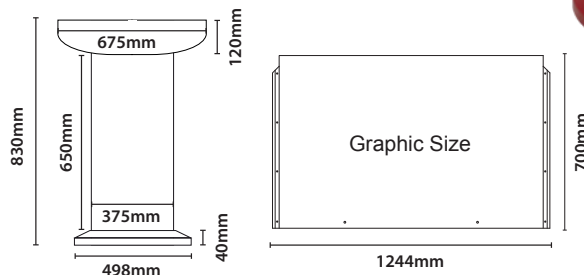



13.468 1244x700mm

* Druck / Printing / Impression / Impressão / Impresión.

Promo Store

 Aussteller aus Kunststoff mit Schütten. Schnell und einfach zu montieren. Material: Kunststoff.

 Exhibitor made of plastic, for the display and introduction of products. Fast and easy to assemble.

 Présentoir en plastique pour l'exposition et l'implantation de produits. Montage simple et rapide.

 Expositor em plástico para promoção e implantação de artigos. Montagem fácil e simples.

 Expositor de plástico, para la implantación de productos y exposición. Fácil y rápido de montar.

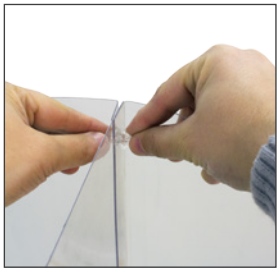
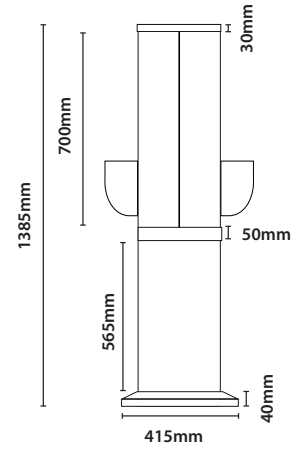
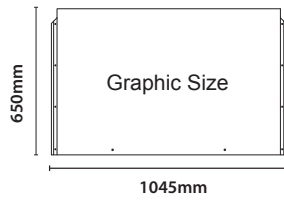

	QTY	N.W(kg)	G.Wv(kg)	C.B.M.	Size(mm)
Packing	1	2.58	3.93	0.1762	450x440x880

10.110

1045x650mm

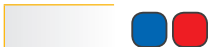

* Druck / Printing / Impression / Impressão / Impresión.

TURNTABLES

1



Turntable

Drehplatte, Farbe: Weiß.
Kunststoffkragen, Durchmesser: 130mm.
Belastbarkeit: ± 3 kg Material: Stahl,
Kunststoffteile.

Rotary engine in white colour.
Plastic Flange. Diameter: 130 mm.
Load capacity: ± 3 Kg.

Moteur de couleur blanche avec
plateau tournant. Diamètre de 130mm.
Poids supporté : +/- 3kg
Fabriqué en plastique et métal.

Motor giratório de cor branca com
flange de plástico. Diâmetro: 130mm.
Capacidade de carga: aprox. 3kg. Plástico.

Motor giratorio. Color blanco. Flange
de plástico. Diámetro: 130mm. Capacidad
de carga: aprox. 3kg. Plástico.



CAPACITY
± 3 kg



	QTY	N.W(kg)	G.W(kg)	C.B.M.	Size(mm)
Uni.	1	0.40	0.50	0.0025	150x70x240

10.518 **Ø 130x57mm**

Turntable

Drehplatte, Farbe: Weiß.
Kunststoffkragen, Durchmesser: 200mm.
Belastbarkeit: ± 20 kg Material: Stahl,
Kunststoffteile.

Rotary engine in white colour.
Plastic Flange. Diameter: 200 mm.
Load capacity: ± 20 Kg.

Moteur de couleur blanche avec
plateau tournant. Diamètre de 200mm.
Poids supporté : +/- 20kg
Fabriqué en plastique et métal.

Motor giratório de cor branca com flange
de plástico. Diâmetro: 200mm.
Capacidade de carga: aprox. 20kg. Plástico.

Motor giratorio. Color blanco. Flange
de plástico. Diámetro: 200mm. Capacidad
de carga: aprox. 20kg. Plástico.



CAPACITY
± 20 kg



	QTY	N.W(kg)	G.W(kg)	C.B.M.	Size(mm)
Uni.	1	0.75	0.90	0.0048	225x75x285

10.986 **Ø 200x60mm**

Turntable

Drehplatte, Farbe: Weiß.
Kunststoffkragen, Durchmesser: 410mm.
Belastbarkeit: ± 20 kg Material: Stahl,
Kunststoffteile.

Rotary engine in white colour.
Plastic Flange. Diameter: 410 mm.
Load capacity: ± 20 Kg. Plastic and metal.

Moteur de couleur blanche avec
plateau tournant. Diamètre de 410mm.
Poids supporté : +/- 20kg
Fabriqué en plastique et métal.

Motor giratório de cor branca com
flange de plástico. Diâmetro: 410mm.
Capacidade de carga: aprox. 20kg. Plástico.

Motor giratorio. Color blanco. Flange
de plástico. Diámetro: 410mm. Capacidad
de carga: aprox. 20kg. Plástico y metal.



CAPACITY
± 20 kg



	QTY	N.W(kg)	G.W(kg)	C.B.M.	Size(mm)
Uni.	1	1.90	2.15	0.015	420x90x420

10.987 **Ø 410x80mm**

Solar Turning Display

Solarbetriebener Pendelfuß für Grafiken. Tragkraft ca. 5g.

Solar turning display. Load capacity: ± 5g. Material: Plastic.

Moteur à l'énergie solaire pour l'exposition pendulaire de visuels. Poids supporté : +/- 5g.

Motor pendular de plástico que funciona com luz solar. Capacidade de carga: aprox. 5g.

Motor de exhibición pendular para gráfica. Peso de carga aprox: 5 gramos. Funciona con energía solar.



	QTY	N.W(kg)	G.W(kg)	C.B.M.	Size(mm)
Uni.	1	0.04	0.05	0.0002	55x30x105

10.358 **100x50x30mm**

Turntable

Mechanischer Drehfuß für Produktpräsentationen. 360° Drehung. Max. Gewicht 200g. 1 Batterie AA (nicht inkl).

Turntable. Colour: Silver. Plastic flange. Diameter: 85mm. Load capacity: ± 200g. Works with one AA battery (not included). Material: Steel, plastic parts.

Moteur giratoire de 360° pour l'exhibition des produits. Poids supporté : +/- 0.2 kg. Il fonctionne avec une pile AA (non inclus).

Motor giratório de 360°. Cor: Prateado Flange de plástico. Diâmetro: 85mm. Capacidade de carga: aprox. 200g. Funciona com uma pilha AA (não incluída). Material: Aço e plástico.

Motor para exhibición de producto en giro de 360°. Peso de carga aprox: 200 gramos. Funciona con 1 pila AA (no incluída).



	QTY	N.W(kg)	G.W(kg)	C.B.M.	Size(mm)
Uni.	1	0.12	0.15	0.0001	95x89x125

10.406 **Ø 85x45mm**

Turntable

Drehplatte, Drehwinkel 360°. Verfügt über 4 innenliegende LEDs.

LED turntable display stand. Includes 4 leds. Battery and electric operated. Plugged into the power supply, run both the turntable and led lights, but using a battery like power supply, only the function of the LED light is allowed.

Moteur giratoire avec 4 Leds, fabriqué en acier et plastique. Fonctionne sur secteur ou avec des piles. Secteur : Fonction rotation et Leds. Piles : Seulement fonction Leds. Transformateur inclus.

Motor giratório (360°) de plástico e metal. Inclui 4 leds. Possibilidade de utilizar pilhas ou transformador elétrico. Capacidade de carga: aprox. 2kg.

Motor giro de 360°. Dispone de 4 leds. Enchufado a la corriente eléctrica el motor gira y la función LED funciona, si solo se utiliza con pilas solo funciona el LED, el motor no gira. Incluye transformador para corriente.



CAPACITY
± 2 kg



	QTY	N.W(kg)	G.W(kg)	C.B.M.	Size(mm)
Uni.	1	0.3	0.35	0.002	125x75x190

10.407 **Ø 80x45mm**



CAPACITY
± 2.5 kg



	QTY	N.W(kg)	G.W(kg)	C.B.M.	Size(mm)
Uni.	1	0.40	0.45	0.0013	127x55x197

10.456 **Ø 107x45mm**



Battery Turning Display

Pendelmotor für Grafiken. Tragkraft ca. 14g. Benötigt 2 Batterien AA (nicht inklusive).

Battery turning display. Load capacity: ± 14g. Works with 2 AA batteries (not included). Plastic.

Moteur pour l'exposition pendulaire de visuels. Poids supporté : +/- 14g. Fonctionne avec des piles AA (non fournies).

Motor pendular de plástico. Capacidade de carga: aprox.14g. Funciona com pilhas AA (não incluídas).

Motor de exhibición pendular para gráfica. Peso de carga aprox: 14 gramos. Funciona con dos pilas AA (no incluídas).



	QTY	N.W(kg)	G.W(kg)	C.B.M.	Size(mm)
Uni.	1	0.11	0.14	0.0006	75x50x165

10.063 **160x70x43mm**

Turntable

Solarbetriebener Drehfuß für Produktpräsentationen, Drehwinkel 360°. Tragkraft ca. 200g.

Solar turning display. Load capacity: ± 200g. Plastic.

Moteur giratoire 360°. Poids supporté : +/- 200g. Fonction par énergie solaire.

Motor giratório (360°) de plástico que funciona a luz solar. Capacidade de carga: aprox.200g.

Motor giro de 360°. Peso de carga aprox: 200g. Funciona con energia solar.



	QTY	N.W(kg)	G.W(kg)	C.B.M.	Size(mm)
Uni.	1	0.08	0.10	0.0004	85x45x115

10.064 **112x80x43mm**

LEDS

LED Modul, wasserdicht, hervorragend geeignet zur Beleuchtung von Außeninstallationen. Anwendungsbereiche: Lichtfluter, Beleuchtung von Profilbuchstaben, Signalanlagen, Innenraumgestaltung.

Waterproof Led, waterproof for channel letters lighting and other applications due to its low voltage and high brightness. Suitable for outdoor use. Uses: lighting channel letters, interior decoration, signage, signs of light filter. With double-sided adhesive.

Leds étanches. Utilisation extérieure ou intérieure. Applications: création de lettres lumineuses, décoration lumineuse d'intérieur, éclairage de façade et de panneaux d'information. Adhésif double face inclus.

Led à impermeável com 3 diodos por cada módulo. Utilização: letras corpóreas iluminadas, retroiluminação, iluminação de expositores, decoração luminosa de interiores, fachadas, sinalética e substituição de néon. Fita dupla face incluída.

Led estanco, resistente al agua, para la iluminación de letras corpóreas y otras aplicaciones gracias a su bajo voltaje y alta luminosidad. Válido para exterior. Usos: iluminación de letras corpóreas, decoración interior, señalética, rotulos de luz filtrante. Con adhesivo de doble cara.

Antilia



*With adhesive double-sided.

13.222	□	6500K	16 Lm
13.223	■	6190-6350K	3.5 Lm
13.224	■	5120-5280K	9 Lm
13.225	■	4630-4750K	2.8 Lm
13.226	■	5840-5950K	3.2 Lm

Input-Voltage.	12V
Power.	0.24W
Viewing angle Led.	140°
Units led.	3
Type.	SMD 3528
IP Grade.	IP 66
Working Temp.	-40° / 60°
Aprox. Life.	50.000H

x20

Boötes



*With adhesive double-sided.

13.227	□	6500K	14 Lm
13.228	■	6190-6350K	7 Lm
13.229	■	5120-5280K	13 Lm
13.230	■	4630-4750K	7 Lm
13.231	■	5840-5950K	7 Lm

Input-Voltage.	12V
Power.	0.24W
Viewing angle Led.	140°
Units led.	1
Type.	SMD 5050
IP Grade.	IP 66
Working Temp.	-40° / 60°
Aprox. Life.	50.000H

x20

Corvus



*With double-sided adhesive.

13.232	□	6500K	28 Lm
13.233	■	6190-6350K	11 Lm
13.234	■	5120-5280K	15 Lm
13.235	■	4630-4750K	10 Lm
13.236	■	5840-5950K	10 Lm

Input-Voltage.	12V
Power.	0.48W
Viewing angle Led.	140°
Units led.	2
Type.	SMD 5050
IP Grade.	IP 66
Working Temp.	-40° / 60°
Aprox. Life.	50.000H

x20

Deneb



*With double-sided adhesive.

13.237	□	6500K	38 Lm
13.238	■	6190-6350K	16 Lm
13.239	■	5120-5280K	20 Lm
13.240	■	4630-4750K	15 Lm
13.241	■	5840-5950K	15 Lm

Input-Voltage.	12V
Power.	0.72W
Viewing angle Led.	140°
Units led.	3
Type.	SMD 5050
IP Grade.	IP 66
Working Temp.	-40° / 60°
Aprox. Life.	50.000H

x20

Eridanus

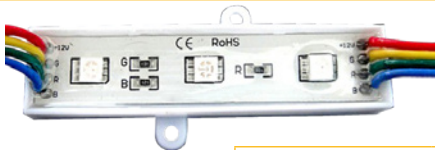

*With double-sided adhesive.

13.242	■	RGB	
--------	---	-----	--

Input-Voltage.	12V
Power.	0.72W
Viewing angle Led.	140°
Units led.	3
Type.	SMD 5050
IP Grade.	IP 66
Working Temp.	-40° / 60°
Aprox. Life.	50.000H

x20

Lepus



*With double-sided adhesive.

13.245	■	RGB	
--------	---	-----	--

Input-Voltage.	12V
Power.	0.72W
Viewing angle Led.	90°
Units led.	9
Type.	3R3G3B
IP Grade.	IP 66
Working Temp.	-40° / 60°
Aprox. Life.	50.000H

x20

Orionis

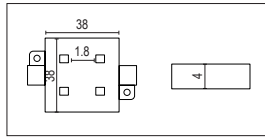

*With double-sided adhesive.

13.248	<input type="checkbox"/>	6500K	40 Lm
13.249	<input type="checkbox"/>	6190-6350K	21 Lm
13.250	<input type="checkbox"/>	5120-5280K	28 Lm
13.251	<input type="checkbox"/>	4630-4750K	20 Lm
13.252	<input type="checkbox"/>	5840-5950K	20 Lm

Input-Voltage.	12V
Power.	0.96W
Viewing angle Led.	140°
Units led.	4
Type.	SMD 5050
IP Grade.	IP 66
Working Temp.	-40° / 60°
Aprox. Life.	50.000H

x60

Perseus

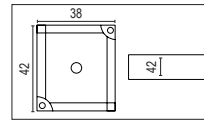

*With double-sided adhesive.

13.253	<input type="checkbox"/>	6500K	110 Lm
13.254	<input type="checkbox"/>	6190-6350K	40 Lm
13.255	<input type="checkbox"/>	5120-5280K	65 Lm
13.256	<input type="checkbox"/>	4630-4750K	25 Lm
13.257	<input type="checkbox"/>	5840-5950K	40 Lm

Input-Voltage.	12V
Power.	1W
Viewing angle Led.	140°
Units led.	1
Type.	1W
IP Grade.	IP 66
Working Temp.	-40° / 60°
Aprox. Life.	50.000H

x30

Sagitta

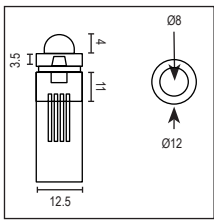

*With double-sided adhesive.

13.258	<input type="checkbox"/>	RGB	x50
---------------	--------------------------	-----	-----

Input-Voltage.	5V
Power.	0.3W
Viewing angle Led.	120°
Units led.	1
Type.	8mm RGB LED
IP Grade.	IP 66
Working Temp.	-40° / 60°
Aprox. Life.	50.000H

Serpens

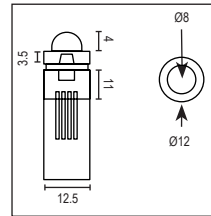

*With double-sided adhesive.

13.259	<input type="checkbox"/>	
13.260	<input type="checkbox"/>	
13.261	<input type="checkbox"/>	
13.262	<input type="checkbox"/>	
13.263	<input type="checkbox"/>	

Input-Voltage.	5V
Power.	0.1W
Viewing angle Led.	90°
Units led.	1
Type.	8mm LED
IP Grade.	IP 66
Working Temp.	-40° / 60°
Aprox. Life.	50.000H

x50

Hydra

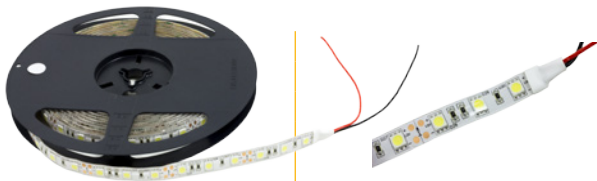

Input-Voltage.	12V
Power.	300 LEDs 72W
Viewing angle Led.	120°
Type.	SMD 5050
IP Grade.	IP 65
Working Temp.	120°
Aprox. Life.	50.000H
Colour Temperature	6500K



*With double-sided adhesive.

58.071	<input type="checkbox"/>	300 LEDs	White	Roll 5m.
---------------	--------------------------	----------	-------	----------

*Connector RGB

13.247	<input type="checkbox"/>	100mm	RGB
---------------	--------------------------	-------	-----

*Connector monochrome

13.280	<input type="checkbox"/>	100mm
---------------	--------------------------	-------

Orion



*With double-sided adhesive.

Input-Voltage.	12V
Power.	300 LEDs 72W
Viewing angle Led.	120°
Type.	SMD 5050
IP Grade.	IP 33
Working Temp.	120°
Aprox. Life.	50.000H
Colour Temperature	6500K



58.068	<input type="checkbox"/>	300 LEDs	White	Roll 5m.
---------------	--------------------------	----------	-------	----------



58.069	<input type="checkbox"/>	300 LEDs	RGB	Roll 5m.
---------------	--------------------------	----------	-----	----------

Kamal

RGB LED-Controller zur individuellen und einfachen Einstellung von Farbwechsel und Farbsequenzen. Geeignet für LED-Streifen sowie für einzelne Module. 256 Helligkeitsstufen.

RF controller adopts the advanced micro control unit, it is used for controlling a variety of lamp whose source of light is LED. For instance, point source of light, flexible light strip, wall washer lamp, etc.

Séquenceur qui permet de programmer les LEDs type RGB afin de changer de couleur et créer des séquences de changement de façon intuitive et facile. Valable pour les LEDs en bandes ou modules. 256 niveaux de brillance.

Alternador que utiliza uma micro unidade de controlo para regular uma série de luzes cuja fonte luminosa é o LED. Por exemplo, pontos de luz, tiras luminosas, banho de luz, etc.

Secuenciador que permite programar LEDs tipo RGB con el fin de cambiar de color o crear secuencias de cambio de forma intuitiva y sencilla. Válido para LEDs en tiras o módulos. 256 niveles de brillo.

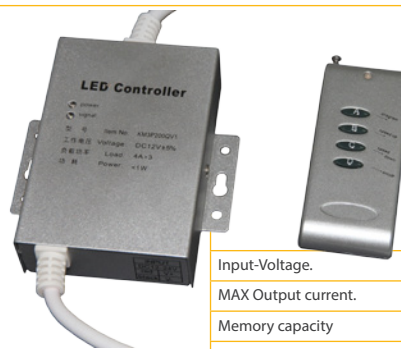

Input-Voltage.	12V
MAX Output current.	4-6A
Memory capacity	16 Kb
Control Distance.	30-50 m
Dimensions (LxWxH)	89x26x95mm
Weight.	250g



13.281

Kamal

Convers

Pegasus

Input-Voltage: 110-250V	Output-Voltage: 12V
Power: 15W	Output current: 1.25A
Installation: Waterproof IP66	Cooling: Free air convection
Dimensions (LxWxH): 30x20x180mm	Weight: 0.18Kg



13.264



Grus

Input-Voltage: 170-250V	Output-Voltage: 12V
Power: 30W	Output current: 2.5A
Installation: Waterproof IP66	Cooling: Free air convection
Dimensions (LxWxH): 30x20x220mm	Weight: 0.25kg



13.265



Centaurus

Input-Voltage: 170-250V	Output-Voltage: 12V
Power: 60W	Output current: 5A
Installation: Waterproof IP66	Cooling: Free air convection
Dimensions (LxWxH): 67x50x180mm	Weight: 0.8kg



13.266



Cassiopea

Input-Voltage: 170-250V	Output-Voltage: 12V
Power: 100W	Output current: 8.3 A
Installation: Waterproof IP66	Cooling: Free air convection
Dimensions (LxWxH): 67x50x243mm	Weight: 0.9kg



13.267



Ursa

Input-Voltage: 110-250V	Output-Voltage: 12V
Power: 150W	Output current: 12.5 A
Installation: Waterproof IP66	Cooling: Free air convection
Dimensions (LxWxH): 134x70x211mm	Weight: 2.36kg



13.268



Volans

Input-Voltage: 170-250V	Output-Voltage: 5V DC
Power: 30W	Output current: 5 A
Installation: Waterproof IP66	Cooling: Free air convection
Dimensions (LxWxH): 30x20x205mm	Weight: 0.8kg



13.271



Lynx

Input-Voltage: 170-250V	Output-Voltage: 5V DC
Power: 60W	Output current: 5 A
Installation: Waterproof IP66	Cooling: Free air convection
Dimensions (LxWxH): 67x50x180mm	Weight: 0.8kg



13.272



Relationship - LEDs / Power supply

		Power supply						
		Pegasus	Grus	Centaurus	Cassiopeia	Ursa	Volans	Lynx
LEDs	Antilia	±50	±100	±200	±333	±500		
	Boötes	±50	±100	±200	±333	±500		
	Corvus	±25	±50	±100	±167	±250		
	Deneb	±17	±34	±68	±111	±167		
	Eridanus	±17	±34	±68	±111	±167		
	Lepus	±17	±34	±68	±111	±167		
	Orionis	±13	±26	±52	±83	±125		
	Perseus	±12	±24	±48	±80	±120		
	Sagitta						±80	±160
	Serpens						±240	±480

*LEDs units. / Unidades de LEDs / Unidades de LEDs.

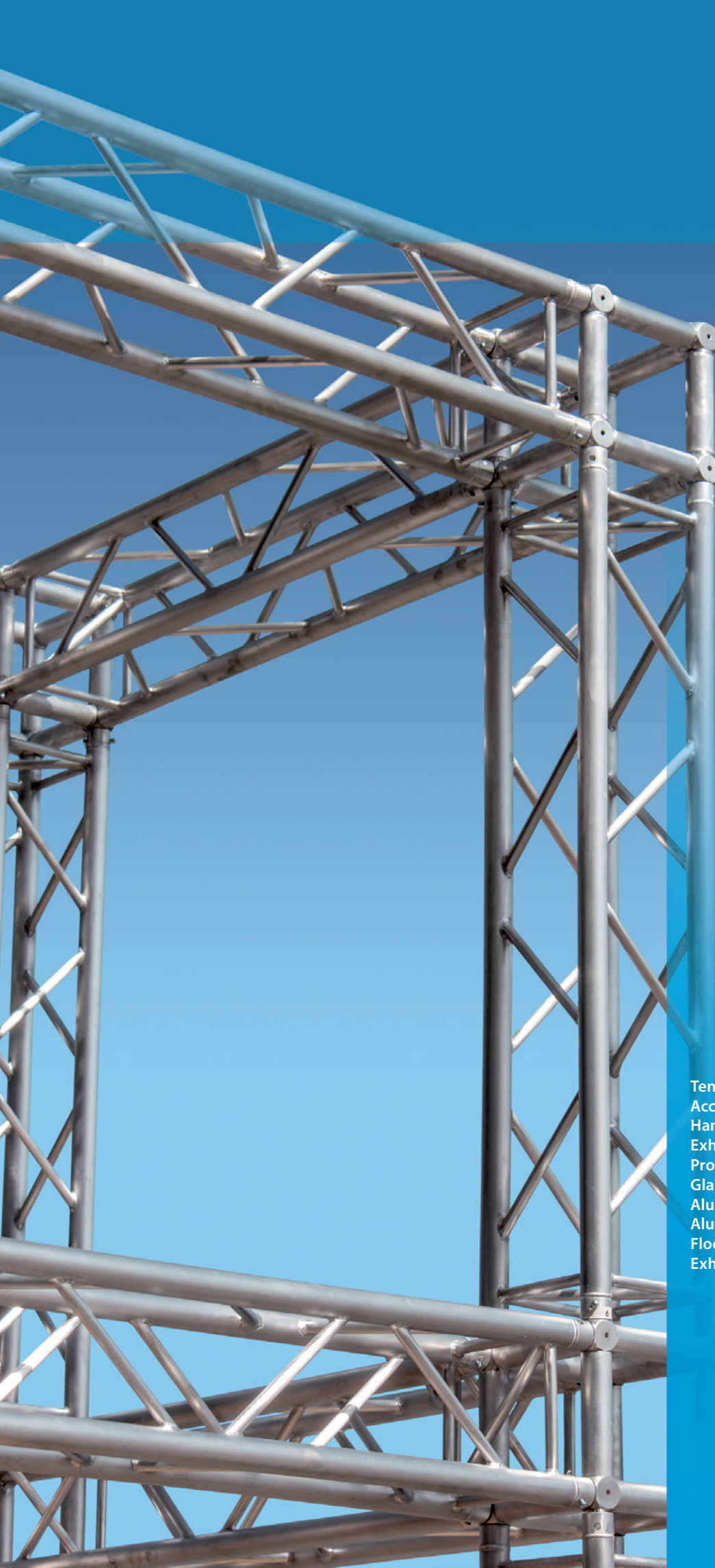

EXHIBITION SOLUTIONS

Tension Fabric Display	128
Accessories	143
Hanging Signs	144
Exhibition Items	146
Profile Stand	154
Glass Wall	155
Aluminium Truss "Duo"	156
Aluminium Truss "Show"	158
Floor System	160
Exhibition Furniture	162

Tension Fabric Display

Spannstoff-Aufsteller sind eine günstige Möglichkeit der Display-Systeme. Man verwendet sie indem man den vollständigen Bezug, wie ein Kissen über den Aluminium-Rahmen stülpt. Mit einem Reißverschluss wird der Bezug geschlossen und gespannt. Durch diese bunte Darstellung der Grafik erhalten Sie auf jedem Display einen atemberaubenden Hintergrund. In mehreren Größen erhältlich. Optional Strahler.

Tension Fabric Display Stands are some of the most affordable/economic display systems. They employ a printed graphic that fits over a tubular aluminum frame like a pillow case. There is an industrial strength zipper which closes and provides tension to the graphic system. The full color graphic allows you to place any image on the display to create a stunning graphic backdrop and create a great visual impact. Available in various sizes. Optional Spotlights.

Les Tension Fabric Display sont un des systèmes display le plus accessibles/économiques. Ils s'utilisent avec une impression ajustable qui couvre la totalité de la structure tubulaire en aluminium et qui se ferme par une fermeture à glissière. Disponibles en plusieurs dimensions. Foyers d'éclairage en option.

Os Tension Fabric Display são dos mais económicos sistemas de displays disponíveis. Utiliza-se uma impressão que cobre na sua totalidade a estrutura tubular de alumínio que se fecha com um zipper. Vários tamanhos disponíveis. Focos opcionais.

Los Tension Fabric son unos de los sistemas de display más asequibles/económicos. Emplean una gráfica impresa que se ajusta sobre un marco tubular de aluminio, creando un gran impacto visual. Cuenta con una cremallera la cual cierra la gráfica y aporta tensión al sistema. Disponible en varios tamaños. Focos opcionales.

Tension Fabric Display 3x3 Curved Kano

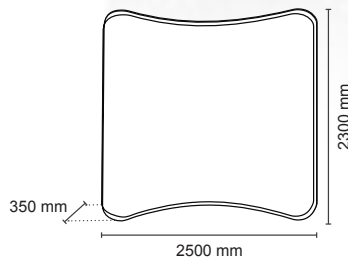

*Print auf Stoff.
Printing on fabric.
Impression sur toile.
Impressão em tecido.
Impresión en tela.

* Optional Strahler.
Optional Spotlights.
Foyers d'éclairage en option.
Focos opcionais.
Focos opcionales.



	QTY	N.W(kg)	G.W(kg)	C.B.M.	Size(mm)
Packing	1	10.70	12.20	0.0284	240x160x740
15.220		2500x2300mm			



Tension Fabric Display 4x3 Curved Zaria

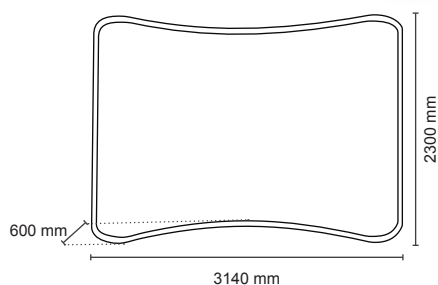

* Optional Strahler.
Optional Spotlights.
Foyers d'éclairage en option.
Focos opcionais.
Focos opcionales.



*Print auf Stoff.
Printing on fabric.
Impression sur toile.
Impressão em tecido.
Impresión en tela.



	QTY	N.W(kg)	G.W(kg)	C.B.M.	Size(mm)
Packing	1	12.7	14.2	0.0343	290x160x740

15.221

3140x2300mm



2 Tension Fabric Display 7x3 Curved Bamako

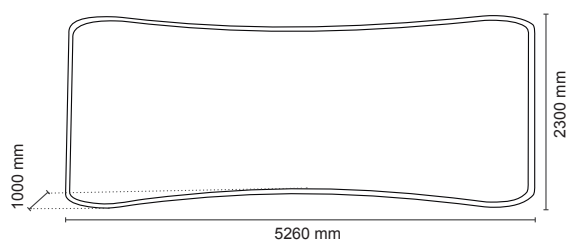

* Optional Strahler.
Optional Spotlights.
Foyers d'éclairage en option.
Focos opcionais.
Focos opcionales.



*Print auf Stoff.
Printing on fabric.
Impression sur toile.
Impressão em tecido.
Impresión en tela.



	QTY	N.W(kg)	G.W(kg)	C.B.M.	Size(mm)
Packing	1	17.10	18.60	0.046	390x160x740
15.222		5260x2300mm			



Tension Fabric Display 2x3 Straight Kayes

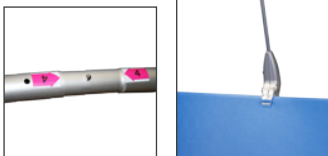
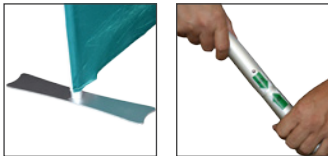

* Optional Strahler.
Optional Spotlights.
Foyers d'éclairage en option.
Focos opcionais.
Focos opcionales.



*Print auf Stoff.
Printing on fabric.
Impression sur toile.
Impressão em tecido.
Impresión en tela.

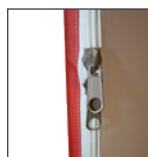
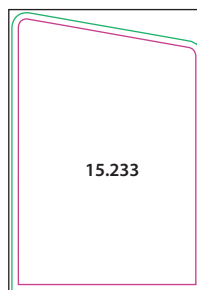
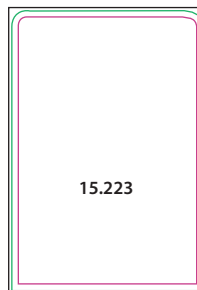

	QTY	N.W(kg)	G.W(kg)	C.B.M.	Size(mm)
Packing	1	15.1	17.6	0.022	190x160x740
15.223		1510x2210mm			



	QTY	N.W(kg)	G.W(kg)	C.B.M.	Size(mm)
Packing	1	15.1	17.6	0.022	190x160x740
15.233		1510x2210mm			



2 Tension Fabric Display 3x3 Straight Bilma

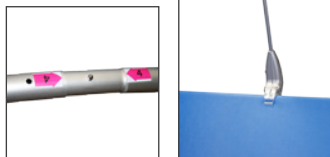
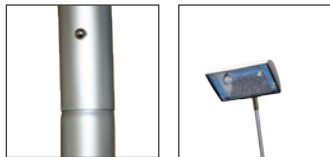

* Optional Strahler.
Optional Spotlights.
Foyers d'éclairage en option.
Focos opcionais.
Focos opcionales.



*Print auf Stoff.
Printing on fabric.
Impression sur toile.
Impressão em tecido.
Impresión en tela.



	QTY	N.W(kg)	G.W(kg)	C.B.M.	Size(mm)
Packing	1	17.1	18.6	0.028	240x160x740
15.224		2470x2210mm			



Tension Fabric Display 4x3 Straight Niamey

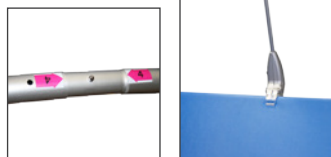
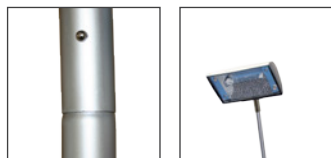
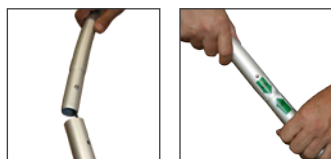

* Optional Strahler.
Optional Spotlights.
Foyers d'éclairage en option.
Focos opcionais.
Focos opcionales.



*Print auf Stoff.
Printing on fabric.
Impression sur toile.
Impressão em tecido.
Impresión en tela.



	QTY	N.W(kg)	G.W(kg)	C.B.M.	Size(mm)
Packing	1	12.7	14.2	0.034	290x160x740
15.225		2950x2210mm			



2 Tension Fabric Display 7x3 Straight Dakar



* Optional Strahler.
 Optional Spotlights.
 Foyers d'éclairage en option.
 Focos opcionais.
 Focos opcionales.



*Print auf Stoff.
 Printing on fabric.
 Impression sur toile.
 Impressão em tecido.
 Impresión en tela.



	QTY	N.W(kg)	G.W(kg)	C.B.M.	Size(mm)
Packing	1	17.1	18.6	0.046	390x160x740

15.226 5830x2210mm



Tension Fabric Display Namibia

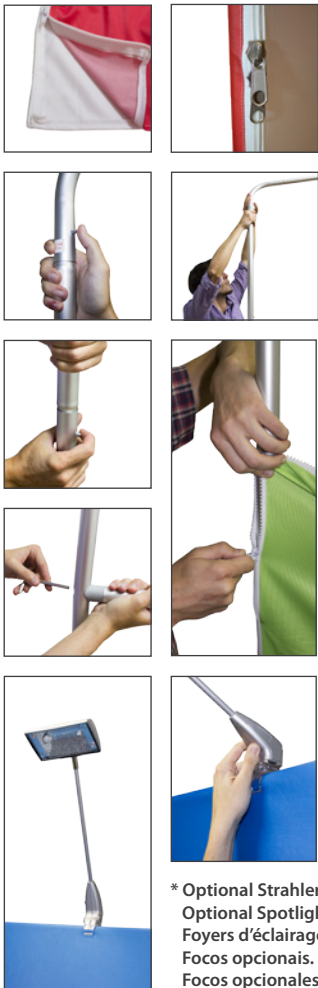

* Optional Strahler.
Optional Spotlights.
Foyers d'éclairage en option.
Focos opcionais.
Focos opcionales.

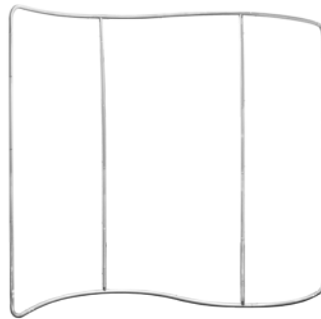

*Print auf Stoff.
Printing on fabric.
Impression sur toile.
Impressão em tecido.
Impresión en tela.

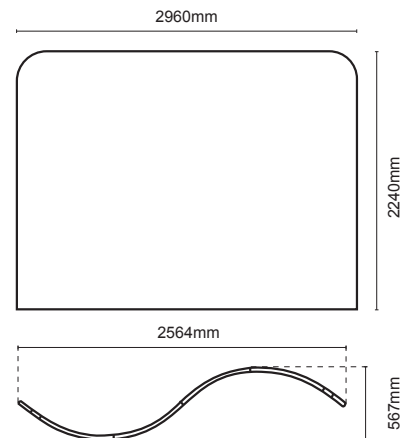

	QTY	N.W(kg)	G.W(kg)	C.B.M.	Size(mm)
Packing	1	9.4	10.3	0.0463	310x180x830
15.218			2564x2240mm		





Tension Fabric Display Kenia



* Optional Strahler.
Optional Spotlights.
Foyers d'éclairage en option.
Focos opcionais.
Focos opcionales.



*Print auf Stoff.
Printing on fabric.
Impression sur toile.
Impressão em tecido.
Impresión en tela.

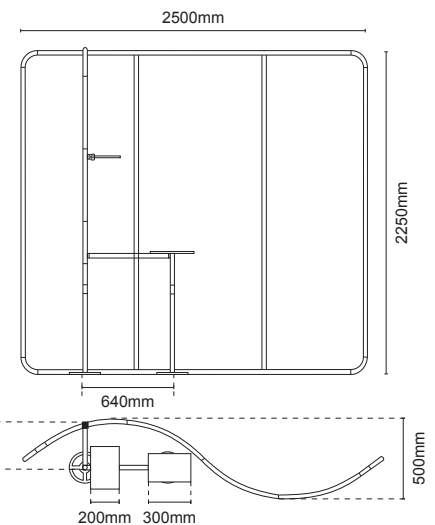

	QTY	N.W(kg)	G.W(kg)	C.B.M.	Size(mm)
Packing	1	16.55	17.65	0.0772	470x155x1060
15.213		2500x2250mm			



Tension Fabric Display Mali



* Tablet nicht enthalten.
Tablet not included.
Tablet non inclus.
Tablet não incluído.
Tablet no incluido.



*Print auf Stoff.
Printing on fabric.
Impression sur toile.
Impressão em tecido.
Impresión en tela.

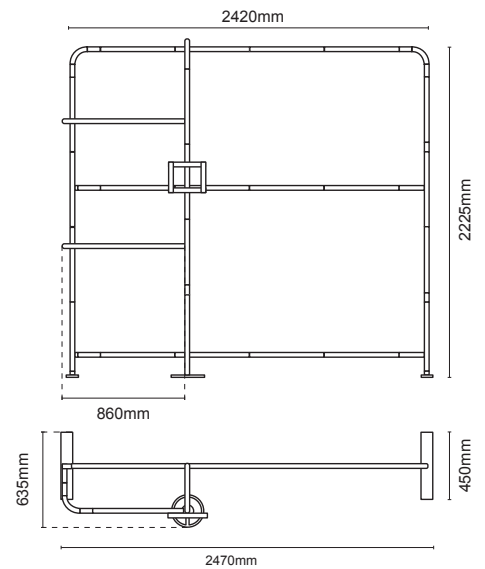

* Optional Strahler.
Optional Spotlights.
Foyers d'éclairage en option.
Focos opcionais.
Focos opcionales.



	QTY	N.W(kg)	G.W(kg)	C.B.M.	Size(mm)
Packing	1	13.85	14.95	0.0772	470x155x1060
15.214			2470x2225mm		

Tension Fabric Display Bangui



* Optional Strahler.
Optional Spotlights.
Foyers d'éclairage en option.
Focos opcionais.

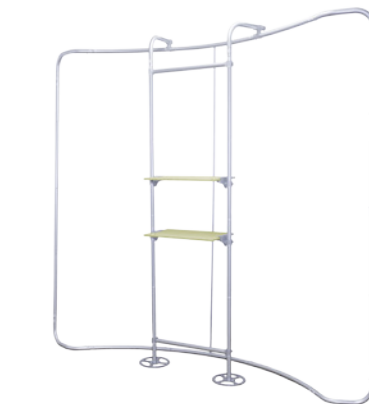

*Print auf Stoff.
Printing on fabric.
Impression sur toile.
Impressão em tecido.
Impresión en tela.

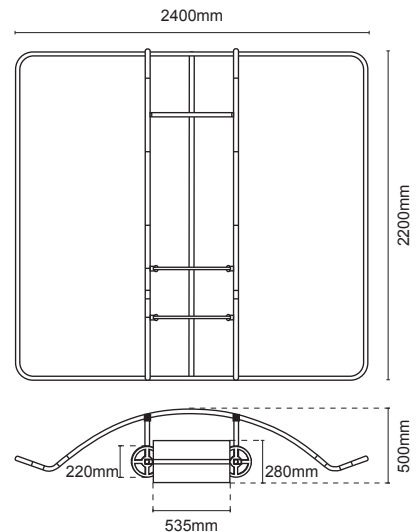

	QTY	N.W(kg)	G.W(kg)	C.B.M.	Size(mm)
Packing	1	15.95	16.9	0.0772	470x155x1060
15.215		2400x2200mm			



Tension Fabric Display Burkina



Safety Holder for Tablet 244x184mm

* Tablet nicht enthalten.
Tablet not included.
Tablet non inclus.
Tablet não incluído.
Tablet no incluido.



*Print auf Stoff.
Printing on fabric.
Impression sur toile.
Impressão em tecido.
Impresión en tela.



* Optional Strahler.
Optional Spotlights.
Foyers d'éclairage en option.
Focos opcionais.
Focos opcionales.

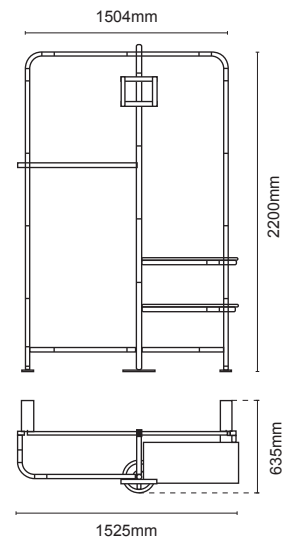

	QTY	N.W(kg)	G.W(kg)	C.B.M.	Size(mm)
Packing	1	15.90	16.10	0.0772	470x155x1060
15.216		1525x2200mm			



2

Tension Fabric Display Zambia



*Print auf Stoff.
Printing on fabric.
Impression sur toile.
Impressão em tecido.
Impresión en tela.

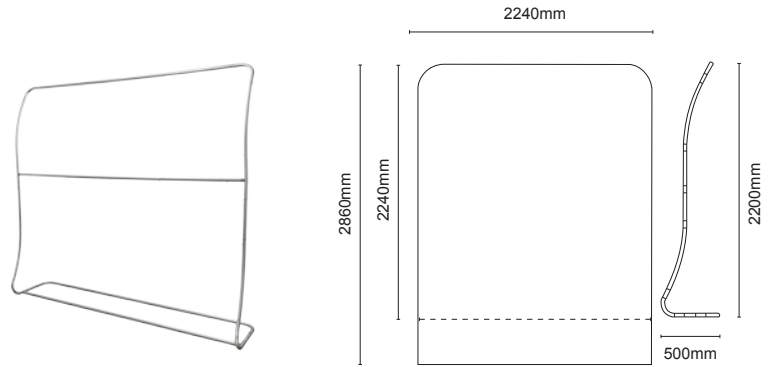

	QTY	N.W(kg)	G.W(kg)	C.B.M.	Size(mm)
Packing	1	9.25	10.0	0.0463	310x180x830
15.219		2240x2200mm			



Tension Fabric Display Mapuko



*Print auf Stoff.
Printing on fabric.
Impression sur toile.
Impressão em tecido.
Impresión en tela.

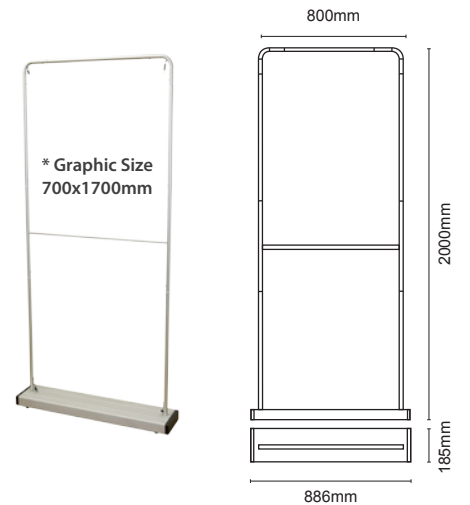

	QTY	N.W(kg)	G.W(kg)	C.B.M.	Size(mm)
Packing	1	3.95	4.45	0.0285	240x125x950
15.217		800x2000mm			



Display Teguisse

Aluminium-Ständer mit angewinkelter Spitze.

Aluminium Tension fabric display stand angled top.

Structure en aluminium pour toile tendue. Angle incurvé.

Estrutura de alumínio com topo angular para colocação de tela mediante tensão.

Tension Fabric Stand con ángulo superior. Fabricado en aluminio.

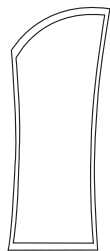

Graphic size: 830x2000mm
Artwork size: 890x2060mm



10.198



*Print auf Stoff.
Printing on fabric.
Impression sur toile.
Impressão em tecido.
Impresión en tela.

	QTY	N.W(kg)	G.W(kg)	C.B.M.	Size(mm)
Packing	1	4.9	5.32	0.04	430x120x610

10.198 830x2060mm

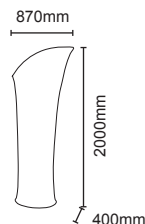

	QTY	N.W(kg)	G.W(kg)	C.B.M.	Size(mm)
Packing	2	4.9 2.2	5.32 2.57	0.04 0.02	430x120x610 280x60x730

10.199 830x2060mm

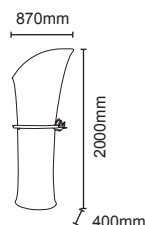

10.199

* Mit Regal / With Shelves / Avec étagères / Com prateleiras / Con estantes.

Display Arona

Aluminium-Ständer mit gebogener Spitze.

Aluminium Tension Fabric Display with curved top.

Structure en aluminium pour toile tendue. Partie supérieure arrondie.

Estrutura de alumínio com topo curvo para colocação de tela mediante tensão.

Tension Fabric Stand con parte superior curvada. Fabricado en aluminio.

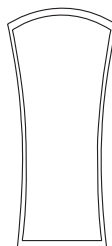

Graphic size: 830x2000mm
Artwork size: 890x2060mm



10.205



*Print auf Stoff.
Printing on fabric.
Impression sur toile.
Impressão em tecido.
Impresión en tela.

	QTY	N.W(kg)	G.W(kg)	C.B.M.	Size(mm)
Packing	1	4.9	5.32	0.04	430x120x610

10.205 830x2000mm

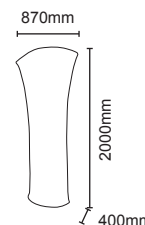

	QTY	N.W(kg)	G.W(kg)	C.B.M.	Size(mm)
Packing	2	4.9 2.2	5.32 2.57	0.04 0.02	430x120x610 280x60x730

10.206 830x2000mm

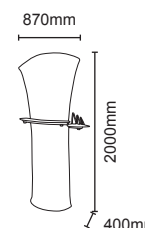

10.206

* Mit Regal / With Shelves / Avec étagères / Com prateleiras / Con estantes.

TENSION FABRIC DISPLAY

2

Counter Manacor

Ovale Aluminium-Spannstoff-Theke.

Oval Aluminium Tension fabric counter with top and wooden base.

Comptoir ovale pour toile tendue. Fabriqué en aluminium et bois.

Balcão de alumínio para colocação de tela mediante tensão, com formato ovalado.

Mostrador ovalado Tension Fabric con estructura de aluminio, base y encimera de madera.



*Print auf Stoff.
Printing on fabric.
Impression sur toile.
Impressão em tecido.
Impresión en tela.

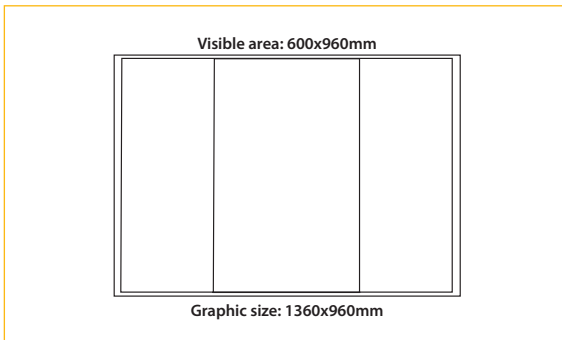

	QTY	N.W(kg)	G.W(kg)	C.B.M.	Size(mm)
Packing	1	7.0	7.44	0.07	440x130x640

10.318

1360x960mm

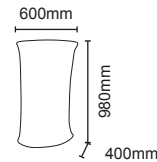

Counter Mahon

Aluminium-Spannstoff-Theke in Wassertropfen-Form.

"Raindrop" Tension Fabric Display made of aluminum and wood.

Comptoir en goutte d'eau pour toile tendue. Fabriqué en aluminium et bois.

Balcão de alumínio para colocação de tela mediante tensão, com formato gota de água.

Mostrador Tension Fabric "Gota de agua" fabricado en aluminio y madera.



*Print auf Stoff.
Printing on fabric.
Impression sur toile.
Impressão em tecido.
Impresión en tela.

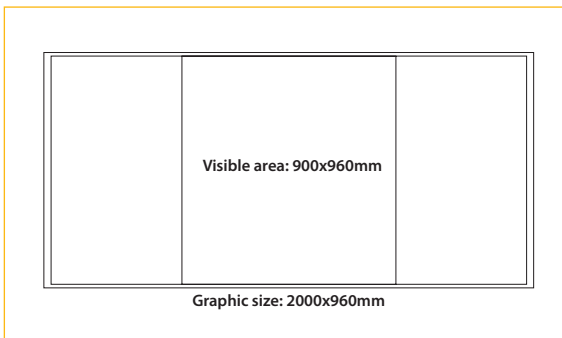

	QTY	N.W(kg)	G.W(kg)	C.B.M.	Size(mm)
Packing	1	10.5	10.93	0.13	500x140x960

10.319

2000x960mm

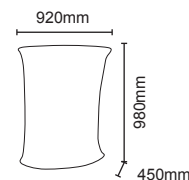

Spotlight Tension Fabric Display

Strahler mit Kabel, Einbaustecker und Birne.
Ideal für Tension Fabric Display.

Spotlight with cable, fitted plugs and bulb.
Ideal for Tension Fabric Display.

Foyer d'éclairage pour supports promotionnels Tension Fabric Display. Se branche directement au secteur.

Foco de iluminação para estruturas Tension Fabric Display, apropriado para ligar diretamente à corrente.

Foco de iluminación para soporte promocional Tension Fabric Display. Funciona directamente a corriente.



	QTY	N.W(kg)	G.W(kg)	C.B.M.	Size(mm)
Packing	1	1.0	1.15	0.006	173x60x590mm
13.450		150 W			
13.451		150 W			

Fastener pieces for Tension Fabric Display

Befestigung für Spannstoff-Aufsteller.

Fastener pieces for joining several Tension Fabric Displays.

Pièces pour assembler plusieurs Tension Fabric Display.

Peças para união de estruturas Tension Fabric Display.

Piezas para unir varios Tension Fabric Display.

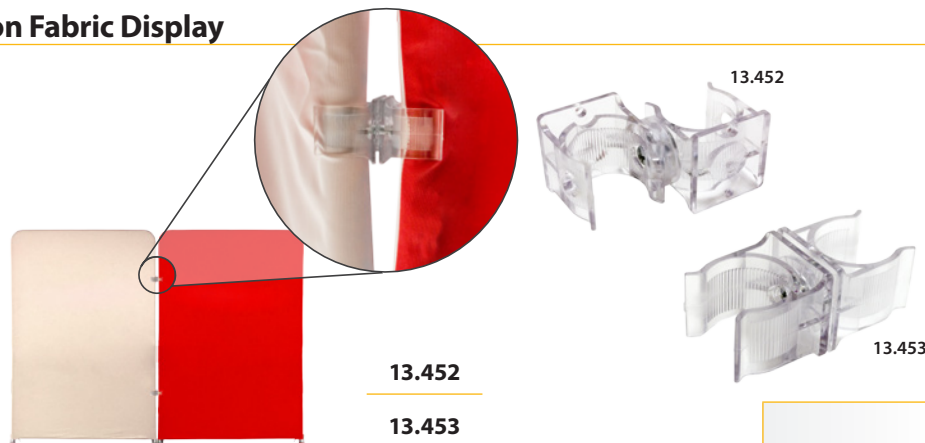

Silicon Strip

Silikon-Band zum Spannen der Spannstoff-Aufsteller.

Silicone for the manufacture of fabric for the Tension Fabric Display stands.

Ruban en silicone pour l'installation de toile tendue sur Tension Fabric Display.

Silicone para a confecção de tela para as estruturas Tension Fabric Display.

Silicona para la confección de tela en los soportes Tension Fabric Display.

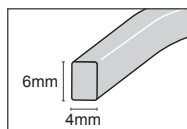

13.465	Pack 10m/l	
--------	------------	--

Hanging Signs

DE Deckenaufhänger ermöglichen das Werben in der Höhe. Mit diesen montagefreundlichen Aluminium-Profilen und dem Stretch-Stoff in hoher Qualität können Sie in der Höhe ganz einfach werben. Weil das System so einfach und leicht ist kann es überall eingesetzt werden. Lieferung mit Halterung und Tasche.

UK The Hanging Signs provide a great visual impact at long distance. With easy-assembly aluminium profiles and high-quality printed graphics where you can expose your message at height. Lightweight and easy to hang from the ceiling by wires. This system comes ready to be used anywhere. Supplied with mounting parts and carry bag.

FR Les Hanging Signs ont un grand impact visuel. Profils en aluminium, très faciles à monter, et impression de qualité sur toile tendue permettent l'exposition rapide de messages en hauteur. Léger et facile à suspendre, ce système est idéal pour tous les espaces.

PT Os Hanging Signs transmitem um grande impacto visual. Com perfis de alumínio e de montagem fácil, pode colocar uma mensagem em altura. Leve e fácil de pendurar, este sistema é adequado a qualquer espaço. Fornecido com peças de montagem e saco de transporte.

ES Los Hanging Signs aportan un gran impacto visual a larga distancia. Con perfiles de aluminio fáciles de montar y una gráfica impresa de alta calidad donde puedes situar un mensaje en altura. Ligeros y fáciles de colgar mediante cables del techo. Este sistema viene preparado para emplearlo en cualquier lugar. Se suministra con piezas de montaje y bolsa de transporte.



Hanging Sign Square



*Print auf Stoff.
Printing on fabric.
Impression sur toile.
Impressão em tecido.
Impresión en tela.

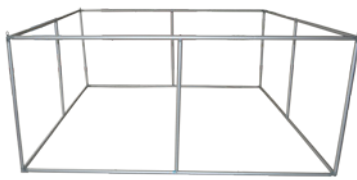

Ref: 15.227 - 2438mm
Ref: 15.228 - 4877mm

Ref: 15.227 - 1067mm
Ref: 15.228 - 1219mm

	QTY	N.W(kg)	G.W(kg)	C.B.M.	Size(mm)
Uni.	1	10.5	13.6	0.1237	370x220x1520

15.227



2438x1067mm



	QTY	N.W(kg)	G.W(kg)	C.B.M.	Size(mm)
Uni.	1	16.3	19.7	0.1400	370x220x1720

15.228



4877x1219mm



Hanging Sign Circle

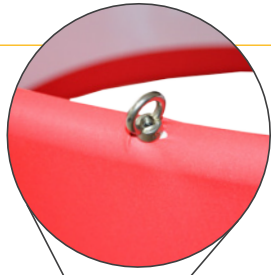

*Print auf Stoff.
Printing on fabric.
Impression sur toile.
Impressão em tecido.
Impresión en tela.



	QTY	N.W(kg)	G.W(kg)	C.B.M.	Size(mm)
Uni.	1	5.0	7.0	0.0663	320x170x1220

15.229 Ⓢ Ø 1524x762mm

	QTY	N.W(kg)	G.W(kg)	C.B.M.	Size(mm)
Uni.	1	9.3	12.3	0.0993	370x220x1220

15.230 Ⓜ Ø 3048x610mm

Hanging Sign Tapered Circular



*Print auf Stoff.
Printing on fabric.
Impression sur toile.
Impressão em tecido.
Impresión en tela.



	QTY	N.W(kg)	G.W(kg)	C.B.M.	Size(mm)
Uni.	1	9.8	12.9	0.140	370x220x1720

15.231 Ⓢ Ø 3048/2438x1067mm

	QTY	N.W(kg)	G.W(kg)	C.B.M.	Size(mm)
Uni.	1	12.4	15.8	0.1400	370x220x1720

15.232 Ⓜ Ø 4627/3658x1219mm

Panel Banner Vidago

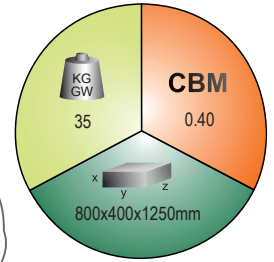

Germany Magnetisches Panel-System. Mit geraden Rahmen, um die Grafikpanel mittels Magnete-Streifen zu befestigen.

- 2 Stahl-Rundsockel.
- 2 Alu-Stangen.
- 4 Aluminiumgehäuse (700x1000mm).
- 2 Leuchten.
- 8 PS-Panel.
- Connectors.

UK Magnetic Panel System. Using straight frames to which the graphic panel can be attached by means of magnetic strips.

- 2 round steel base.
- 2 aluminum poles.
- 4 aluminum cases (700x1000mm).
- 2 spotlights.
- 8 pieces of PS of panel.
- Connectors.

France Système de panneaux magnétiques. Affichage fixé sur cadre avec ruban magnétique.

- 2 bases rondes en acier.
- 2 poteaux en aluminium.
- 4 cadres en aluminium (700x1000mm).
- 2 foyers d'éclairage.
- 8 pièces de panneau PS.
- Connecteurs.

Brazil Sistema de Painéis Magnéticos. Utilização de marcos rectos às quais os painéis gráficos se unem através de barras magnéticas.

- 2 bases redondas de aço.
- 2 postes de alumínio.
- 4 marcos de alumínio (700x1000mm).
- 2 focos.
- 8 peças de painel PS.
- Conectores.

Spain Sistema de panel magnético. Haciendo uso de marcos rectos a los cuales el panel gráfico puede unirse por bandas magnéticas.

- 2 bases redondas de acero.
- 2 postes de aluminio.
- 4 marcos de aluminio (700x1000mm).
- 2 focos.
- 8 pcs PS panel.
- Conectores.



10.430

2100x2000mm



Catania



 Tragbarer Wand-Aufsteller. Die Konstruktion ermöglicht ein schnelles und einfaches Aufbauen. Druck und Grafik sind nicht inklusive.

- Aluminium-Profil, Standfüße und zwei Spotlights.
- Oxford Stoffbeutel: 1 Stück.

 Portable Display Wall. The construction makes an easy and fast assembly. Printing and graphics are not included.

- Aluminium Profile, base feet and two spotlights.
- Oxford Cloth bag: 1 unit.

 Display portable, facile et rapide à monter. Visuel non inclus.

- Profils en aluminium, bases et foyers d'éclairage.
- Valise de transport Oxford Cloth: 1 unité.

 Display portátil. De fácil e rápida montagem. Material de impressão e gráfica não incluída.

- Perfis de alumínio, bases e focos.
- Mala de transporte Oxford Cloth: 1 unidade.

 Display portátil de fácil y rápido montaje. Impresión y gráfica no incluidas.

- Perfil de aluminio, bases y dos focos.
- Maleta de transporte: 1 unidad.

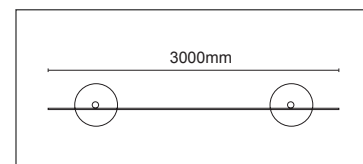
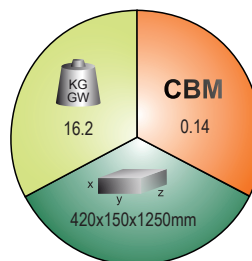
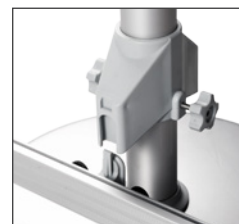

10.647

3000x2000mm



Perugia



 Tragbarer Wand-Aufsteller. Die Konstruktion ermöglicht ein schnelles und einfaches Aufbauen. Druck und Grafik sind nicht inklusive.

- Aluminium-Profil, Standfüße und zwei Spotlights.
- Oxford Stoffbeutel: 1 Stück.

 Portable Display Wall. The construction makes an easy and fast assembly. Printing and graphics are not included.

- Aluminium Profile, base feet and two spotlights.
- Oxford Cloth bag: 1 unit.

 Display portable, facile et rapide à monter. Visuel non inclus.

- Profils en aluminium, bases et foyers d'éclairage.
- Valise de transport Oxford Cloth: 1 unité.

 Display portátil. De fácil e rápida montagem. Material de impressão e gráfica não incluída.

- Perfis de alumínio, bases e focos.
- Mala de transporte Oxford Cloth: 1 unidade.

 Display portátil de fácil y rápido montaje. Impresión y gráfica no incluidas.

- Perfil de aluminio, bases y dos focos.
- Maleta de transporte: 1 unidad.

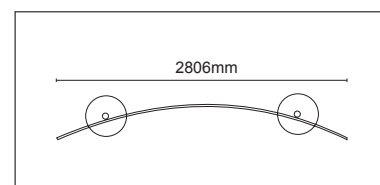
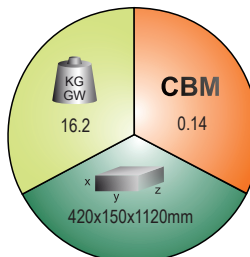

10.648

3000x2000mm



Limoges

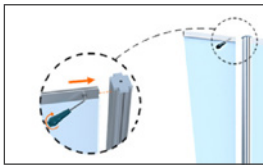
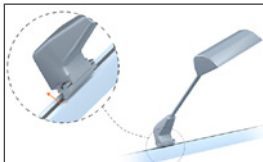
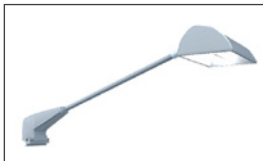

Smartes und stabiles Ausstellungssystem. Einfach zu installieren. Druck nicht inklusive.

- Aluminium-Rahmen 2000x2200mm.
- Dach-Regal: 1.
- Flügel (2 Stück) (L&R).
- Tisch: "V"-Form: 1.
- Spotlights (2 Stück).
- Plastiktasche.

Stable and elegant Exhibition System. Easy to be assembled. Printing is not included.

- Aluminium frame 2000x2200mm.
- Header Board. Shelves: 1.
- Wings (2 units) (L&R).
- Table en "V": 1.
- Spotlights (2 units).
- Plastic Packing Case.

Système d'exposition stable. Montage facile. Visuel non inclus.

- Cadre en aluminium 2000x2200mm.
- Plaque supérieur. Étagère: 1.
- Ailes (2 unités) (L&R).
- "V" Shape Table: 1.
- Foyers d'éclairage (2 unités)
- Valise de transport en plastique

Sistema de exibição estável. De fácil montagem. Impressão não incluída.

- Marco de alumínio 2000x2200mm.
- Placa superior. Prateleira: 1.
- Alas (2 unidades) (L&R).
- Mesa em forma de "V": 1.
- Focos (2 unidades).
- Mala de transporte em plástico.

Sistema de exhibición elegante y estable de fácil montaje. Impresión no incluida.

- Marco de aluminio 2000x2200mm.
- Placa superior. Estantes: 1.
- 2 Alas (izquierda, derecha).
- Mesa en forma de "V": 1.
- 2 focos.
- Maleta de transporte de plástico.

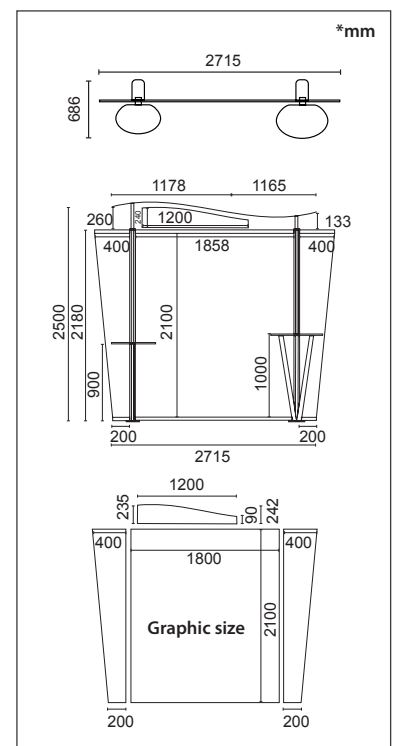
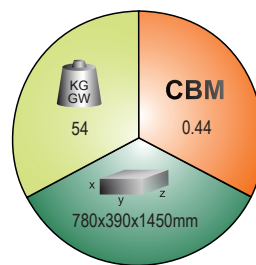

10.153



Opole

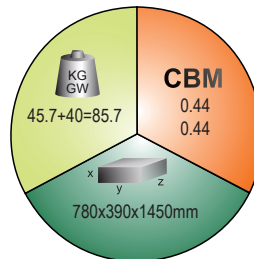
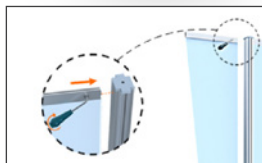
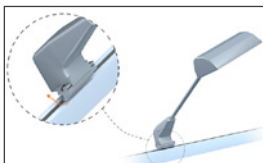
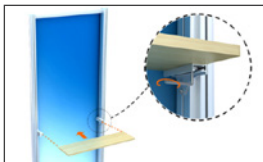
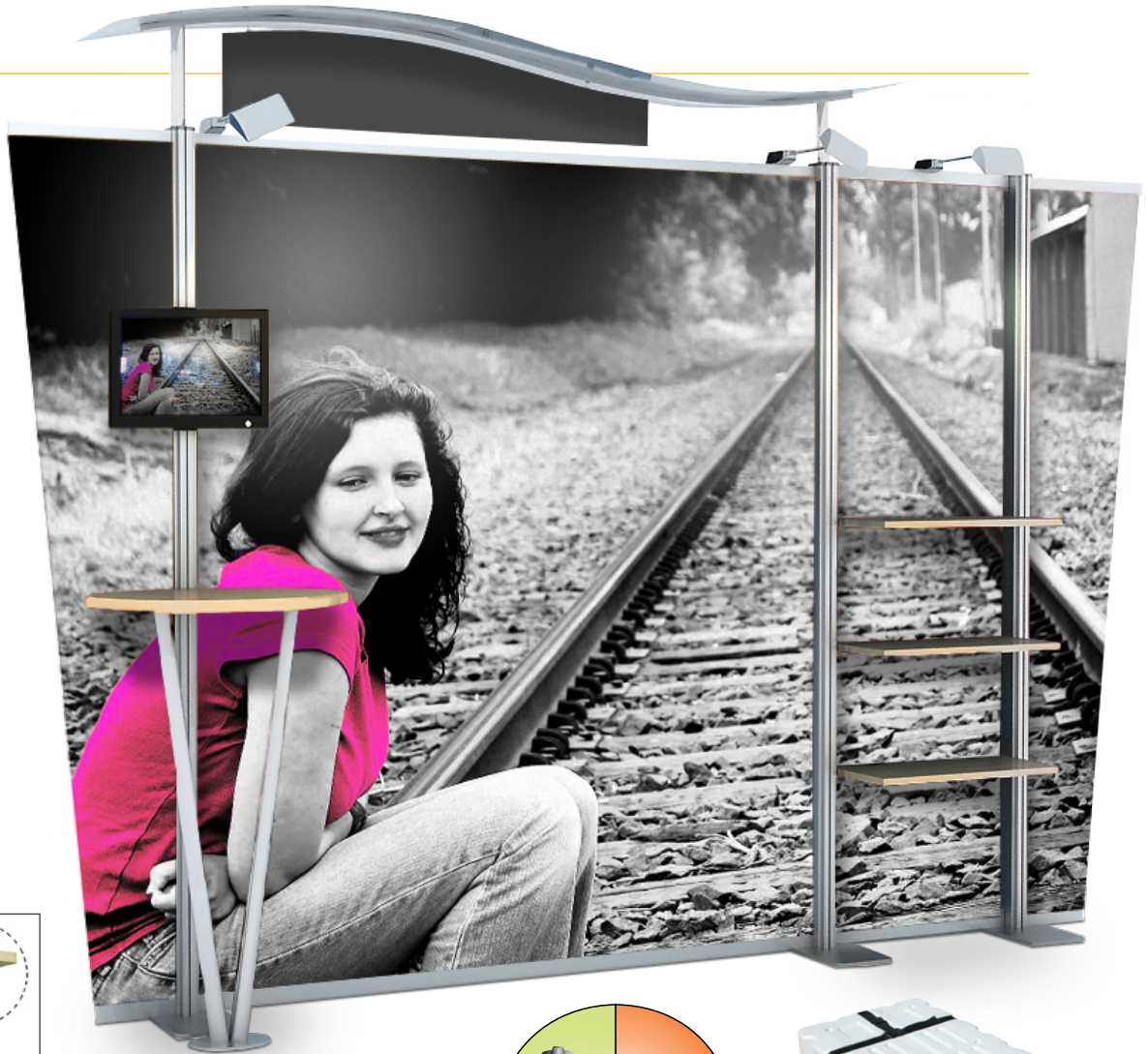

Smartes und stabiles Ausstellungssystem. Einfach zu installieren. Druck nicht inklusive.

- Aluminium-Rahmen 2850x2200mm.
- Kopfteil: 3.
- Seitenteile (2 Stück) (L&R).
- Tisch: "V"-Form: 1.
- Spotlights (3 Stück). LCD Fixierer.
- Kunststoffkoffer: 1.

Stable and elegant Exhibition System. Easy to be assembled. Printing is not included.

- Aluminium frame 2850x2200mm.
- Header Board. Shelves: 3.
- Wings (2 units) (L&R).
- "V" Shape Table: 1.
- Spotlights (3 units). LCD fixer.
- Plastic Packing Case: 1.

Système d'exposition stable. Montage facile. Visuel non inclus.

- Cadre en aluminium 2850x2200mm.
- Plaque supérieur. Étagères: 3.
- Ailes (2 unités) (L&R).
- Table en "V": 1.
- Foyers d'éclairage (3 unités).
- Valise de transport en plastique: 1 unité.

Sistema de exibição estável. De fácil montagem. Impressão não incluída.

- Marco de alumínio 2850x2200mm.
- Placa superior. Prateleiras: 3.
- Alas (2 unidades) (L&R).
- Mesa em forma de "V": 1.
- Focos (3 unidades). Fixador de LCD.
- Mala de transporte em plástico: 1.

Sistema de exhibición elegante y estable de fácil montaje. Impresión no incluida.

- Marco de aluminio 2850x2200mm.
- Placa superior. Estantes: 3.
- 2 Alas (izquierda, derecha).
- Mesa en forma de "V": 1.
- 3 focos. Fijador de LCD.
- Maleta de transporte de plástico.

10.192

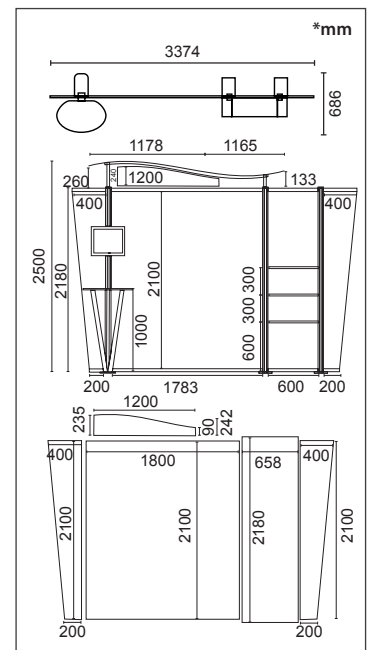

Kassel

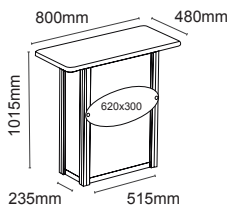

Smartes und stabiles Ausstellungssystem. Einfach zu installieren. Druck nicht inklusive.

- Aluminium-Rahmen 2824x2400mm.
- Dach.
- Tisch.
- Regale: 3.
- Spotlights (3 Stück).
- Plastiktasche.

Smart and elegant Exhibition System. Easy to be assembled. Printing is not included.

- Aluminium frame 2824x2400mm.
- Header Board.
- Counter.
- Shelves: 3.
- Spotlights (3 units).
- Plastic Packing Case.

Système d'exposition stable. Montage facile. Visuel non inclus.

- Cadre en aluminium 2824x2400mm.
- Plaque supérieur.
- Comptoir.
- Étagères: 3.
- Foyers d'éclairage (3 unités).
- Valise de transport en plastique.

Sistema de exibição estável. De fácil montagem. Impressão não incluída.

- Marco de alumínio 2824x2400mm.
- Placa superior.
- Balcão.
- Shelves: 3.
- Focos (3 unidades).
- Mala de transporte em plástico.

Sistema de exhibición elegante y estable de fácil montaje. Impresión no incluida.

- Marco de aluminio 2824x2400mm.
- Placa superior.
- Mostrador.
- Estantes: 3.
- 3 focos.
- Maleta de transporte de plástico.

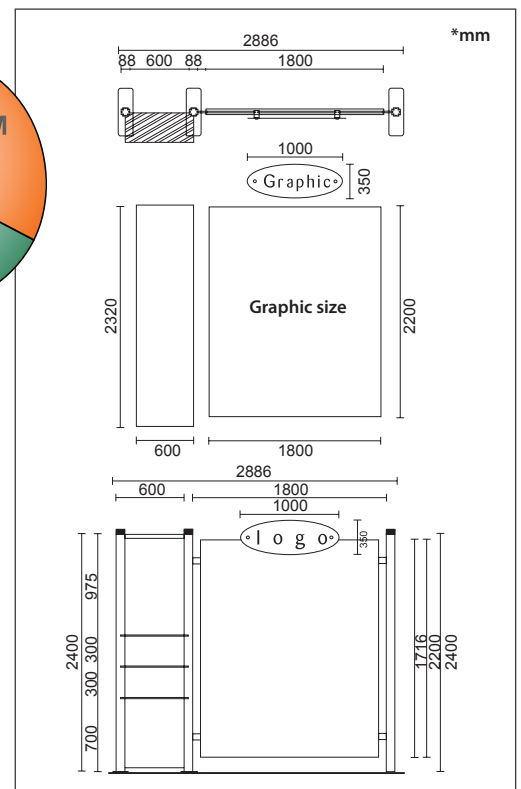
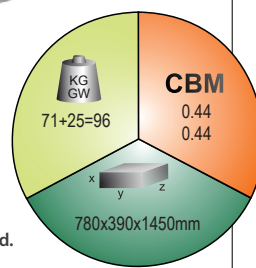

10.364

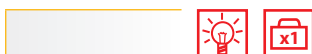

Pescara

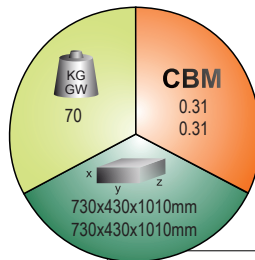

Flexibles Pop-Up-System. Einfach zu installieren. Druck nicht inklusive

- Pop-Up Rahmen 3x1 gerade x 3 sets.
- Eckverbindungen: 3 sets.
- Kunststoffkoffer: 2 Stück.

Flexible Pop-Up wall system. Easy to be assembled. Printing is not included.

- Straight Pop-Up Frame for 3x1: 3 units.
- Corner Accessories: 3 units.
- Plastic trolley Case: 2 units.

Pop-Up magnétique facile à monter. Visuel non inclus.

- Pop-Up 3x1: 3 unités.
- Accessoires pour les angles: 3 unités.
- Valise de transport en plastique: 2 unités.

Pop-Up magnético de fácil montagem. Impressão não incluída.

- Pop-Up 3x1 recto: 3 unidades.
- Acessórios das esquinas: 3 unidades.
- Mala de transporte em plástico: 2 unidades.

Sistema de Pop-Up flexible y de fácil montaje. Impresión no incluida.

- Estructura recta de Pop-Up 3x1: 3 unidades.
- Accesorios para esquinas: 3 unidades.
- 2 Maletas de plástico.

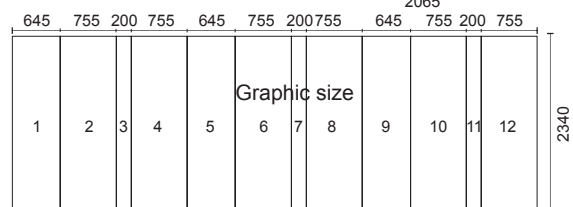
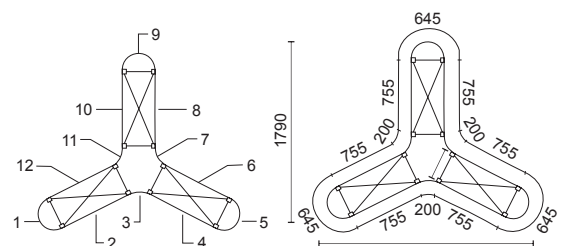

*mm

10.639



Florence

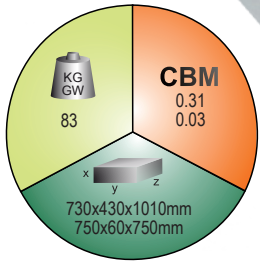

Flexibles Pop-Up-System. Einfach zu installieren. Druck nicht inklusive.

- Pop-Up Rahmen 3x3 gerade x 1/ Pop-Up 3x2 gerade x 2 Stück.
- Eckverbindungen: 3 Stück.
- Spotlights: 2 Stück.
- Kunststoffkoffer: 2 Stück

Flexible Pop-Up wall system. Easy to be assembled. Printing is not included.

- Straight Pop-Up Frame 3x3: 1 unit / Straight Pop-Up frame 3x2: 2 units.
- Accessories corners: 3 units.
- Spotlights: 2 units.
- Plastic trolley Case: 2 units.

Pop-Up magnétique facile à monter. Visuel non inclus.

- Pop-Up 3x3: 1 unité. / Pop-Up 3x2: 2 unités.
- Accessoires pour les angles: 3 unités.
- Foyer d'éclairage: 2 unités.
- Valise de transport en plastique: 2 unités.

Pop-Up magnético de fácil montaje. Impresión no incluida.

- Pop-Up 3x3 recto: 1 unid. / Pop-Up 3x2 recto: 2 unidades.
- Accesorios das esquinas: 3 unidades.
- Focos: 2 unidades.
- Mala de transporte em plástico: 2 unidades.

Sistema de Pop-Up flexible y de fácil montaje. Impresión no incluida.



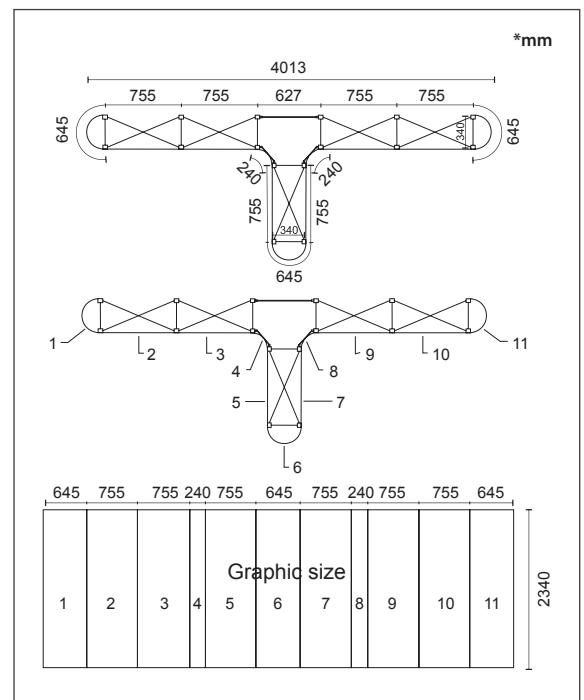

- Estructura recta de Pop Up 3x3 recto: 1 unidad / Pop-Up 3x2 recto: 2 unidad.
- Accesorios para esquinas: 3 unidades.
- Focos: 2 unidades.
- 2 Maletas de plástico.



10.644



Profile Stand

-  Aluminium-Profil für Messe- und Ausstellungsstände.
-  Aluminium profile for exhibition stands.
-  Profils en aluminium pour préparation de stand.
-  Perfiles de aluminio para montagem de stands.
-  Perfilería de aluminio para el montaje de stands.

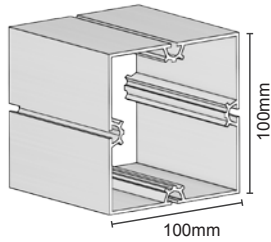
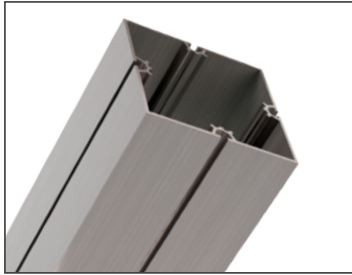



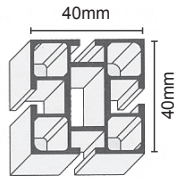

15.116 **100mm**







15.118 **40mm**



Aluminium Connector for Profile 100mm

-  Für 100mm Profile müssen Sie 2 Schlösser und für 40mm Profile 1 Schloss verwenden.
-  To complete the union is needed the use of 1 "lock" profile of 40mm and 2 "locks" in the profile of 100mm.
-  Pour les profilés de 40mm il faut utiliser 1 « look » et pour ceux de 100mm il faut utiliser 2 « look ».
-  Para unir perfiles é necessário 1 "lock" para o perfil de 40mm e de 2 "locks" para o perfil de 100mm.
-  Para completar la unión es necesario el uso de 1 "lock" en el perfil de 40mm y de 2 "locks" en el perfil de 100mm.

Plastic Pieces for Tension Graphics

-  Planen-Spannhaken für Profile.
-  Plastic connector for attaching canvas in profile system.
-  Pièces en plastique pour fixation de toile aux profilés.
-  Conector de plástico para colocação de lona em perfil.
-  Conector de plástico para la sujeción de lonas en perfilera.



15.723 **x10** 

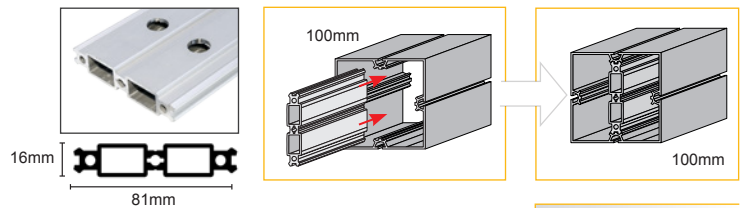

15.117 **Conector 100mm**

Lock

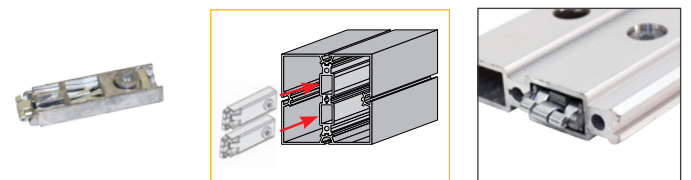

15.119 **Lock 100mm**

Glass Wall

 Punkthalter für Glas- und Acrylwandscheiben. Geeignet für Standprofil 100mm.

 Glass wall systems are premium quality exhibit pieces that offer infinite versatility to help display your products or services. It's used with 100mm aluminium profile stand. Material: Steel.

 Système de fixation modulable pour vitres ou acryliques permettant le montage de stands. S'utilise avec un profil stand de 100mm.

 Sistema de fixação de vidros ou acrílicos para a montagem de stands. Utiliza-se com um perfil de 100mm. Material: Aço.

 Sistema de fijación de cristales o acrílicos para la realización de stand. Se utiliza con el profile stand de 100mm. Material: Acero.

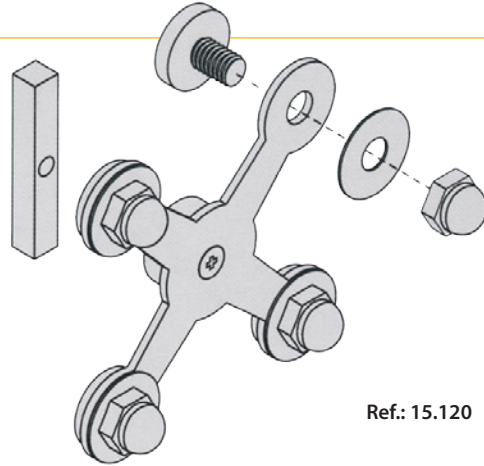



Ref.: 15.120

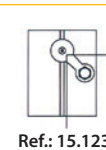
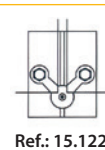
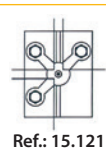
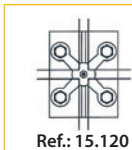
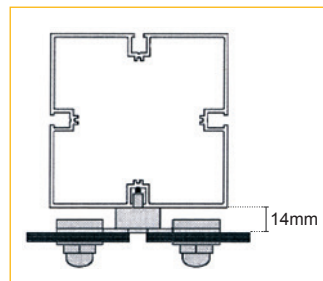
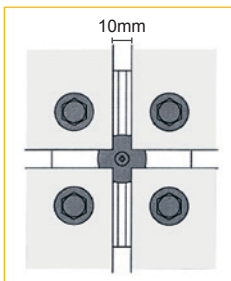
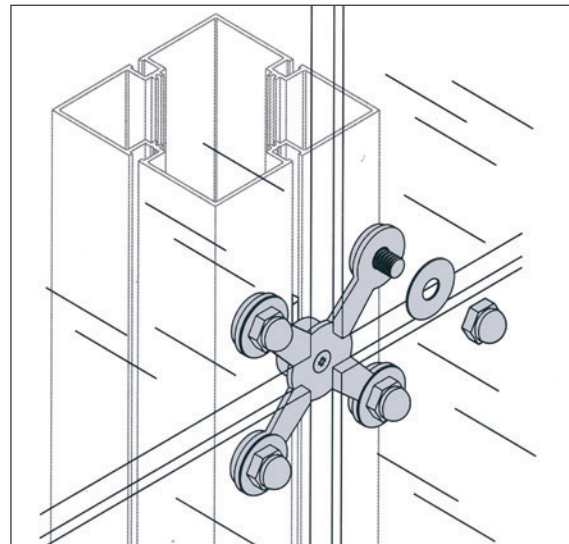
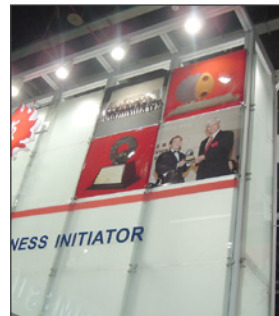

Front View

Top View



15.120	4 Parts	
15.121	3 Parts	
15.122	2 Parts	
15.123	1 Part	

Maßabstände.
 Dimensions for making holes on glass or acrylic sheets.
 Dimensions pour les trous dans le cristal ou l'acrylique.
 Medidas para furos em vidro ou acrílico.
 Medidas para agujeros en cristal o en acrílico.

ALUMINIUM TRUSS "DUO"

2

Aluminium Truss "Duo"

2-Punkt-Winkel zur Erweiterung des Traversensystems oder zur Befestigung von Konstruktions- und Gestaltungszubehör.

Aluminium Truss "Duo" formed by two aluminum bars, color "natural silver." Light weight, high strength and easy assembly.

Colonne de Truss "Duo" formée par deux barres d'aluminium couleur "argent naturel". Poids léger, grande résistance, montage facile.

Coluna Truss "Duo" formada por duas barras de alumínio em cor prateada. Leve, de grande resistência e fácil montagem.

Larguero de Truss "Duo", formado por dos barras de aluminio, color "plata natural". Peso ligero, gran resistencia y fácil montaje.

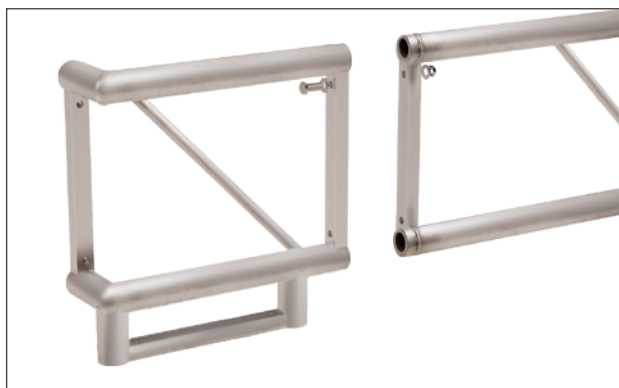
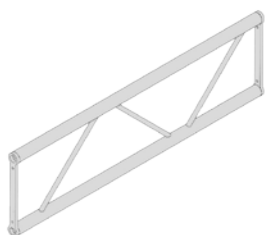

Code	Length (mm)	Diagram	Length (mm)	Diagram	Diagram
15.305	500mm		500mm		
15.060	1000mm		1000mm		
15.063	1500mm		1500mm		
15.066	2000mm		2000mm		
15.306	2500mm		2500mm		
15.307	3000mm		3000mm		

ALUMINIUM TRUSS "DUO"

Aluminium "Duo" Truss Connector

2-Punkt-Winkel zur Erweiterung des Traversensystems oder zur Befestigung von Konstruktions- und Gestaltungsbehör.

Aluminium Truss connector for vertical and horizontal "duo" Truss. Are available different types of connections.

Vis pour le montage du Truss aluminium, fabriquée en acier. Vis fournie avec son écrou.

União para Truss "Duo" fabricada em alumínio. Disponíveis vários tipos de ligações.

Conector para Truss tipo "Duo" fabricado en aluminio. Disponibles varios tipos de conexiones.

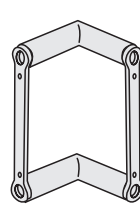

Ref.: 15.068

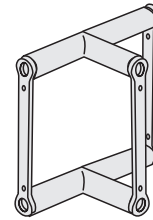

Ref.: 15.069

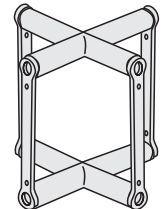

Ref.: 15.073

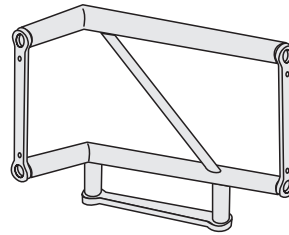

Ref.: 15.070

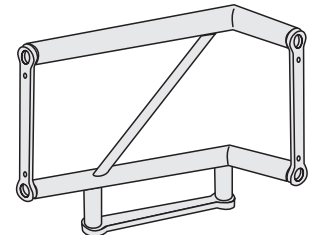

Ref.: 15.071

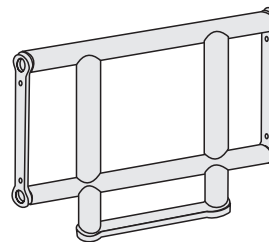

Ref.: 15.072

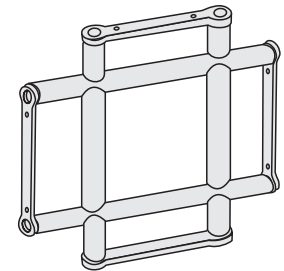

Ref.: 15.074

15.068	2 connection sides	
15.069	3 connection sides	
15.070	3 connection sides	
15.071	3 connection sides	
15.072	3 connection sides	
15.073	4 connection sides	
15.074	4 connection sides	

Screws for Aluminium Truss

Stahl-Schraube mit Mutter für Schraubverbindung von Traversen.

Screws for mounting the aluminum Truss. Made of steel. Screw with a corresponding nut is supplied.

Vis pour le montage du Truss aluminium, fabriqués en acier. Vis fournie avec son écrou.

Parafuso com porca para estrutura Truss em alumínio. Fabricado em aço.

Tornillería para el montaje del Truss de aluminio. Fabricados en acero. Se suministra el tornillo con su correspondiente tuerca.

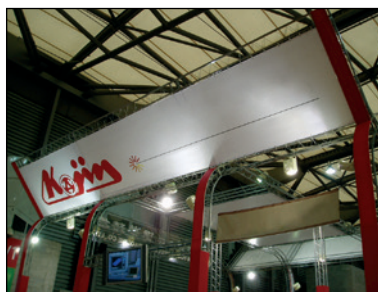
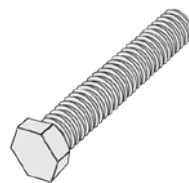
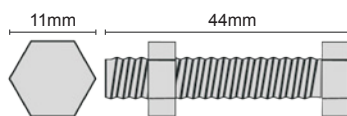

15.040 44x11mm

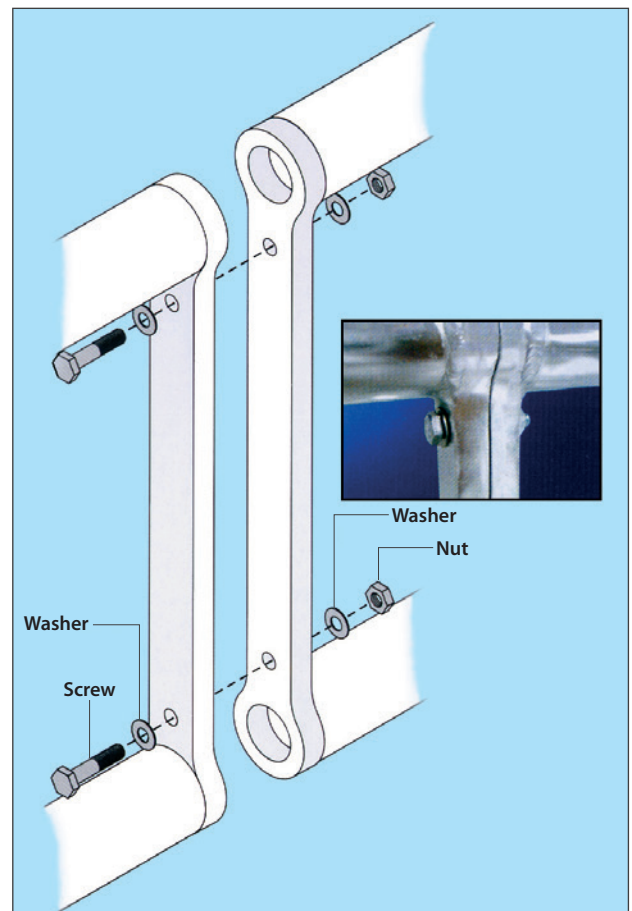



ALUMINIUM TRUSS "SHOW"

2

Aluminium Truss "Show"

 4-Punkt-Traverse von Truss mit Haupt-Rohrdurchmesser 32mm aus Aluminium, silberfarben. Vielfältig einsetzbar im Veranstaltungsbereich, individuelle Gestaltung durch zusätzliches Aufhängen von Werbeträgern, Licht oder ähnlichem Zubehör. Hohe Belastbarkeit, trotz ihres leichten Gewichts, schnelle und einfache Montage.





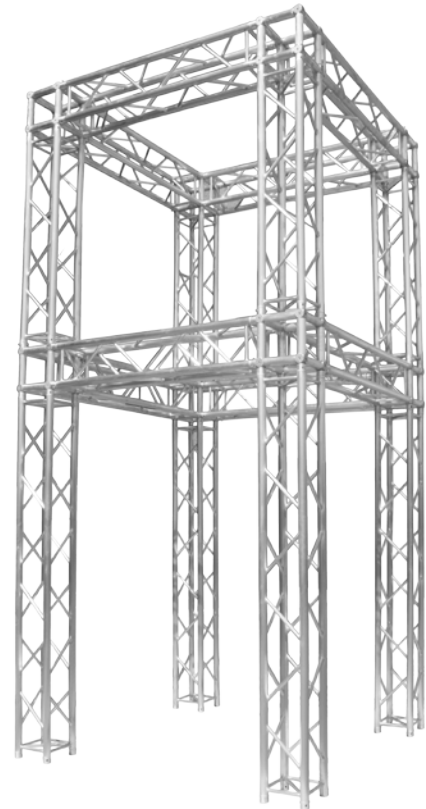
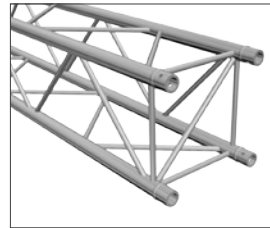
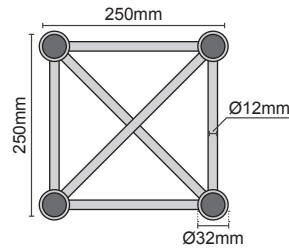

 Vertical aluminium Truss, 32 mm diameter. Ideal for producing and assembling a booth, venues, outdoor events, placing graphics, etc. It is characterized by its great resistance, lightweight and easy assembly. Colour: natural silver.

 Colonne de Truss fabriquée en aluminium, couleur "argent naturel" avec tubes de 32mm de diamètre. Idéal pour la réalisation et le montage de stands, scènes, événements extérieurs, suspension de bâches, etc. Léger, résistant et facile à monter.

 Colunas Truss fabricadas em alumínio, em cor prateada, com tubos de 32mm de diâmetro. Ideal para a realização e montagem de stands, cenários, eventos ao ar livre, colocação de lonas, entre outros. Caracteriza-se pela sua grande resistência, peso ligeiro e fácil montagem.

 Largueros de Truss, fabricados en aluminio, color "plata natural", con tubos de 32mm de diámetro. Ideal para realización y montaje de stands, escenarios, eventos al aire libre, colocación de lonas, etc. Se caracteriza por su gran resistencia, peso ligero y fácil montaje.





			L	
15.301	500x250mm		500mm	
15.302	750x250mm		750mm	
15.141	1000x250mm		1000mm	
15.143	1500x250mm		1500mm	
15.145	2000x250mm		2000mm	
15.303	2500x250mm		2500mm	
15.304	3000x250mm		3000mm	

Connector Truss

 4-Punkt-Winkel von Truss aus silberfarbenem Aluminium.

 Connector aluminium Truss. Color "natural silver".

 Cube pour l'union de colonnes de Truss. Fabriqué en aluminium et de couleur "argent naturel".

 Cubos de união para colunas Truss. Fabricados em alumínio em cor prateada.



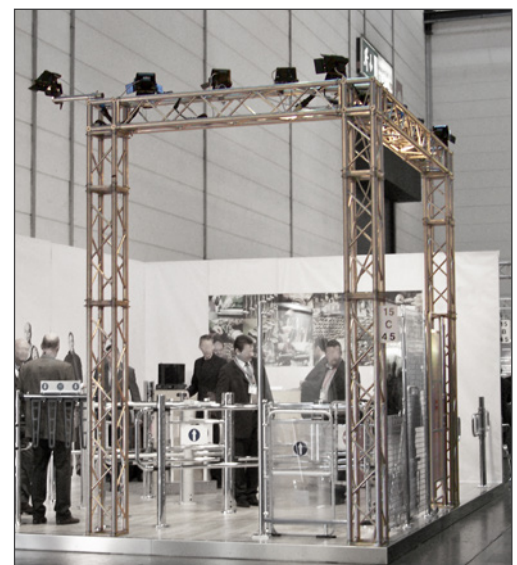
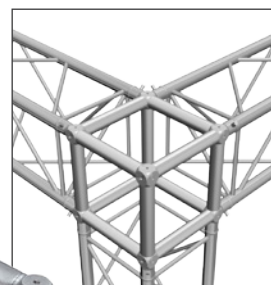

 Cubos para unión de largueros de Truss. Fabricados en aluminio y color "plata natural".



15.147	250x250x250mm	
--------	---------------	---

Accessories to connecting Truss "Show"

Conical Connector

-  Konusverbinder.
-  Conical connector.
-  Connecteur conique pour l'union de barres de Truss.
-  Conector cónico para unión de columnas Truss.
-  Conector cónico para unión de barras de Truss.



15.148





Pin

-  Bolzen.
-  Pin.
-  Goupille.
-  Passador.
-  Pasador.



15.149

Base for Aluminium Truss "Show"





-  Sicherungssplint R-Clip.
-  Steel base for aluminium Truss.
-  Base en acier pour Truss d'aluminium.
-  Base em aço para Truss de alumínio.
-  Base de acero para Truss de aluminio.



15.300 300x300mm



Half Conical Connector

-  Halbkonusverbinder.
-  Half conical connector. Aluminium + bolt.
-  Semi-connecteur conique pour l'union de barre de Truss + vis.
-  Semi-conector cónico com parafuso para unión de columnas Truss.
-  Semiconector cónico para unión de barras de Truss + tornillo.



15.151

Safety Clip

-  Sicherungssplint R-Clip.
-  Safety clip.
-  Clip de sécurité.
-  Clip de segurança.
-  Clip de seguridad.



15.150

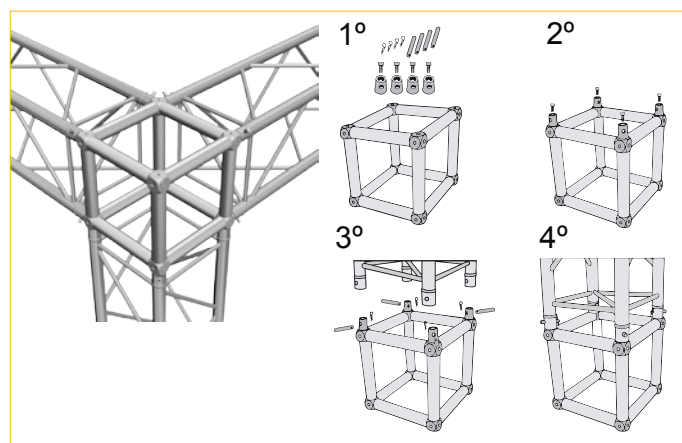
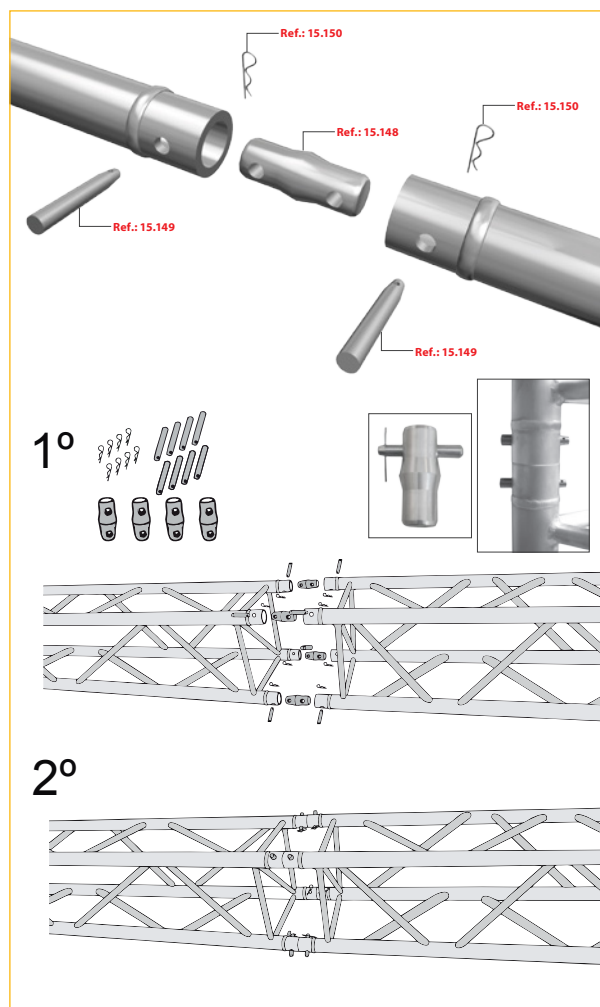



FLOOR SYSTEM

2

Floor System

 Bodenplatte mit Nut-und Feder-Panels mit Grafikträger. Verschiedenen Farben. Kunststoff.

 System platform using tongue and groove panels with graphic carrier. Available in different colours. Plastic.

 Système de sol modulable, facile et rapide à monter. Plusieurs couleurs disponibles.

 Sistema de solo modular, de fácil e rápida montagem. Disponível em várias cores.

 Sistema de suelo modular fácil y rápido de montar. Disponible en varios colores.

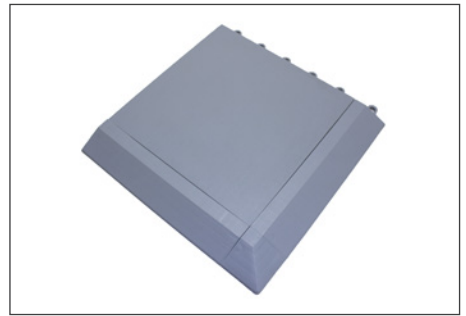
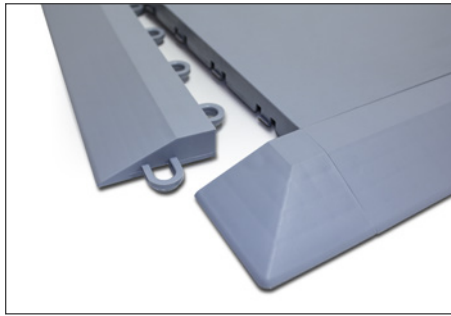
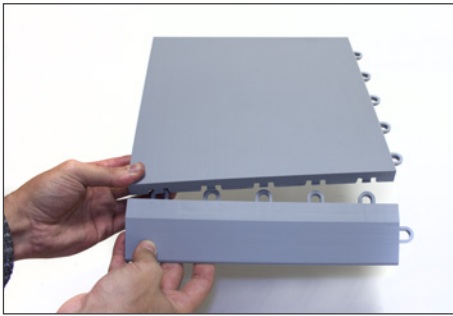
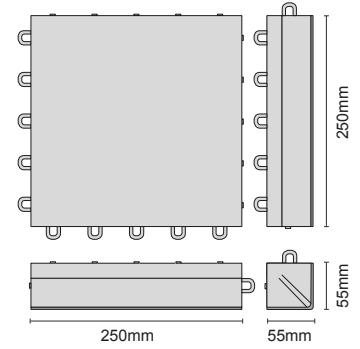
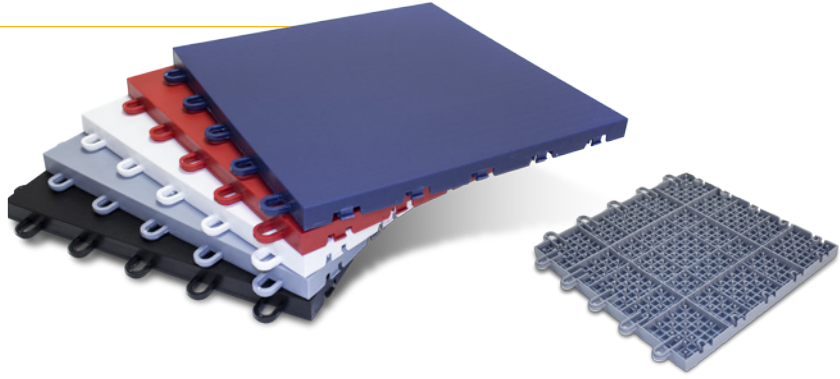

FLOOR SYSTEM

Colour Floor System

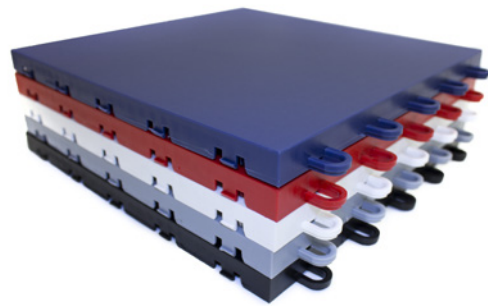
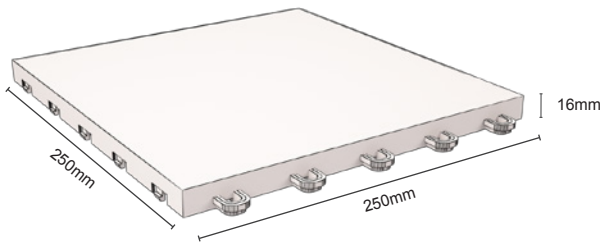
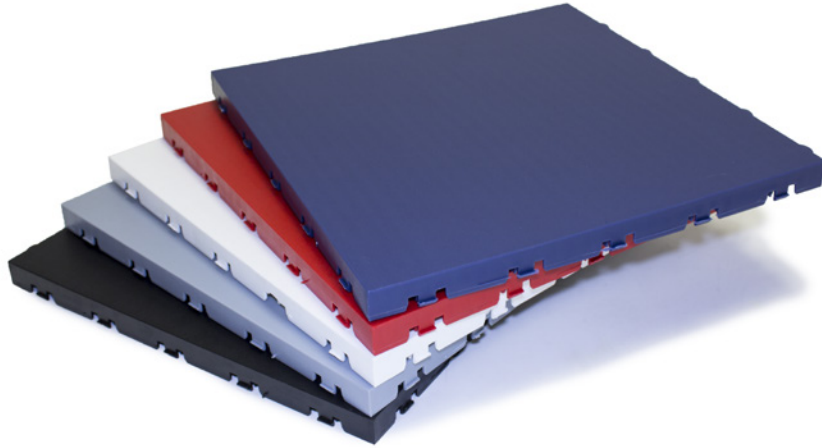

Farbe / Colour / Couleur / Cor / Color: ■ ■ ■ ■ ■

15.209

x16 (1 m²)

Floor System Frame and Corner

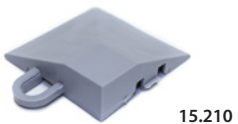

15.210

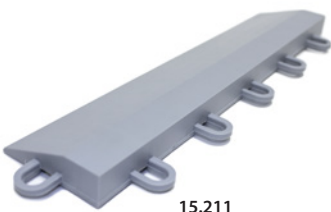
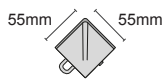

15.211

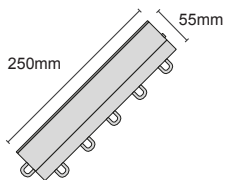

15.212

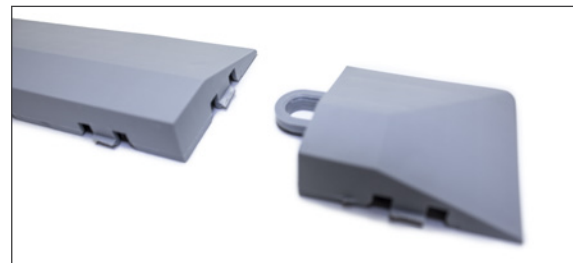
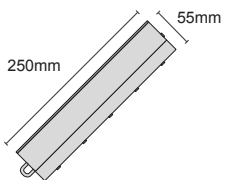

Farbe / Colour / Couleur / Cor / Color: ■ ■ ■ ■ ■

15.210

Corner

x4

15.211

Frame Male

x8

15.212

Frame Female

x8

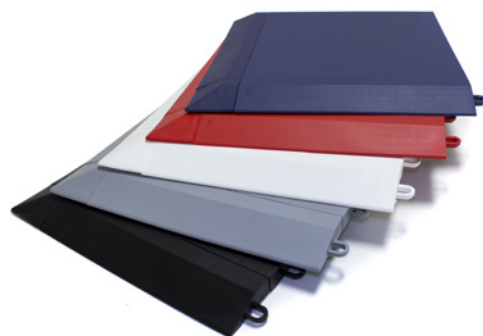

EXHIBITION FURNITURE

2

Swan

Hohe Barhocker aus ABS- Kunststoff und verchromtem Struktur.

High Bar stool made of ABS plastic and chromed structure.

Tabouret en plastique ABS avec structure finition chromée.

Banco alto fabricado em ABS com estrutura cromada.

Taburete alto fabricado en plástico ABS y estructura cromada.



36.031

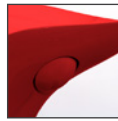

	QTY	N.W	C.B.M.	Size(mm)
Packing	2	13.5	0.100	415x410x590

36.030

36.031



Stylus

Hohe Barhocker aus ABS- Kunststoff und verchromtem Struktur.

High Bar stool made of ABS plastic and chromed structure.

Tabouret en plastique ABS avec structure finition chromée.

Banco alto fabricado em ABS com estrutura cromada.

Taburete alto fabricado en plástico ABS y estructura cromada.



36.028

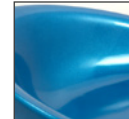

	QTY	N.W	C.B.M.	Size(mm)
Packing	2	13.6	0.112	460x415x590

36.028

36.029



VanDick

Hohe Barhocker aus ABS- Kunststoff und verchromtem Struktur.

High Bar stool of chromed structure and ABS plastic seat.

Tabouret fabriqué en plastique, avec piston à gaz, repose-pieds et structure chromée.

Banco alto fabricado em ABS com estrutura cromada

Taburete alto fabricado en plástico ABS y estructura cromada.



31.063

	QTY	N.W	C.B.M.	Size(mm)
Packing	2	14.8	0.076	420x350x520

31.047

31.063



31.047

Borneo

Hohe Barhocker aus ABS- Kunststoff und verchromtem Struktur.

Chair gray structure folding and wooden seat.

Tabouret pliable avec structure en métal et assise en bois.

Banco alto desdobrável com estrutura metálica de cor cinzenta e assento de madeira.

Taburete plegable de estructura metálica gris y asiento de madera.



36.018

	QTY	N.W	C.B.M.	Size(mm)
Packing	4	13	0.112	500x230x980

36.018



Renoir

Hohe Barhocker aus verchromten Struktur und ABS-Kunststoffsitz . Druckhebel für die Höhenverstellung.

High Bar stool of chromed structure and ABS plastic seat. Pressure lever for height adjustment.

Tabouret fabriqué en plastique, avec piston à gaz, repose-pieds et structure chromée.

Banco alto de plástico com estrutura cromada. Sistema de elevação a gás.

Taburete alto fabricado en plástico y estructura cromada. Sistema de elevación a gas.



31.034

Monet

Hohe Barhocker aus verchromten Struktur und ABS-Kunststoffsitz . Druckhebel für die Höhenverstellung.

High Bar stool of chromed structure and ABS plastic seat. Pressure lever for height adjustment.

Tabouret fabriqué en plastique, avec piston à gaz, repose-pieds et structure chromée.

Banco alto de plástico com estrutura cromada. Sistema de elevação a gás.

Taburete alto fabricado en plástico y estructura cromada. Sistema de elevación a gas.



31.033

	QTY	N.W	C.B.M.	Size(mm)
Packing	2	13	0.165	575x480x600

31.034



31.035



31.036

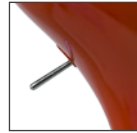
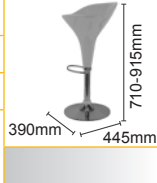

31.035

	QTY	N.W	C.B.M.	Size(mm)
Packing	2	14.6	0.088	420x410x515

31.031



31.032



31.033



31.031

Tiepolo

Hohe Barhocker aus verchromten Struktur und ABS-Kunststoffsitz . Druckhebel für die Höhenverstellung.

High Bar stool of chromed structure and ABS plastic seat. Pressure lever for height adjustment.

Tabouret fabriqué en plastique, avec piston à gaz, repose-pieds et structure chromée.

Banco alto de plástico com estrutura cromada. Sistema de elevação a gás.

Taburete alto fabricado en plástico y estructura cromada. Sistema de elevación a gas.



31.044

Pissarro

Hohe Barhocker aus verchromten Struktur und Sitz mit Kunstleder. Druckhebel für die Höhenverstellung.

High Bar stool of chromed structure and seat with imitation leather. Pressure lever for height adjustment.

Tabouret fabriqué en simili-cuir avec piston à gaz, repose-pieds et structure chromée.

Banco alto de plástico com estrutura cromada. Sistema de elevação a gás.

Taburete alto fabricado en simil piel y estructura cromada. Sistema de elevación a gas.



31.073

	QTY	N.W	C.B.M.	Size(mm)
Packing	2	14.3	0.170	570x490x610

31.043



31.044



31.045

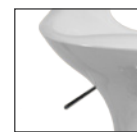

31.043

	QTY	N.W	C.B.M.	Size(mm)
Packing	1	8.98	0.074	470x280x565

31.073



31.074



31.074

Director

Germany Grauer Klappstuhl mit einer Sitzfläche aus Nylon.

UK Chair gray structure folding and Nylon seat.

France Chaise pliable. Assise en nylon.

Brazil Cadeira com estrutura, costas e assento em nylon.

Spain Silla de estructura plegable, respaldo y asiento de nylon.



36.026

	QTY	N.W	C.B.M.	Size(mm)
Packing	4	17.5	0.111	470x380x810

36.025



36.026



Mavick

Germany Grauer Klappstuhl mit einer Sitzfläche aus PVC.

UK Chair gray structure folding and PVC seat.

France Chaise pliable. Assise en PVC.

Brazil Cadeira com estrutura, costas e assento em PVC.

Spain Silla de estructura plegable, respaldo y asiento de PVC.



36.022



36.020

	QTY	N.W	C.B.M.	Size(mm)
Packing	6	22	0.113	450x280x900

36.020



36.022



Vives

Germany Stehtisch mit Chromrahmen und Holzbrett.

UK High table with chrome frame and wooden board.

France Table Haute avec structure chromée et plateau en bois.

Brazil Mesa alta com estrutura cromada e tampo de madeira.

Spain Mesa alta con estructura cromada y tablero de madera.



31.062

31.046

	QTY	N.W	C.B.M.	Size(mm)
Packing	1	10.57	0.096	620x170x620 180x180x965

31.046



31.062



Rubens

Germany Stehtisch. Ideal für Veranstaltungen und Ausstellungen. PVC und Chromstahl.

UK Bar table. Ideal for shows and exhibitions. PVC and steel chrome.

France Table de bar en PVC avec structure chromée.

Brazil Mesa alta com estrutura cromada e de PVC.

Spain Mesa alta con estructura cromada y PVC.



31.037

31.038

	QTY	N.W	C.B.M.	Size(mm)
Packing	1	8.1	0.108	620x200x620 180x180x990

31.038



31.037





CLICK FRAMES & BROCHURE STANDS

Aluminium Frames	166
Menu Board	181
Steel Frames	185
Steel Frames - PVC Board	187
Light Box	188
Brochure Stand	193

ALUMINIUM FRAMES

3

Lima

Robuster Rahmen aus eloxiertem Aluminium, für Wand- oder Deckenmontage. Optimale Grafikerhaltung durch Antireflexionskunststoff. Indoor-Bereich. Leichter Auf- und Abbau durch Klicksystem. Aufhänger inklusive.

Frames for wall mounting or suspended from the ceiling, made of anodized aluminum with high strength extruded molding. Includes anti-reflective plastic in front for better conservation of the graph. Suitable for indoor use. Easy assembly and disassembly thanks to its opening "click" system. Supplied with hangers.

Cadre en aluminium anodisé à fixer au mur ou à suspendre au plafond. Image facile à changer grâce au système d'ouverture click sur les quatre côtés. Utilisation intérieur. Accessoires de fixation et film antireflet inclus.

Marcos para parede ou para suspender do tecto, em alumínio anodizado bastante resistente. Fácil mudança de imagem devido ao sistema de abertura "click". Inclui película anti-reflexo e suspensores. Adequado para uso interior.

Marcos a pared o para suspender del techo, fabricados en aluminio anodizado con moldura extrusionada de gran resistencia. Incluye plástico anti-reflectante en su parte frontal para una mejor conservación de la gráfica. Adequado para uso interior. De fácil montaje y desmontaje gracias a su sistema de apertura "click". Se suministra con colgadores.



10.259



19mm

25mm

32mm

42mm

A4	A3	A2	A1	A0	500x700	700x1000	1000x1400	Size(mm)
10.210	10.209	10.208			10.211			19 10.4
10.260	10.259	10.258			10.261			25 11.5
	10.262	10.263	10.264		10.266	10.267		32 13.8
				10.270		10.272	10.268	42 13.8

Lima Double-Sided

Doppelseitiger Rahmen aus eloxiertem Aluminium für Deckenmontage. Optimale Grafikerhaltung durch Antireflexionskunststoff. Indoor-Bereich. Leichter Auf- und Abbau durch Klicksystem. Aufhänger inklusive.

Double-Sided Frames made to be hung from the ceiling, made of anodized aluminum with high strength extruded molding. Includes anti-reflective plastic in front for better conservation of the graph. Suitable for indoor use. Easy assembly and disassembly thanks to his opening "click" system. Supplied with hangers.

Cadre double face en aluminium anodisé à suspendre au plafond. Image facile à changer grâce à son système d'ouverture click sur les quatre côtés. Accessoires de suspension et film antireflet inclus. Résistant ce cadre est idéal pour une utilisation intérieur. Accessoires de fixation et film antireflet inclus.

Marcos dupla face para suspender do tecto, em alumínio anodizado bastante resistente. Fácil mudança de imagem devido ao sistema de abertura "click". Inclui película anti-reflexo e suspensores. Adequado para uso interior.

Marcos para suspender al techo a doble cara, fabricados en aluminio anodizado con moldura extrusionada de gran resistencia. Incluye plástico anti-reflectante en su parte frontal para una mejor conservación de la gráfica. Adequado para uso interior. Fácil montaje y desmontaje gracias a su sistema de apertura "click". Se suministra con colgadores.

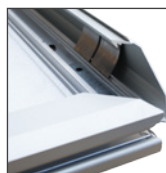

10.563



32mm

42mm

A3	A2	A1	A0	500x700	700x1000	Size(mm)
10.563	10.564	10.565		10.289		32 32.5
			10.257		10.560	42 32.5

Lima Lockable

Robuster Rahmen aus eloxiertem Aluminium, für Wand- oder Deckenmontage. Optimale Grafikerhaltung durch Antireflexionskunststoff. Indoor-Bereich. Leichter Auf- und Abbau durch Klicksystem. Verschlusschraube verhindert das Öffnen des Rahmens. Aufhänger inklusive.

Frames for wall mounting or suspended from the ceiling, made of anodized aluminum with high strength extruded molding. Includes anti-reflective plastic in front for better conservation of the graph. Indoor use. Easy assembly/disassembly thanks to his opening "click" system. One profile is closed with an Allen screw that locks the opening of the frame. Supplied with hangers.

Cadre en aluminium anodisé à fixer au mur ou à suspendre au plafond. Image facile à changer grâce au système d'ouverture click sur les quatre côtés. Utilisation intérieur. Blocage de l'ouverture du cadre par une vis Allen. Accessoires de fixation et film antireflet inclus.

Marcos para parede ou para suspender do tecto, em alumínio anodizado bastante resistente. Fácil mudança de imagem devido ao sistema de abertura "click". Inclui película anti-reflexo e suspensores. Adequado para uso interior. Um dos perfis fecha com um parafuso Allen que bloqueia a abertura do marco.

Marcos a pared o para suspender del techo, fabricados en aluminio anodizado con moldura extrusionada de gran resistencia. Incluye plástico anti-reflectante en su parte frontal para una mejor conservación de la gráfica. Adecuado para uso interior. Fácil montaje y desmontaje gracias a su sistema de apertura "click". Uno de los perfiles está cerrado con un tornillo Allen que bloquea la apertura del marco. Se suministra con colgadores.



10.282



A1	A0	500x700	700x1000	1000x1400	Size(mm)
10.280	10.281	10.282	10.283	10.278	42 13.8



Lima Waterproof

Robuster Rahmen aus eloxiertem Aluminium, für Wand- oder Deckenmontage. Optimale Grafikerhaltung durch Antireflexionskunststoff. In- und Outdoor-Bereich. Leichter Auf- und Abbau durch Klicksystem. Wasserdicht. Aufhänger inklusive.

Frames for wall mounting or suspended from the ceiling, made of extruded anodized aluminum offering a high resistance. Includes anti-reflective plastic in the front for better conservation of the graph. Suitable for exterior or interior use. Easy assembly and disassembly thanks to its opening "click" system on all four sides. Designed to prevent water going inside the frame. Supplied with hangers.

Cadre waterproof en aluminium anodisé à fixer au mur ou à suspendre au plafond. Image facile à changer grâce au système d'ouverture click sur les quatre côtés. Utilisation intérieur ou extérieur. Accessoires de fixation et film antireflet inclus.

Marcos para parede ou para suspender do tecto, em alumínio anodizado bastante resistente. Fácil mudança de imagem devido ao sistema de abertura "click". Inclui película anti-reflexo e suspensores. Adequado para uso interior ou exterior – elevado nível de resistência à água.

Marcos a pared o para suspender del techo, fabricados en aluminio anodizado con moldura extrusionada de gran resistencia. Incluye plástico anti-reflectante en su parte frontal para una mejor conservación de la gráfica. Adecuado para uso exterior o interior. Fácil montaje y desmontaje gracias a su sistema de apertura "click". Diseñado para permitir un alto nivel de resistencia al agua. Se suministra con colgadores.

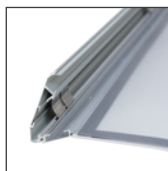

10.287

A1	A0	500x700	700x1000	1000x1400	Size(mm)
10.285	10.286	10.287	10.288	10.561	42 13.8



ALUMINIUM FRAMES

3

Anadia

Robuster Rahmen aus eloxiertem Aluminium, für Wand- oder Deckenmontage. Optimale Grafikerhaltung durch Antireflexionskunststoff. Indoor-Bereich. Leichter Auf- und Abbau durch Klicksystem. Aufhänger inklusive.

Frames for wall mounting or suspended from the ceiling, made of anodized aluminum with high strength extruded molding. Includes anti-reflective plastic in front for better conservation of the graph. Indoor use. Easy assembly/disassembly thanks to its opening "click" system. Supplied with hangers.

Cadre en aluminium anodisé à fixer au mur ou à suspendre au plafond. Image facile à changer grâce au système d'ouverture click sur les quatre côtés. Utilisation intérieur. Accessoires de fixation et film antireflet inclus.

Marcos para parede ou para suspender do tecto, em alumínio anodizado bastante resistente. Fácil mudança de imagem devido ao sistema de abertura "click". Inclui película anti-reflexo e suspensores. Adequado para uso interior.

Marcos a pared o para suspender del techo, fabricados en aluminio anodizado con moldura extrusionada de gran resistencia. Incluye plástico anti-reflectante en su parte frontal para una mejor conservación de la gráfica. Adecuado para uso interior. Fácil montaje y desmontaje gracias a su sistema de apertura "click". Se suministra con colgadores.

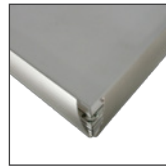

10.213

A4	A3	A2	A1	A0	500x700	700x1000	1000x1400	Size(mm)
10.314	10.315	10.316						19 12
10.214	10.213	10.212						25 12
	10.290	10.291	10.292					32 13.4
				10.296				42 14.5
					10.295	10.297		



19mm 25mm 32mm 42mm

Anadia Double-Sided

Doppelseitiger Rahmen aus eloxiertem Aluminium für Deckenmontage. Optimale Grafikerhaltung durch Antireflexionskunststoff. Indoor-Bereich. Leichter Auf- und Abbau durch Klicksystem. Aufhänger inklusive.

Frames made to be hung from the ceiling, double-sided, with easy exchange of graphic thanks to its opening "click" system on all four sides. Includes anti-reflective plastic in front for better conservation of the graph. Suitable for indoor use. Supplied with hangers. Material: Anodized aluminium.

Cadre double face en aluminium anodisé à suspendre au plafond. Image facile à changer grâce à son système d'ouverture click sur les quatre côtés. Accessoires de suspension et film antireflet. Résistant ce cadre est idéal pour une utilisation intérieure.

Marcos dupla face para suspender do tecto, em alumínio anodizado bastante resistente. Fácil mudança de imagem devido ao sistema de abertura "click". Inclui película anti-reflexo e suspensores. Adequado para uso interior.

Marcos para suspender al techo a doble cara, fabricados en aluminio anodizado con moldura extrusionada de gran resistencia. Incluye plástico anti-reflectante en su parte frontal para una mejor conservación de la gráfica. Adecuado para uso interior. Fácil montaje y desmontaje gracias a su sistema de apertura "click". Se suministra con colgadores.



10.299

A3	A2	A1	A0	500x700	700x1000	Size(mm)
10.299	10.300	10.302				32 32.5
			10.562		10.566	42 32.5

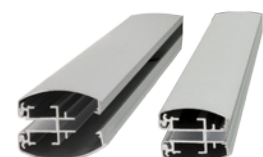

32mm 42mm

Serena

Robuster Rahmen aus eloxiertem Aluminium, für Wand oder Deckenmontage. Optimale Grafikerhaltung durch Antireflexionskunststoff. Indoor-Bereich. Leichter Auf- und Abbau durch Klicksystem. Aufhänger inklusive.

Frames for wall mounting or to be hung from the ceiling, double-sided, with easy exchange of graphic thanks to its opening "click" system on all four sides. Includes anti-reflective plastic in front for better conservation of the graph. Suitable for indoor use. Includes hanging accessories.

Cadre en aluminium anodisé à fixer au mur ou à suspendre au plafond. Image facile à changer grâce au système d'ouverture click sur les quatre côtés. Utilisation intérieur. Accessoires de fixation et film antireflet inclus.

Marco para parede ou tecto. A imagem muda-se facilmente devido ao seu sistema click. Inclui película anti-reflexo e suspensores. Pode ser utilizado no interior. Material: Alumínio Anodizado e plástico.

Marcos a pared o para suspender del techo, fabricados en aluminio anodizado con moldura extrusionada de gran resistencia. Incluye plástico anti-reflectante en su parte frontal para una mejor conservación de la gráfica. Adecuado para uso interior. Fácil montaje y desmontaje gracias a su sistema de apertura "click". Se suministra con colgadores.



32mm

A4	A3	A2	500x700	700x1000	Size(mm)
10.405	10.404	10.403	10.408	10.163	32
					13.4

Trujillo

Robuster Rahmen aus eloxiertem Aluminium, für Wand oder Deckenmontage. Optimale Grafikerhaltung durch Antireflexionskunststoff. Indoor-Bereich. Leichter Auf- und Abbau durch Klicksystem. Aufhänger inklusive.

Frames for wall mounting or ceiling suspension, made of extruded anodized aluminum, which offers a high resistance. Includes anti-reflective plastic on the front for better conservation of the graph. Suitable for interior use. Easy assembly/disassembly thanks to its opening "click" system. Supplied with hangers.

Cadre, en aluminium anodisé et angles en plastique, à fixer au mur ou à suspendre au plafond. Image facile à changer grâce au système d'ouverture click sur les quatre côtés. Utilisation intérieur. Accessoires de fixation et film antireflet inclus.

Marcos de grande resistência para parede ou para suspender do tecto. Fácil mudança de imagem devido ao sistema de abertura "click". Inclui película anti-reflexo e suspensores. Adequado para uso interior. Alumínio anodizado e plástico.

Marcos a pared o para suspender del techo, fabricados en aluminio anodizado con moldura extrusionada de gran resistencia. Incluye plástico anti-reflectante en su parte frontal para una mejor conservación de la gráfica. Adecuado para interior. Fácil montaje y desmontaje gracias a su sistema de apertura "click". Se suministra con colgadores.



32mm

A3	A2	A1	A0	500x700	700x1000	Size(mm)
10.131	10.132	10.133	10.134	10.135	10.136	32
					19.5	





*Farben Blau, Rot, Grün oder Braun auf Anfrage erhältlich.
Colours blue, red, green or wood available by request.
Couleurs : bleu, rouge, vert ou bois, disponibles sur demande.
Cores azul, vermelho, verde ou madeira disponíveis mediante consulta.
Colores azul, rojo, verde y madera disponibles bajo pedido.

ALUMINIUM FRAMES

3

Lublin

 Rahmen aus eloxiertem Aluminium für Wandmontage, optimale Grafikerhaltung durch Antireflexionskunststoff, Rahmenöffnung an der engeren Seite.

 Frames made of anodized aluminum wall. Includes anti-reflective plastic in front for better conservation of the graph. Strong and durable. Opening on the smaller side of the frame.

 Cadre en aluminium anodisé à fixer au mur ou à suspendre au plafond. Image facile à changer grâce au système d'ouverture click sur les quatre côtés. Utilisation intérieur ou extérieur. Accessoires de fixation et film antireflet inclus.

 Marcos de grande resistência para parede. Fácil mudança de imagem por uma das laterais. Película anti-reflexo. Material: alumínio anodizado.

 Marcos a pared fabricados en aluminio anodizado. Incluye plástico anti-reflectante en su parte frontal para una mejor conservación de la gráfica. Apertura por lado de menor tamaño (lado corto).

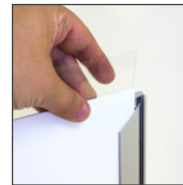

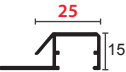
A4	A3	A2	A1	Size(mm)
10.594	10.593			
		10.588	10.587	

Gavarnie

 Aluminium-Ausstellungsrahmen mit Kunststoffklammern um die Grafik zu befestigen. Inklusive zwei Aufhänger.

 Exhibition frame for graphics. Frame made of aluminum and plastic clips to hold the graphic in its correct place. Includes two hanging pieces. Material: Aluminium, plastic parts.

 Cadre en aluminium avec des clips en plastique pour la fixation du visuel. Crochets inclus.

 Perfil de alumínio com clips de plástico para fixar a imagem. Inclui suspensores. Material: Alumínio e plástico.

 Sistema de exposición de gráficas realizado en aluminio y "clips" de plástico para la sujeción de las mismas. Incluye dos colgadores.

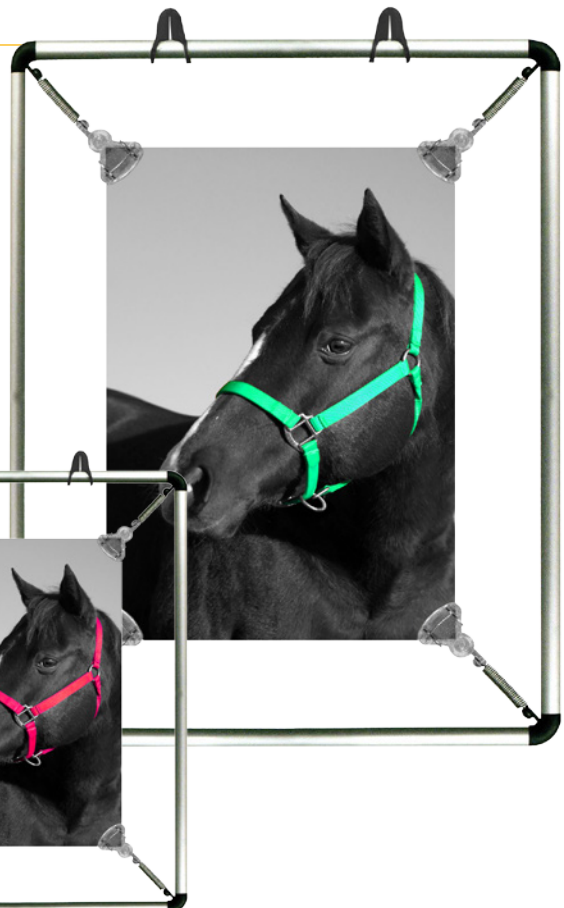

A4	A3	A2	A1	A0
10.508	10.507	10.506	10.505	10.509

Bayonne

 Doppelseitiger Kundenstopper aus Aluminium. In- und Outdoor-Bereich.

 Double-Sided snapframe used for poster presentation or graphics. Includes anti-reflective plastic. Suitable for indoor or outdoor use. Made of aluminum.

 Chevalet double face en aluminium. Idéal pour une utilisation intérieure ou extérieure.

 Cavalete de alumínio de dupla face. Inclui película anti-reflexo. Pode ser usado no interior ou exterior. Material: alumínio e plástico.

 Caballete a doble cara para gráfica. Adecuado para uso exterior o interior. Fabricado en aluminio.



10.804

500x700mm



Antireflection Sheet

 Antireflexionskunststoff für Klapprahmen.

 Antireflection sheet for snapframe.

 Antireflet pour cadres ou chevalets.

 Película anti-reflexo para marcos e cavaletes.

 Antireflex para marcos y cabaletes.



10.805

700x1000mm



10.952

500x700mm

10.953

700x1000mm

10.992

A1 - 598x838mm

10.993

A0 - 838x1188mm

13.145

A1



13.146

A0

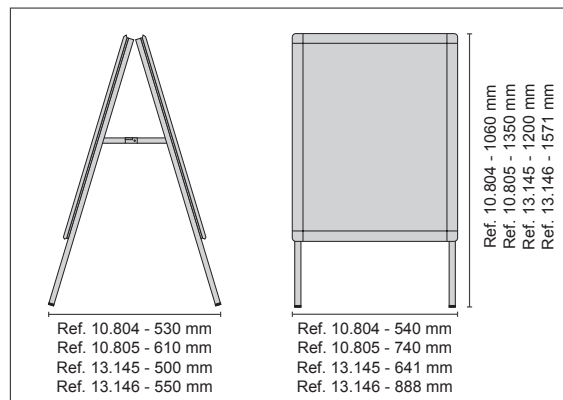

ALUMINIUM FRAMES

3

Niza

- Aluminium-Kundenstopper, einseitig, In- und Outdoor-Bereich.
- One sided anodized aluminium frame for wall mounting. Includes anti-reflective plastic. Suitable for indoor or outdoor use.
- Chevalet en aluminium. Idéal pour une utilisation intérieure ou extérieure. Antireflet inclus.
- Cavalete de alumínio de uma face. Inclui película anti-reflexo. Pode ser usado no interior ou exterior. Material: alumínio e plástico.
- Caballete de aluminio a una cara para gráfica promocional. Acabado para uso interior o exterior.

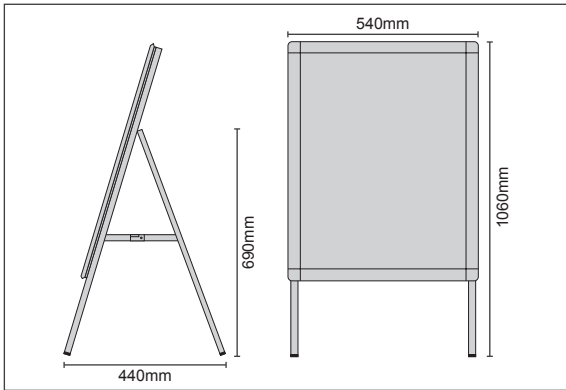

10.808 500x700mm



32mm

ECONOMIC!

CLICK!
System



Merida

- Doppelseitiger Aluminium-Kundenstopper. In- und Outdoor-Bereich. Verfügbar in verschiedene Farben.
- Double-sided frame for graphic or poster presentation. Includes anti-reflective plastic. Suitable for indoor or outdoor use. Made in aluminium and plastic parts.
- Chevalet double face en aluminium. Idéal pour une utilisation intérieure ou extérieure.
- Cavalete de alumínio de dupla face. Inclui película anti-reflexo. Pode ser usado no interior ou exterior. Material: alumínio e plástico.
- Caballete a doble cara, para gráfica. Adecuado para exterior o interior. Fabricado en aluminio.



A1	500x700	700x1000
10.337	10.338	10.339

CLICK!
System



32mm



*Farben Blau, Rot, Grün oder Braun auf Anfrage erhältlich.
Colours blue, red, green or wood available by request.
Couleurs : bleu, rouge, vert ou bois, disponibles sur demande.
Cores azul, vermelho, verde ou madeira disponíveis mediante consulta.
Colores azul, rojo, verde y madera disponibles bajo pedido.

Grenoble

Doppelseitiger Aluminium-Kundenstopper. In- und Outdoor-Bereich.

Double-Sided Aluminium frame used for graphics or poster presentation. Suitable for indoor or outdoor use.

Chevalet double face en aluminium avec angles en plastique. Idéal pour une utilisation intérieure ou extérieure. Antireflet inclus.

Cavalete de alumínio de dupla face. Inclui película anti-reflexo. Pode ser usado no interior ou exterior. Material: alumínio e plástico.

Caballete a doble cara, para gráfica. Adecuado para exterior o interior. Fabricado en aluminio.

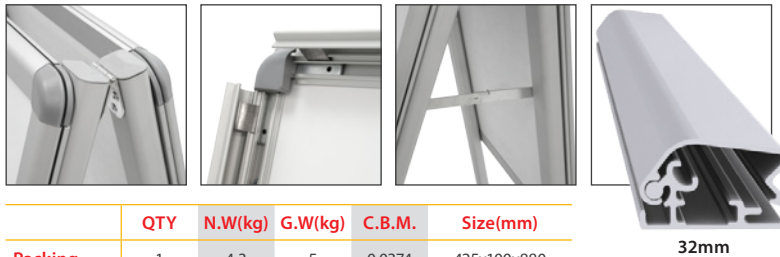
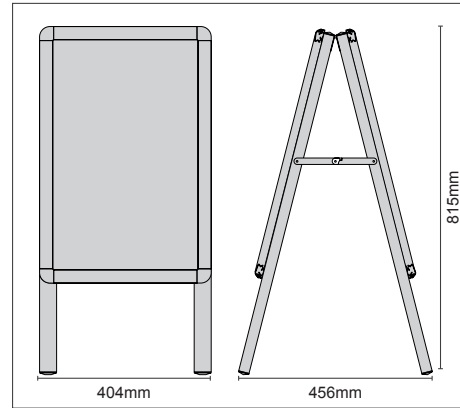

	QTY	N.W(kg)	G.W(kg)	C.B.M.	Size(mm)
Packing	1	4.3	5	0.0374	425x100x880

10.942

360x560mm



Poznan

Doppelseitiger Aluminium-Kundenstopper. In- und Outdoor-Bereich. Verfügbar in verschiedene Farben.

Double-Sided Aluminium frame used for graphics or poster presentation. Suitable for indoor or outdoor use.

Chevalet double face en aluminium avec angles en plastique. Idéal pour une utilisation intérieure ou extérieure. Antireflet inclus.

Cavalete de alumínio de dupla face. Inclui película anti-reflexo. Pode ser usado no interior ou exterior. Material: alumínio e plástico.

Caballete a doble cara, para gráfica. Adecuado para exterior o interior. Fabricado en aluminio.

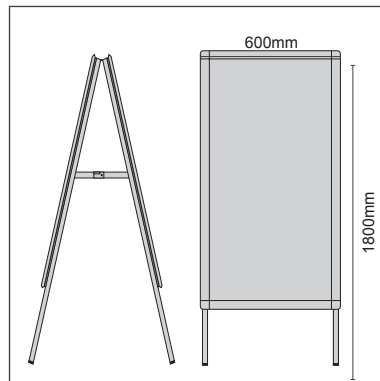

	QTY	N.W(kg)	G.W(kg)	C.B.M.	Size(mm)
Packing	1	12.6	15	0.177	705x135x1860

10.343

600x1500mm



ALUMINIUM FRAMES

3

Belmez

 Doppelseitiger Kundenstopper aus Aluminium und perforiertem Stahlblech. Grafikgröße DIN A1, inklusive Topschild 600x200mm.

 Double-sided frame with durable aluminium clip frame steel feet. Poster or sheets are protected by a thin anti-reflex cover for a better quality look. Headboard included. Dimension: A1. Headboard size: 600x200mm.

 Chevalet double face. Fabriqué en aluminium et plaque en acier perforée. Support supérieur pour visuel inclus (600mmx200mm). Dimensions A1.

 Cavalete de alumínio de dupla face. Inclui película anti-reflexo e suporte para cartaz superior 600x200 mm. Pode ser usado no interior ou exterior. Alumínio, aço e plástico.

 Caballete a doble cara para gráfica. Fabricado en aluminio y chapa perforada de acero. Incluye soporte para cartel superior: 600x200mm. Medida A1.

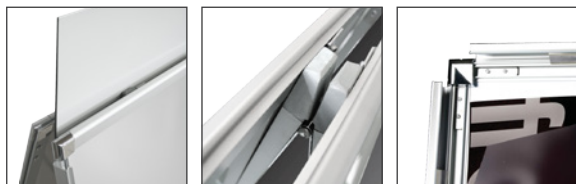
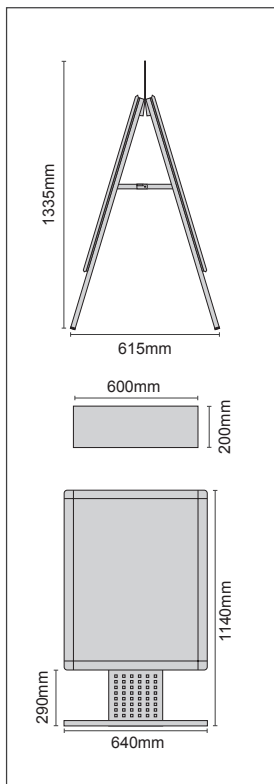

10.235

A1



Montanchez

 Doppelseitiger Kundenstopper, Aluminiumrahmen auf Stahlgestell. Rutschfest und verstellbare Füße. Aufgrund seines Gewichtes besonders für Outdoor geeignet.

 Double-sided snapframe for graphics. Suitable for exterior or interior use. Made of aluminum on steel structure. This display is very suitable for outdoors where its extra weight is needed. It features non-slip leveling feet.

 Chevalet pliant double face. Fabriqué en aluminium sur une structure en acier. Idéal pour intérieur ou extérieur grâce à son poids supplémentaire. Pieds antidérapants réglables.

 Cavalete de alumínio de dupla face. Inclui película anti-reflexo. Pode ser usado no interior ou exterior. Material: alumínio e plástico.

 Caballete plegable a doble cara, para gráfica. Adecuado para exterior o interior. Fabricado en aluminio sobre estructura de acero. Este display es muy apropiado para exteriores donde su peso extra es necesario. Cuenta con patas niveladoras antideslizantes.

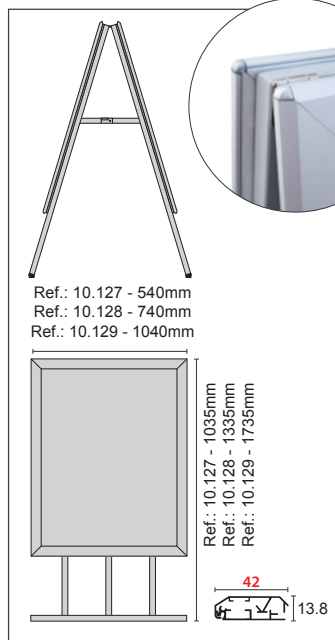
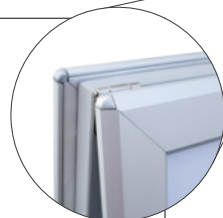

10.127

500x700mm



10.128

700x1000mm



10.129

1000x1400mm



Toulouse

Deutschland: Doppelseitiger Aluminium Kundenstopper. Klicksystem. Grafikgröße: 500x700mm. Grafikgröße Topschild: 500x200mm. Inklusive Prospektkorb aus Metall.

United Kingdom: Double-sided, frame announcement board with durable aluminium clip frame. Includes two frames of 500x700mm and two headframes of 500x200mm. Poster or sheets are protected by a thin anti-reflex cover.

France: Chevalet double face en aluminium avec un cadre Click inférieur de 500x700mm et un supérieur de 500x200mm. Porte brochure métallique inclus.

Portugal: Cavalete de alumínio de dupla face. Possui um marco inferior de 500x700mm e um superior de 500x200mm. Inclui película anti-reflexo. Inclui suporte metálico para folhetos. Material: alumínio e plástico.

Spain: Caballete a doble cara para gráfica. Fabricado en aluminio. Dispone de marco "Click" de 500x700mm y uno superior de 500x200mm. Incluye soporte portafolletos metálico.

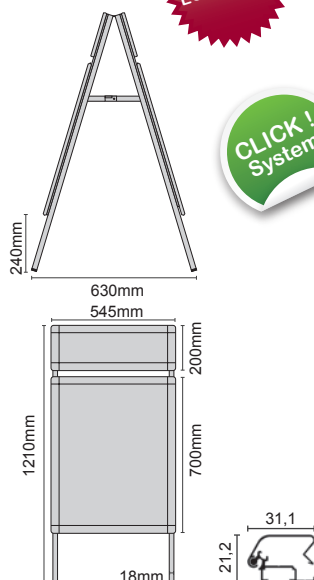

* Inklusiv.
Included.
Inclus.
Incluido.
Incluido.

10.806

500x700mm
500x200mm



Dijon

Deutschland: Aluminium Kundenstopper, einseitig, In- und Outdoor-Bereich.

United Kingdom: Double-sided snapframe for graphics. Suitable for exterior or interior use. Made of aluminum and plastic parts.

France: Chevalet double face en aluminium. Idéal pour une utilisation intérieure ou extérieure.

Portugal: Cavalete de alumínio de dupla face. Inclui película anti-reflexo. Material: alumínio e plástico.

Spain: Caballete a doble cara para gráfica. Adecuado para uso exterior o interior. Fabricado en aluminio.

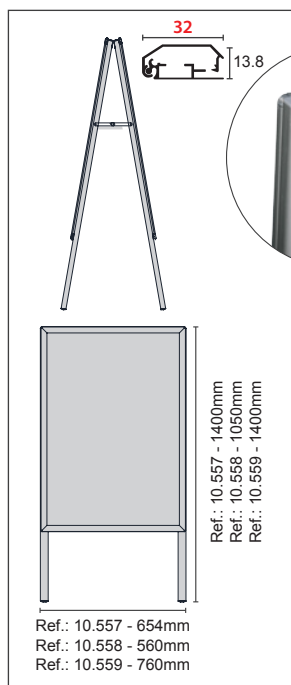

10.557

A1



10.558

500x700mm



10.559

700x1000mm



ALUMINIUM FRAMES

3

Ibahernando

Schwingender Klapprahmen aus Aluminium, doppelseitig.

Revolving snapframe stand. Double-sided poster stand for outdoor use, aluminium frame, which swings back and forth. Material: Aluminium, plastic parts.

Chevalet basculant double face. Fabriqué en aluminium.

Cavalete de aluminio de dupla face. Inclui película anti-reflexo. Material: aluminio e plástico.

Soporte basculante a doble cara para gráfica. Fabricado en aluminio.

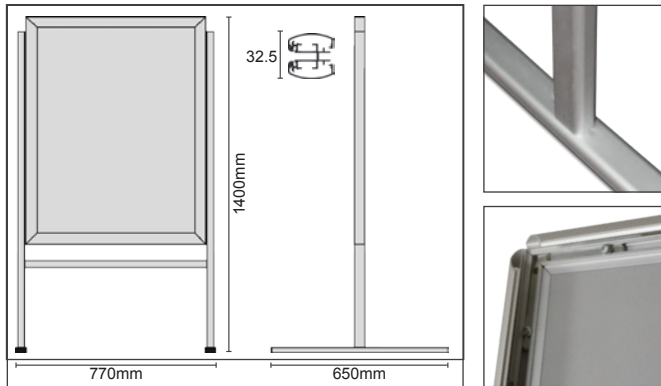

	QTY	N.W(kg)	G.W(kg)	C.B.M.	Size(mm)
Packing	1	9.6	11.8	0.141	875x105x1535

10.165

700x1000mm



32mm

Tilting

Almendralejo

Rahmen mit Rädern für den Transport und Prospekthalter Schalen Unterstützung. Hergestellt aus Aluminium. Erhältlich in den folgenden Konfigurationen Prospekthalter Schalen 6 A6 oder 4 Boxen A5 oder 3 Boxen A4.

Poster stand with leaflet dispensers. Made in aluminium. Available with the following brochure holders settings: 6 boxes A6 or 4 boxes A5 or 3 boxes A4.

Chevalet en aluminium pour une utilisation à l'intérieur. Disponible avec 6 porte brochures A6, ou 4 porte brochures A5 ou 3 porte brochures A4. Matériel: aluminium et plastique.

Expositor de aluminio com porta-folhetos disponível em simples ou dupla face. Adequado para interior. Disponível com 6 porta-folhetos A6, 4 porta-folhetos A5 ou 3 porta-folhetos A4. Material: alumínio e plástico.

Marco con ruedas para transporte y soporte portafolletos. Fabricado en aluminio. Disponible con las siguientes configuraciones de portafolletos: 6 cajetines A6 ó 4 cajetines A5 ó 3 cajetines A4.

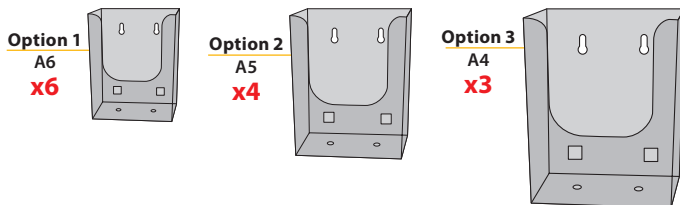

	QTY	N.W(kg)	G.W(kg)	C.B.M.	Size(mm)
Packing	1	7.5	12.1	0.125	860x75x1950

10.160

700x1000mm



10.759

700x1000mm



32mm

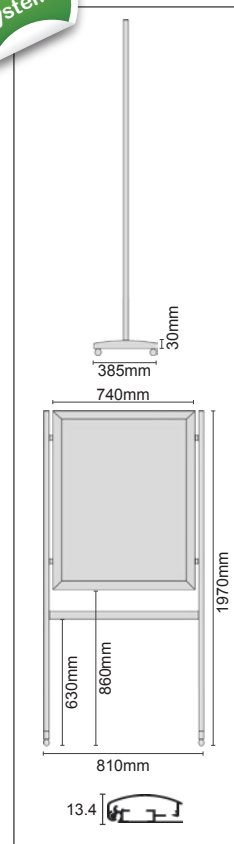

Boal

Doppelseitiger Aluminiumrahmen. Metallfedern zwischen Rahmen und FüÙe die Mobilität ermöglichen.

Double-sided aluminium snapframe for indoor or outdoor use. Highly effective advertising combined with stability via spring attachment of board to base.

Chevalet double face en aluminium. Ressorts métalliques, permettant l'oscillation du cadre, inclus.

Cavalete em alumínio de dupla face. Adequado para uso interior ou exterior. Elevada estabilidade devido às molas que unem o marco à base. Material: alumínio, aço e plástico.

Marco realizado en aluminio para uso doble cara que incluye muelles metálicos y patas que facilitan su movilidad.

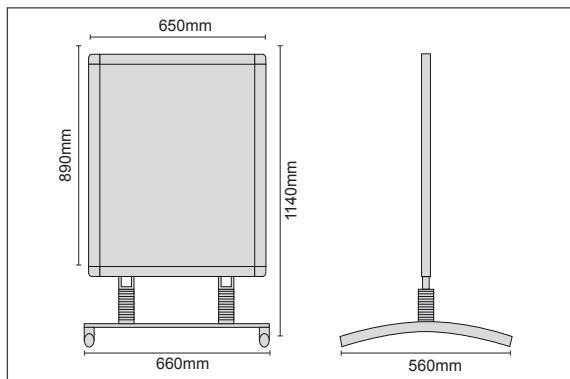

10.166 605x860mm



Hervas

Doppelseitiger Aluminiumrahmen. Metallfedern zwischen Rahmen und FüÙe, welche Mobilität ermöglichen.

Poster stand. Highly effective advertising combined with stability via spring attachment of board to base. Sturdy steel and aluminium construction ensures durability of this two sided stand.

Chevalet double face en aluminium et acier. Ce chevalet est fabriqué avec des ressorts pour faciliter l'oscillation et obtenir une meilleure résistance au vent.

Cavalete em alumínio e aço de dupla face. Elevada estabilidade e durabilidade devido à sua construção e às molas que unem o marco à base. Material: alumínio, aço e plástico.

Marco a doble cara para gráfica. Fabricado en aluminio. El display tiene muelles para facilitar la inclinación del marco que consiguen una menor resistencia al viento.

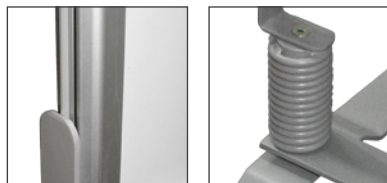
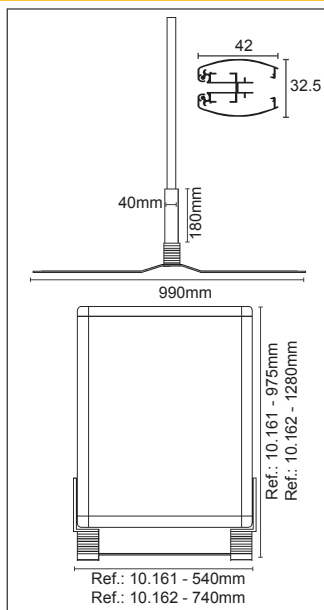

10.161 500x700mm

10.162 700x1000mm



ALUMINIUM FRAMES

3

Arcachon

Doppelseitiger Aluminiumrahmen mit Kunststofffuß, mit Wasser auffüllbar und Metallfedern.

Frame made from aluminum for double-sided use includes metal springs and refillable water based. Indoor and outdoor use.

Chevalet waterproof double face fabriqué en aluminium. Ressorts métalliques et base à remplir d'eau inclus. Utilisation intérieure ou extérieure.

Cavalete de alumínio de dupla face. Adequado para uso interior ou exterior. Elevada estabilidade devido às molas que unem o marco à base que se pode encher com água. Material: alumínio, aço e plástico.

Marco realizado en aluminio para uso doble cara que incluye muelles metálicos y base rellenable de agua.



WATERPROOF

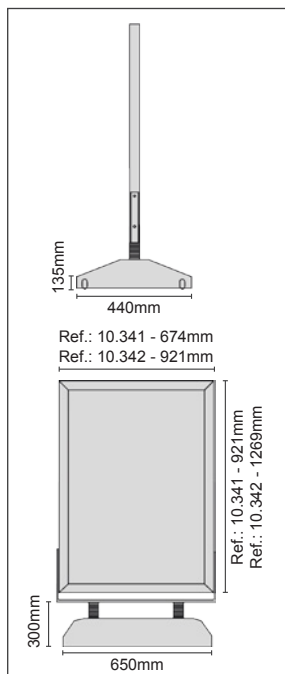
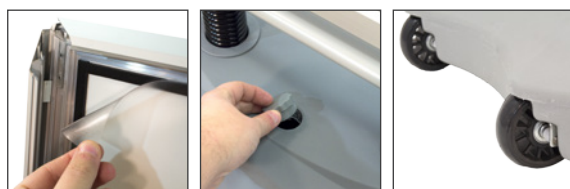

17 kg Water

42mm

10.341	A1		
10.342	A0		
10.115	500x700mm		
10.116	700x1000mm		

Serradilla

Doppelseitiger Aluminiumrahmen mit Kunststofffuß, mit Wasser auffüllbar und Metallfedern. Ideal für den Outdoor-Bereich.

Double-sided brushed aluminium display, with springs to facilitate the tilting of the frame. Plastic base to fill with water or sand. Ideal for outdoor use and strongly resistant to wind. Available for A0, A1 portrait snapframe.

Chevalet double face en aluminium, de taille A0 et A1. Fabriqué avec des ressorts pour faciliter l'oscillation et une base à remplir d'eau ou de sable. Idéal pour l'extérieur.

Cavalete de alumínio escovado de dupla face, disponível nos formatos A0 e A1. Resistente ao vento, revela uma grande estabilidade devido às molas que unem o marco à base. Esta base pode ser encheda com água ou areia. Material: alumínio, aço e plástico. Ideal para exterior.

Marco a dos caras para gráfica. Fabricado en aluminio. El display tiene muelles para facilitar la inclinación del marco. Base de plástico para rellenar de agua o arena. Ideal para exteriores.

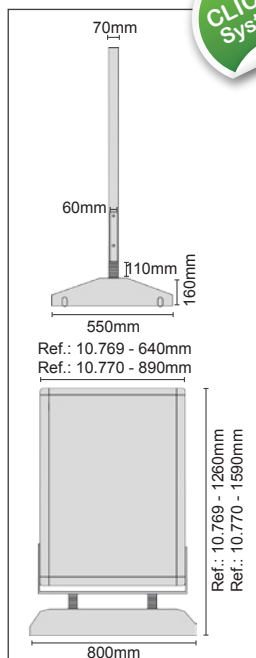

17-35 kg Water



10.769	A1	35 kg water	
10.770	A0	35 kg water	
10.164	A1	17 kg water	

Mota

Aluminiumrahmen für 4 Grafiken, einseitig. In- und Outdoor-Bereich.

Graphic Column with 4 frames, to one side. Suitable for exterior or interior. Material: Anodized aluminum.

Colonne de 4 cadres en aluminium, simple face. Idéal pour une utilisation intérieure ou extérieure.

Coluna em alumínio anodizado de uma face com 4 marcos para colocar impressão. Material: alumínio anodizado.

Columna gráfica con marcos, a una cara. Adecuado para exterior o interior. Fabricado en aluminio.

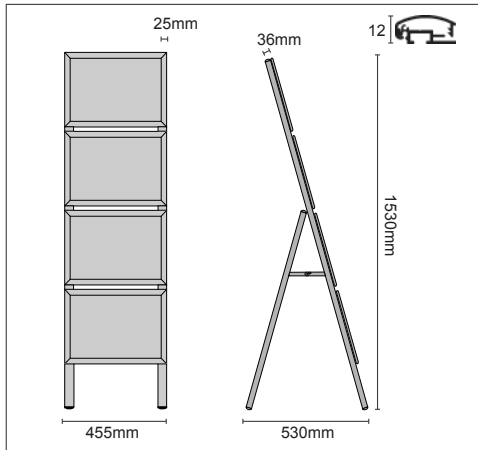

10.216

A3

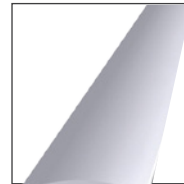
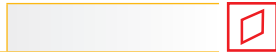

25mm



Guadalupe

Aluminiumrahmen mit Stahlbasis, ein- oder doppelseitig, für In- und Outdoor-Bereich. Grafikgröße DIN A4: 4 Rahmen. Grafikgröße DIN A3: 3 Rahmen.

Column graphic with frames, to one or two sides, using the "click system". Appropriate for exterior or interior. Made of aluminum on steel base. Size A4: consists of 4 frames, A3: consists of 3 frames.

Colonne en aluminium et acier, disponible avec 4 cadres en aluminium A4 ou 3 cadres en aluminium A3. Antireflet inclus.

Coluna em alumínio anodizado de uma ou duas faces (3 ou 6 marcos A3 / 4 ou 8 marcos A4) com base de aço. Inclui película anti-reflexo. Material: alumínio, aço e plástico.

Columna gráfica con marcos, a una o dos caras. Adecuado para exterior o interior. Fabricado en aluminio sobre base de acero. Tamaño A4: Se compone de 4 marcos, A3: Se compone de 3 marcos.

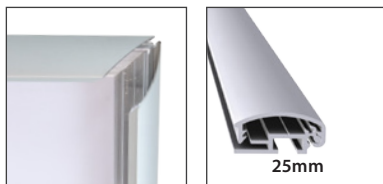

10.154

A4

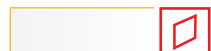

10.155

A3

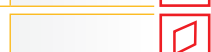

10.156

A4

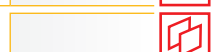

10.157

A3

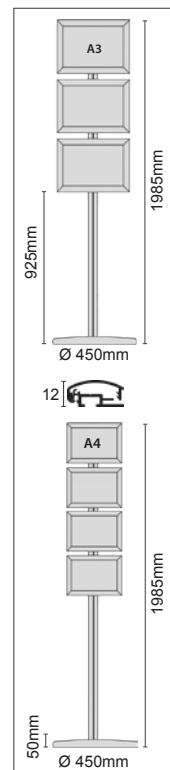
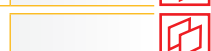

10 kg

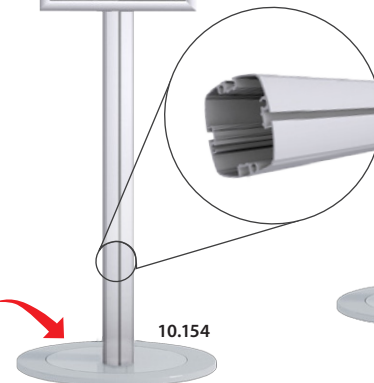

10.154

10.155

ALUMINIUM FRAMES

3

Plasencia

Aluminiumrahmen mit Stahlbasis, ein- oder doppelseitig, für In- und Outdoor-Bereich.

Graphic display for one or two sides, using the opening "click" system. Suitable for interior, although it can be used outdoors. Made of aluminum on steel base.

Totem en aluminium et acier, simple ou double face. Disponible en deux dimensions. Antireflet inclus.

Coluna em alumínio anodizado de uma ou duas faces com base de aço. Inclui película anti-reflexo. Material: alumínio, aço e plástico.

Display para gráfica a una o dos caras. Adecuado para interior, aunque puede usarse en exteriores. Fabricado en aluminio sobre base de acero.

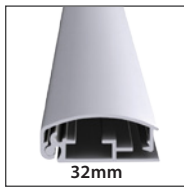
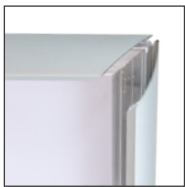

10.147	500x700		
10.148	700x1000		
10.151	500x700		
10.152	700x1000		

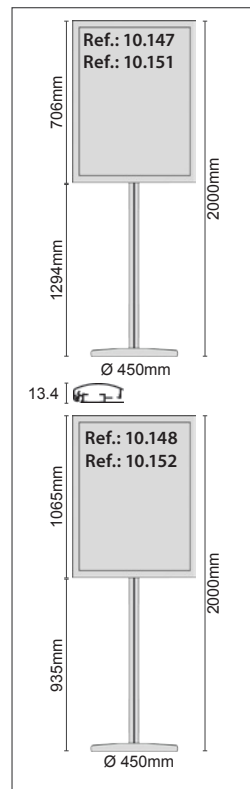

Leinster

Doppelseitiges Display mit Klicksystem, Aluminiumständer und Stahlbasis.

Double-Sided display for indoor use, using the opening "click" system. Includes aluminum stand with steel base.

Totem double face pour un affichage lumineux. Visuel facile à changer grâce à l'ouverture des profils latéraux. D'aspect élégant et de forme convexe, l'affiche reste au niveau des yeux.

Totem de dupla face para interior com sistema de abertura "click". Material: alumínio, aço e plástico.

Totem a doble cara con sistema "clic" de apertura. Incluye soporte de aluminio con base de acero.

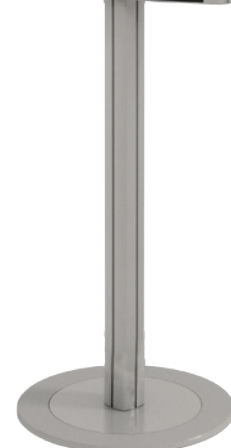
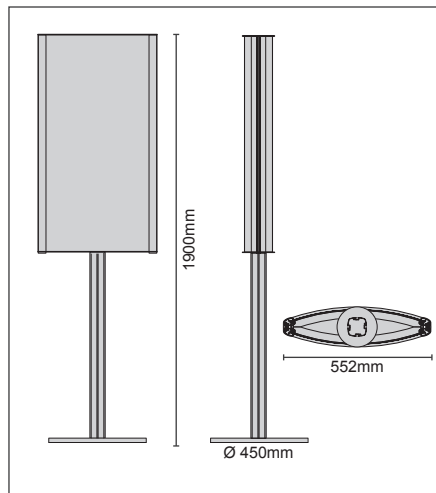
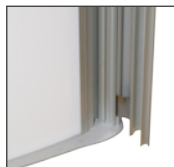

10.980	500x700mm		
10.979	500x1000mm		
10.940	500x700mm		
10.941	500x1000mm		

MENU BOARD

Ulster

- Aluminium Präsentationspult mit 2 Füßen für DIN A3 Grafiken.
- One sided menu board. Available in A3 size in landscape position. Material: Aluminium, plastic parts.
- Atril avec 2 mats et un cadre A3. Fabriqué en aluminium.
- Atril de uma face tamanho A3 horizontal com pé duplo. Fabricado em alumínio.
- Atril a una cara tamaño A3, para gráfica con doble mástil. Fabricado en aluminio.

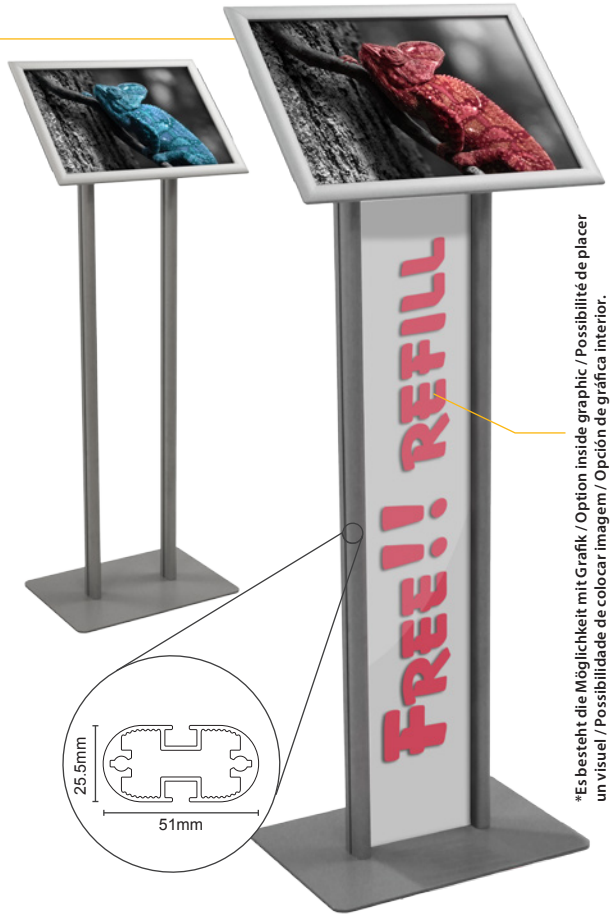
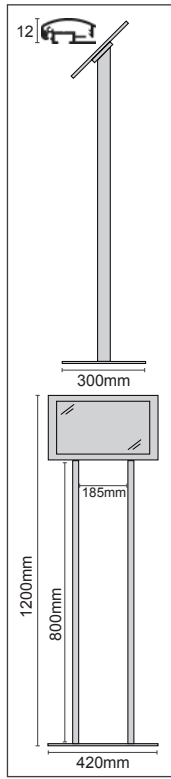
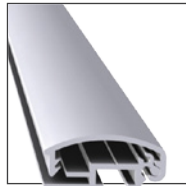

*Es besteht die Möglichkeit mit Grafik / Option inside graphic / Possibilité de placer un visuel / Possibilité de colocar imagen / Opción de gráfica interior.

10.982

A3



Zafra

- Aluminium Präsentationspult mit Kunststoffbasis, einseitig.
- One sided menu board. Available in A3 and A4 sizes, both in landscape and portrait positions. Material: Aluminium, plastic parts.
- Atril simple face avec cadre A4 ou A3. Fabriqué en aluminium et socle en acier.
- Atril de uma face tamanho A3 ou A4, horizontal ou vertical. Base em plástico. Material: alumínio e plástico.
- Atril a una cara, disponible en tamaño A3 o A4, ambos en horizontal o vertical. Fabricado en aluminio sobre base plástica.

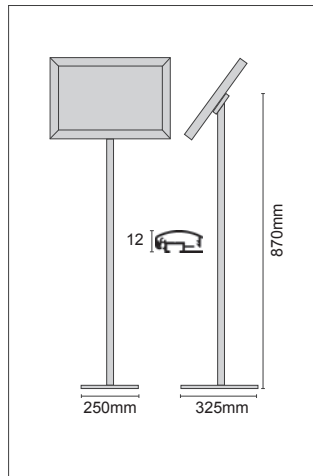

25mm



10.158

A4

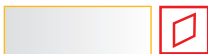

10.159

A3

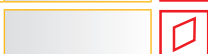



MENU BOARD

3

Sligo

 Menüboardsystem mit transparenten Acryl- oder Metallplatten. Mit einem Ringordner werden die Menüseiten zusammen gehalten. 2x A4 einzelnen Menüseiten.

 Acrylic or metallic menu board, with 2x A4 metal tray and rings. Allows the placement of catalogs and advertising.

 Atril avec lutrin en acrylique ou métal.

 Atril em alumínio com bandeja 2 x A4 em acrílico ou metal. Permite a colocação de catálogos e publicidade, entre outros, devido ao sistema de argolas.

 Atril en acrílico o metal, con bandeja 2x A4 y anillas. Permite la colocación de catálogos y publicidad.

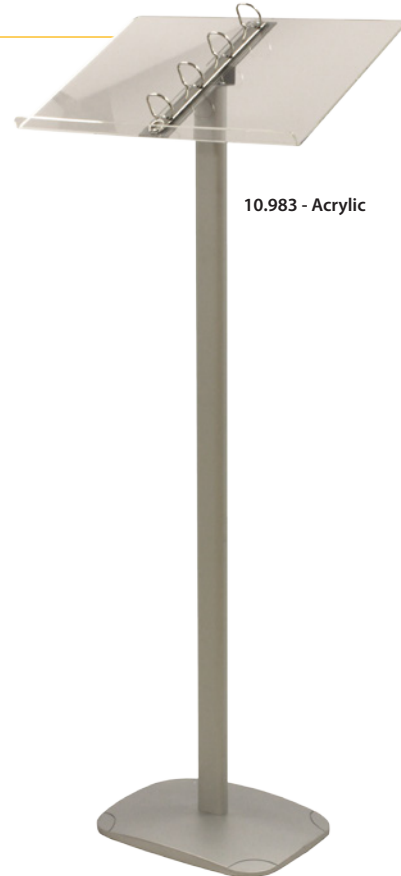
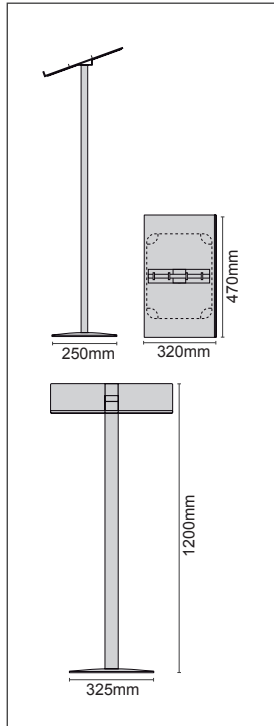

10.983 - Acrylic



10.984 - Metallic

10.984	Metallic	<input type="checkbox"/>
10.983	Acrylic	<input type="checkbox"/>

Solana

 Einstellbarer Dreifuß aus Aluminium, ideal für Rahmen-Aufstellung.

 Extendable tripod, made of aluminum. Ideal for placement of frames.

 Trépied extensible, en aluminium. Idéal pour y placer des cadres.

 Tripé ajustável e extensível em alumínio. Ideal para colocação de marcos.

 Trípode extensible, en aluminio. Ideal para la colocación de marcos.

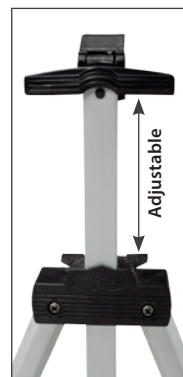
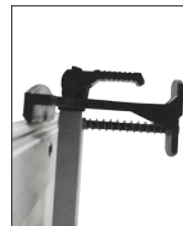
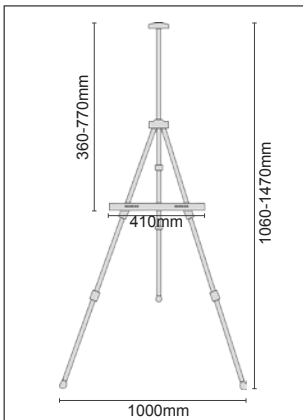

* Rahmen nicht enthalten.
Frame not included.
Cadre non inclus.
Marco não incluído.
Marco no incluido.

10.816



MENU BOARD

Combi



Prospekthalter aus Aluminium und Stahl, einfache Montage. Die „Combi“ Displays werden in kompletten Sets geliefert.

Full set of holders of easy assembly. The displays "Combi" are supplied in complete Kits. Made of aluminum and steel.

Support porte brochures en aluminium et métal. D'assemblage facile, plusieurs configurations sont possibles.

Sistema completo de porta-folhetos e/ou marcos de fácil montagem. Os display "Combi" fornecem-se em kits completos. Fabricados em alumínio e aço.

Sistema completo de portafolletos y/o portagráficas de fácil montaje. Los displays "Combi" se suministran en Kits completos y están realizados en aluminio y acero.

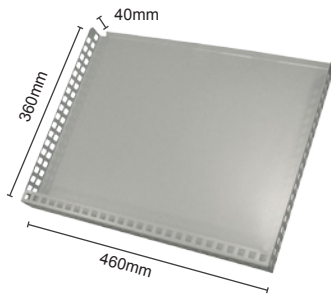

10.479 Combi One - 1

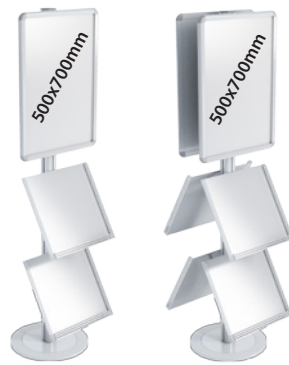

10.485 Combi Two - 1



10.483 Combi Three - 1



10.481 Combi Four - 1



10.487 Combi Mix - 1

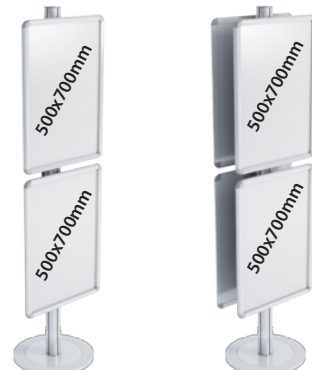

10.489 Combi Frame - 1

10.480 Combi One - 2

10.486 Combi Two - 2

10.484 Combi Three - 2

10.482 Combi Four - 2

10.488 Combi Mix - 2

10.490 Combi Frame - 2

MENU BOARD

3

Melgar

 Aluminium Präsentationspult, ein- oder doppelseitig.

 Showcard stand, can exhibit one or two graphics in portrait or landscape position. Material: Aluminium, plastic parts.



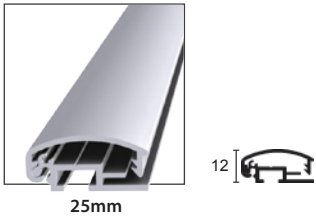

 Atril en aluminium en simple ou double face. Configuration horizontale ou verticale possible.

 Atril de alumínio de uma ou dupla face para colocação de impressão na horizontal ou vertical. Material: alumínio e plástico.



 Atril a una o dos caras para exposición de gráficas. Fabricado en aluminio.







10.344	A4		
10.579	A3		

10.349	A4	 x1 - A4	
10.583	A3	 x1 - A4	



10.345	A4		
10.580	A3		

10.549	A4	 x2 - A4	
10.584	A3	 x2 - A4	

Kerry

Doppelseitiger Kundenstopper aus lackiertem verzinktem Stahl. Magnetische Schutzabdeckung, In- und Outdoor-Bereich.

Double-sided frame, with magnetic protective cover. Suitable for areas of great affluence. Exterior and interior use. Made of lacquered galvanized steel.

Chevalet double face stable et lourd, avec une protection magnétique. Fabriqué avec des tubes ronds en acier.

Cavalete de dupla face com cobertura magnética protectora. Estável e firme, adequado para áreas movimentadas. Adequado para interior ou exterior. Material: aço galvanizado lacado.

Caballete portagráficas, doble cara, con cubierta magnética protectora. Adecuado para áreas con gran tránsito de público. Tanto para exterior como interior. Realizado en acero galvanizado lacado.

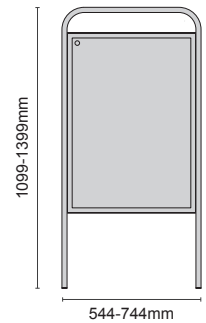
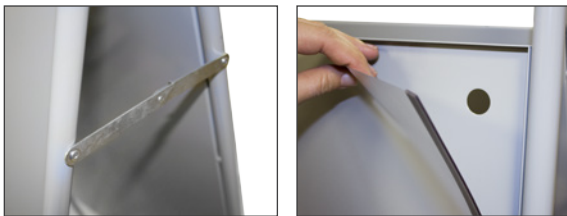

Farbe / Colour / Couleur / Cor / Color:

10.691	500x700mm	<input type="checkbox"/>	
10.692	700x1000mm	<input type="checkbox"/>	

Cork

Doppelseitiger Kundenstopper mit Topschild, stabil und fest, aus lackiert verzinktem Stahl. Magnetische Schutzabdeckung, für In- und Outdoor-Bereich.

Double-sided frame, with magnetic protective cover and top fitting. Suitable for areas of great affluence of people. Exterior and interior use. Made of lacquered galvanized steel.

Chevalet double face stable et lourd, avec une protection magnétique. Fabriqué avec des tubes ronds en acier.

Cavalete de dupla face e suporte superior com cobertura magnética protectora. Estável e firme, adequado para áreas movimentadas. Adequado para interior ou exterior. Material: aço galvanizado lacado.

Caballete estable y firme a doble cara con protector imantado y acople superior. Adecuado para áreas de gran afluencia. Tanto exterior como interior. Realizado en acero galvanizado lacado.

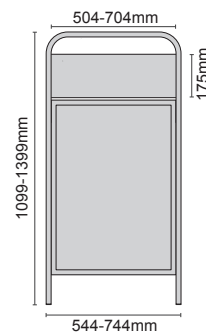
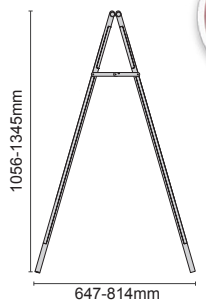
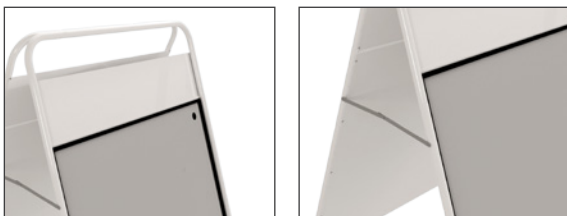

Farbe / Colour / Couleur / Cor / Color:

10.695	500x700mm - 175x504mm	<input type="checkbox"/>	
10.696	700x1000mm - 175x704mm	<input type="checkbox"/>	

STEEL FRAMES

3

Monaghan

DE Doppelseitiger Kundenstopper mit Topschild, stabil und fest, aus lackiert verzinktem Stahl. Magnetische Schutzabdeckung, für In- und Outdoor-Bereich.

UK Double-sided frame, with magnetic protective cover and top fitting. Suitable for indoor or outdoor crowded public places. Made of lacquered galvanized steel.

FR Chevalet double face, stable et fixe, avec une couverture protectrice aimantée. Fabrique en acier galvanisé laqué ce chevalet est idéal pour une utilisation intérieure ou extérieure.

PT Cavalete fabricado com tubo de aço, estável e pesado para uso em dupla face. Possui um acabamento magnético para colocar a imagem. Ideal para zonas movimentadas. Material: Aço e plástico.

ES Caballete estable y firme a doble cara con protector imantado y acople superior. Adecuado para áreas de gran afluencia. Tanto exterior como interior. Realizado en acero galvanizado lacado.

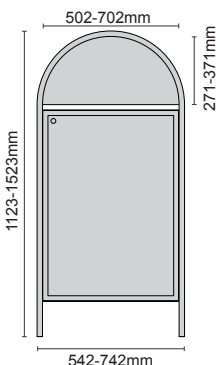

Farbe / Colour / Couleur / Cor / Color:

10.699 500x700mm - 514x256mm



10.700 700x1000mm - 714x357mm



Lifford

DE Doppelseitiger Kundenstopper, stabil und fest, aus lackiertem verzinktem Stahl. Magnetische Schutzabdeckung, für In- und Outdoor-Bereich.

UK Stable and firm frame, with magnetic protective cover and top fitting. Suitable for indoor or outdoor crowded public places.

FR Chevalet double face stable et lourd, avec une protection magnétique. Fabriqué avec des tubes ronds en acier.

PT Cavalete de dupla face com cobertura magnética protectora. Estável e firme, dequado para áreas movimentadas. Adequado para interior ou exterior.

ES Caballete estable y firme a doble cara con protector imantado. Adecuado para áreas de gran afluencia. Tanto exterior como interior.

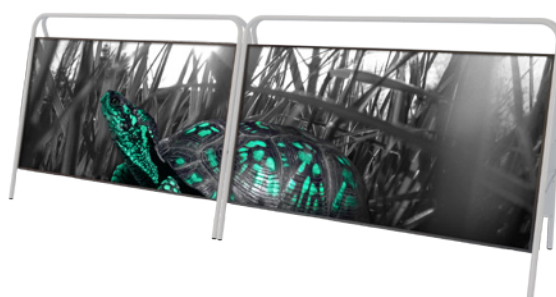
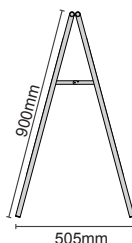
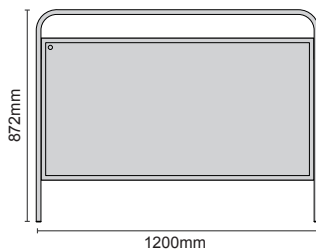

	QTY	N.W(kg)	G.W(kg)	C.B.M.	Size(mm)
Packing	1	15.7	17	0.0751	935x65x1235

10.701 1156x600mm



Outdoor Poster Stand

Outdoor Posterstand. Doppelseitiges Stahlprofil. Erhältlich in 6 verschiedenen Farben.

Outdoor poster stand. Double-sided stand steel profile. Available in six different colors.

Chevalet double face fabriqué en acier. Plusieurs couleurs disponibles. Plaques non incluses.

Cavalete de dupla face em aço pintado com epóxi para maior protecção. Disponível em várias cores. Quadro branco.

Pizarra tipo caballete a doble cara, fabricada en acero pintado al epoxi para mayor protección. Se suministra en una variedad de colores, y se puede colocar una pizarra blanca para rotuladores que se suministra aparte.

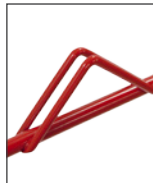
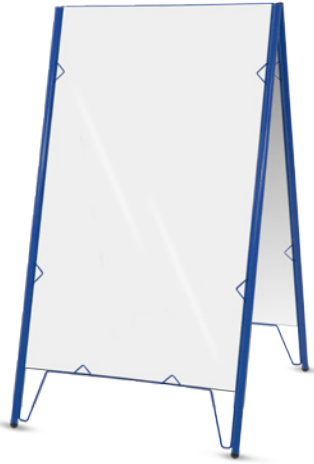

10.167

600x1000mm



10.168

Whiteboard - 590x995mm



Dover

Einfacher Kunststoffpräsentier für alle Arten der Präsentation. Ungefährer visueller Bereich ist 500x700mm. Geeignet zum Bedrucken und zum Bekleben. Leicht zu bewegen und zu lagern. Kann mit schwarzer Tafel zum Beschriften mit Kreide geliefert werden.

Poster stand made of plastic. Three different models. Approximate Dimensions: 500x700mm.

Chevalet en plastique avec trois configurations différentes. Facile à déplacer et à ranger. Dimensions approximatives: 500x700mm.

Cavalete em PVC branco para colocação de imagens. Disponível em 3 modelos diferentes.

Caballete fabricado en PVC. Tres modelos diferentes. Dimensión aproximada: 500x700mm.

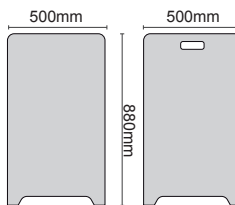
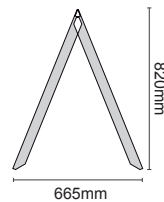

	QTY	N.W(kg)	G.W(kg)	C.B.M.	Size(mm)
Packing	1	1.5	2.1	0.025	520x55x885

13.129

480x815mm



13.130

480x815mm



13.131

Blackboard - 480x815mm



13.130

13.131

LIGHT BOX

3

Yucatan

Beleuchteter Aluminiumrahmen mit Klicksystem. Inklusive Schutzfolie.

LED light box. Using "click" profile system and silver anodized aluminium. AC power supply included. Protected by a thin anti-reflex cover.

Cadre lumineux à Leds pour fixation murale. Fabriqué en aluminium avec des profils click pour un changement facile de l'image.

Marco de uma face com leds e perfil "click" em alumínio anodizado. Inclui transformador. Material: alumínio e plástico.

Marco luminoso a pared con sistema de apertura "click". Fabricado en aluminio. Film protector.



13.207	A0			
13.208	A1			
13.209	A2			
13.210	A3			
13.211	A4			
13.295	500x700mm			
13.296	700x1000mm			

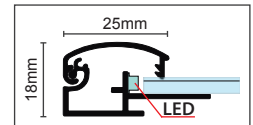

* Weitere Größen auf Anfrage / Other sizes available by request / Autres dimension sur demande / Outros tamanhos disponíveis sob consulta / Otros tamaños disponibles bajo pedido.

Artega

Beleuchteter Aluminiumrahmen mit Klicksystem.

LED light box. With clamp profile, silver anodised aluminium. AC power supply included. Material: Aluminium, plastic parts.

LED light box. Using "click" profile system and silver anodized aluminium. AC power supply included. Protected by a thin anti-reflex cover.

Marco de uma face com leds e perfil "click" em alumínio anodizado. Inclui transformador. Material: alumínio e plástico.

Marco luminoso fabricado en aluminio. Sistema de apertura "click".



13.202	A0			
13.203	A1			
13.204	A2			
13.205	A3			
13.206	A4			
13.293	500x700mm			
13.294	700x1000mm			

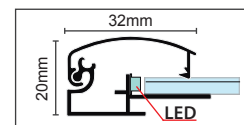

* Weitere Größen auf Anfrage / Other sizes available by request / Autres dimension sur demande / Outros tamanhos disponíveis sob consulta / Otros tamaños disponibles bajo pedido.

Campeche

Beleuchteter Aluminiumrahmen mit Klicksystem. Einfache und schnelle Öffnung für Grafikaustausch.

LED light box. Using "click" profile system and silver anodized aluminium. AC power supply included. Protected by a thin anti-reflex cover.

Cadre lumineux à Leds pour fixation murale. Fabriqué en aluminium avec des profils click pour un changement facile de l'image.

Marco de uma face com leds e perfil "click" em alumínio anodizado. Inclui transformador. Material: alumínio e plástico.

Marco luminoso a pared con sistema de apertura "click". Fácil y rápida apertura para el cambio de gráficas. Fabricado en aluminio.

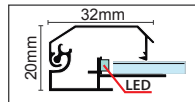

13.217	A0		
13.218	A1		
13.219	A2		
13.220	A3		
13.221	A4		
13.291	500x700mm		
13.292	700x1000mm		



* Weitere Größen auf Anfrage / Other sizes available by request / Autres dimension sur demande / Outros tamanhos disponíveis sob consulta / Otros tamaños disponibles bajo pedido.

Nogales

Doppelseitiger, beleuchteter Aluminiumrahmen mit Klicksystem. Weitere Größen auf Anfrage.

LED light box. Using "click" system and silver anodized aluminium. AC power supply included. Protected by a thin anti-reflex cover.

Cadre lumineux à Leds pour fixation au mur. Fabriqué en aluminium avec des profils click pour un changement d'image facile.

Marco de dupla face com leds e perfil "click" em alumínio anodizado. Inclui transformador. Material: alumínio e plástico.

Marco luminoso de doble cara fabricado en aluminio. Sistema de apertura "click".

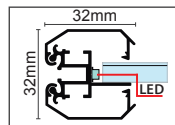

13.190	A0		
13.191	A1		
13.192	A2		
13.193	A3		
13.194	A4		
13.289	500x700mm		
13.290	700x1000mm		



* Weitere Größen auf Anfrage / Other sizes available by request / Autres dimension sur demande / Outros tamanhos disponíveis sob consulta / Otros tamaños disponibles bajo pedido.

LIGHT BOX

3

Sintra

Beleuchteter Bilderrahmen mit schmalen Aluminiumprofil, ein- oder doppelseitig. Hervorragende Lichtverteilung durch Kantenbeleuchtung, ohne Hot Spot.

LED light box single or double-sided. Using "click" profile system and silver anodized aluminium, also incorporates acrylic parts.

Cadre lumineux en aluminium, soutenu par un système de pattes avec roulettes qui permet son déplacement de façon facile.

Estrutura com marco de uma ou dupla face com leds e perfil "click" em alumínio anodizado. Material: alumínio e acrílico.

Marco luminoso LED con perfil de aluminio sistema de apertura "click". Posibilidad de 1 ó 2 caras.

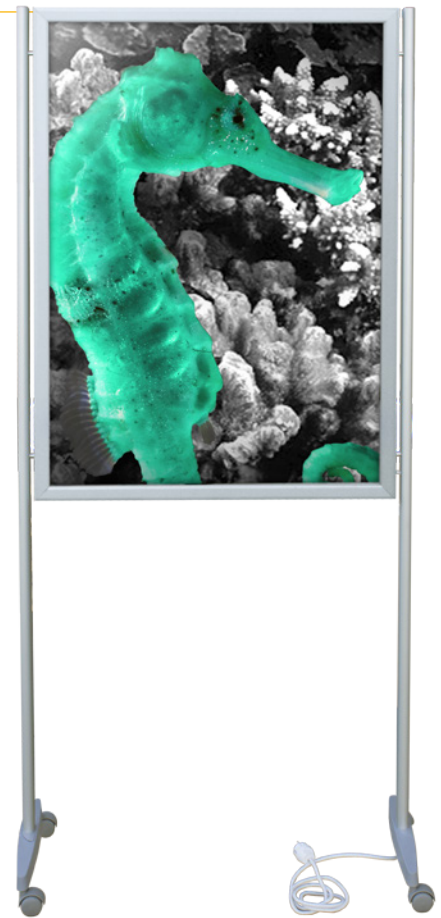
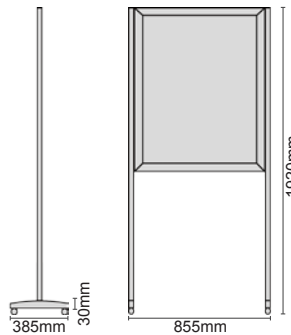

	QTY	N.W(kg)	G.W(kg)	C.B.M.	Size(mm)
Packing	1	17	20	0.155	940x85x1950
10.765		700x1000mm			
Packing	1	18.4	21.5	0.155	940x85x1950
10.767		700x1000mm			

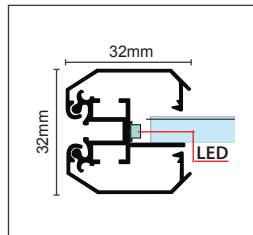

Totem Wall Light Box Genova

Beleuchtetes Säulendisplay für die Wand. Aluminiumprofil mit praktischem Klicksystem. Stahl Abdeckung.

Single sided lightbox it has a click/snap system for fast and easy exchange of graphic. Aluminium, plastic parts.

Totem courbé et lumineux pour mur. Profil d'aluminium, système d'ouverture "click" et couvercle en acier.

Totem curvo e luminoso de uma face para parede. Perfil de alumínio com abertura em "click" e tapanas de aço.

Tótem curvo luminoso para pared. Perfil de aluminio sistema de apertura "click" y tapanas de acero.

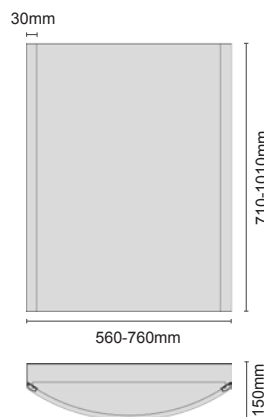

10.117	500x700mm		
10.348	700x1000mm		



LIGHT BOX

Obidos



DE Doppelseitiges, beleuchtetes Säulendisplay mit Stahlbasis. Grau lackiert.

UK Curved lightbox. Profile double-sided for graphic assembly with durable aluminium frame. Painted in gray.

FR Totem lumineux, courbé double face. Il est composé d'une base en acier, d'un profil en aluminium et de parties en plastique.

PT Totem curvo e luminoso de dupla face com estrutura metálica e base em aço.

ES Tótem curvo luminoso metálico para montar gráfica. Doble cara, base en acero. Pintado en color gris.

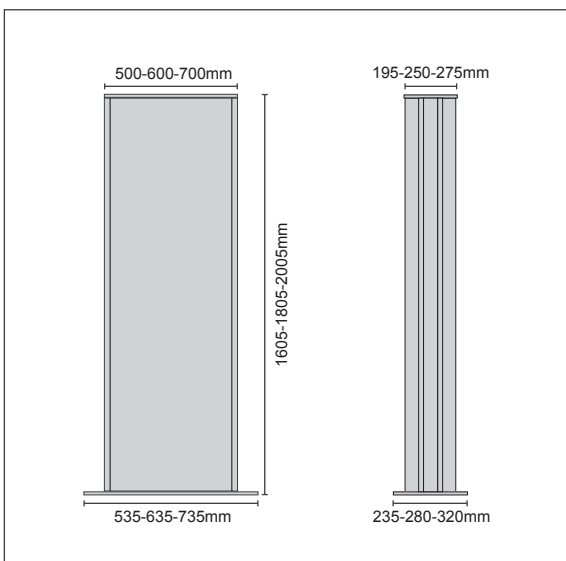

10.221	500x1600mm		
10.222	600x1800mm		
10.223	700x2000mm		

LIGHT BOX

3

Nantes

Doppelseitige Lightbox mit Klicksystem für schnellen und einfachen Austausch der Grafik.

Single sided lightbox it has a "click" system for fast and easy exchange of graphic. Aluminium, plastic parts.

Totem lumineux, courbé double face. Profil en aluminium d'ouverture click.

Totem curvo de dupla face com estrutura metálica e base em aço. Fornecido com ou sem iluminação.

Tótem curvo luminoso. Perfil de aluminio sistema de apertura "click" y tapas de acero.

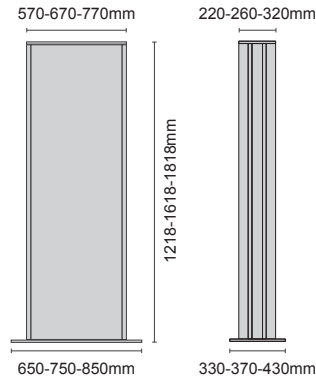

10.602			
10.402	500x1200mm		
10.436			
10.464	500x1600mm		
10.460			
10.465	600x1800mm		
10.521			
10.556	700x1800mm		

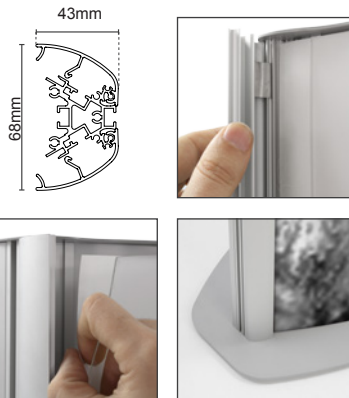

Cascais

Doppelseitiges Bodendisplay, grau lackiert. Sockelplatte aus Stahl. Kann beleuchtet werden.

Straight, double-sided profile with durable aluminium frame. Available with light. Material: Aluminium, steel, plastic parts.

Totem double face droit avec base métallique. Disponible avec ou sans éclairage.

Totem recto de dupla face com estrutura metálica e base em aço. Fornecido com ou sem iluminação.

Tótem recto metálico para montar gráfica. Doble cara, base en acero. Pintado en color gris. Disponible con y sin luz.

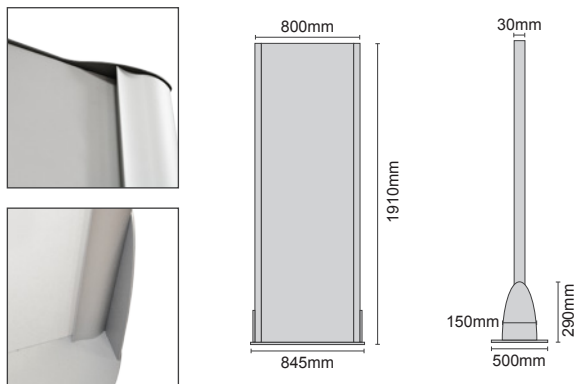

10.354	700x1900mm		
10.356	700x1900mm		

BROCHURE STAND

Sagres

Aluminium-Prospektständer. DIN A4 Prospekthalter aus Kunststoff oder Metall.

Brochure stand for A4 brochures made with a heavy foot. The shelf is made of strong Polycarbonate or Steel.

Support Porte brochure avec plateau A4 en aluminium ou plastique.

Suporte em alumínio com bandeja de acrílico ou metálica para folhetos A4.

Portafolletos realizado en aluminio con bandeja para folletos en tamaño A4, realizado en metacrilato o metálico.

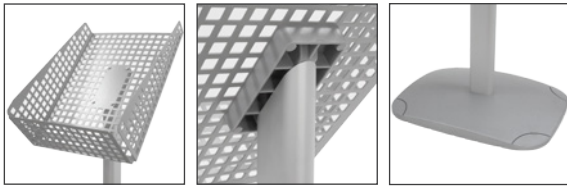

	QTY	N.W(kg)	G.W(kg)	C.B.M.	Size(mm)
Packing	1	2.9	3.6	0.032	295x120x910

10.473 Acrylic

	QTY	N.W(kg)	G.W(kg)	C.B.M.	Size(mm)
Packing	1	2.4	3.45	0.032	295x120x910

10.474 Steel

Bari

Präsentationspult, Stahlblech DIN A4 Ablagefläche, grau lackiert.

Catalogue display for A4 portrait brochures. Colour: Grey. Material: Steel.

Support porte brochures en acier. Idéal pour brochures format A4.

Estrutura em chapa de aço pintada de cinzento, ideal para catálogos formato A4. Material: aço.

Portacatálogos realizado en chapa de acero y pintado en color gris. Ideal para la colocación de catálogos tamaño A4.

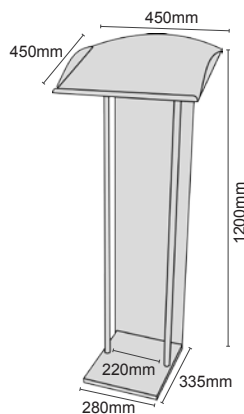



	QTY	N.W(kg)	G.W(kg)	C.B.M.	Size(mm)
Packing	1	8.6	11	0.312	500x500x1250

10.219





Vegas

 Faltbarer Prospektständer aus verchromtem Stahl und Kunststoff. DIN A4 Format. Der perfekte Begleiter für Messeauftritte oder Produktpräsentationen. Höhe 1550mm.

 Foldable brochure stand for A4 catalogs. Simple folding, becomes an important ally for fairs and shows. Made of plastic and chrome steel. Height: 1550mm.

 Présentoir de catalogues pliable avec 4 divisions de dimension A4. Fabriqué en acier et plastique. Hauteur : 1550 mm.

 Porta-catálogos desdobrável. Possui 4 bolsa A4 em acrílico. Ideal para feiras e demonstrações em pontos de venda. Material: aço e acrílico. Altura: 1550mm.

 Expositor soporte para catálogos tamaño A4. De plegado ultrafácil, se convierte en un importante aliado para ferias y demostraciones en punto de venta. Fabricado en plástico y acero cromado. Altura: 1550mm.



10.048

Height: 1550mm





Sahagun

 Faltbarer Prospektständer aus matt - grauem Aluminium und transparentem Kunststoff. Besteht aus 5 Ablagefächern. Gestell ist epoxybeschichtet.

 Foldable brochure stand. Lightweight design in aluminium. Quick and easy to unfold. Includes alu. suitcase. Available in acrylic or wood.

 Porte-brochure portable fabriqué en acrylique transparent et aluminium gris mat. Comprend 5 compartiments pour brochures, poignée et base peinte en époxy.

 Porta-catálogos portátil fabricado em acrílico transparente e alumínio cinzento baço. Possui 5 compartimentos para folhetos, Asa e base em metal pintada com epóxi.

 Portafolletos portátil fabricado en metacrilato transparente y aluminio gris en acabado mate. Consta de 5 compartimentos para folletos, asa y base en chapa pintada epoxi.



10.047

Height: 1500mm



Soubran

 Faltbarer Prospektständer aus Stahl mit 5 Ablagefächer DIN A4. Mit Abschlussblende für Beschriftung. Höhe 1420mm

 Folding brochure stand, steel structure, five A4 shelves. The bottom can be used to place a graphic. Height: 1420mm.

 Porte brochure pliable, fabriqué en acier. Avec 5 compartiments A4 et un espace pour un visuel. Hauteur: 1420mm.

 Porta-catálogos desdobrável fabricado em aço. Possui cinco divisória A4. Altura: 1420mm.

 Portafolletos plegable fabricado en acero. Cuenta con 5 bolsillos A4 y espacio para rotular gráfica. Altura: 1420mm.



10.416

Height: 1420mm

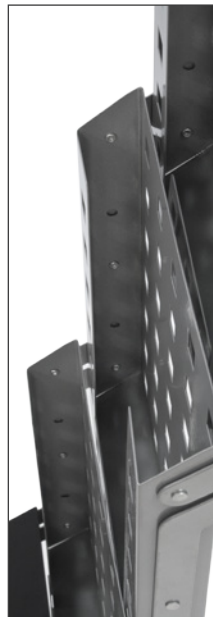



Mentrida

 Faltbarer Prospektständer. Hergestellt aus Draht und Stahl. 5 x DIN A4-Fächer.

 Foldable brochure stand. Made of wire and steel. 5 x A4 portrait pockets.

 Présentoir de catalogues avec 4 divisions de dimension A4.

 Porta-catálogos desdobrável, fabricado em aço. Possui 5 divisórias A4. Possibilidade de colocar uma impressão na parte superior e inferior.

 Portafolletos plegable fabricado en tubo y varilla color negro. Cuenta con 5 bolsillos y espacio para rotular.

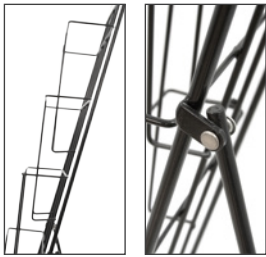



10.720

Height: 1460mm

Bañeza

 Prospektständer mit Aluminiumgestell, schwarz lackiert, 7 Broschürenfächer, mit Abschlussblenden/ Beschriftungsfläche, z.B. für firmeneigenes Logo.

 Brochure stand. Made of wire and steel. It has seven portrait pockets, size A4. Material: Steel.

 Présentoir de catalogues avec 7 divisions de dimension A4.

 Porta-catálogos em aço para catálogos A4, com 7 divisões. Parte superior e inferior disponível para colocar uma impressão.

 Portafolletos de pie, fabricado en tubo de acero pintado en negro. Cuenta con siete bolsillos y espacio para rotular gráfica.

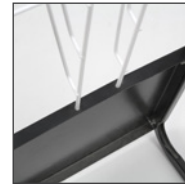
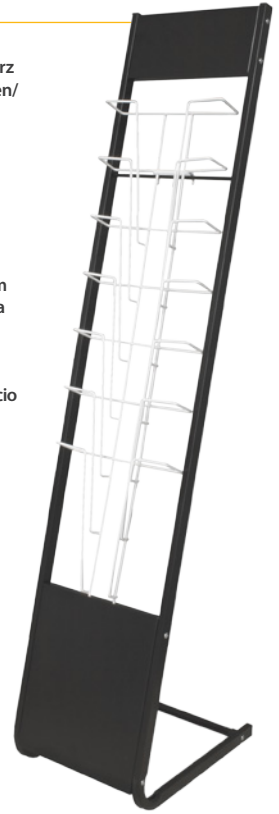



10.044

280x1360mm

Sil

 Leichter Prospektständer aus Nylon mit Aluminiumgestell, DIN A4. Schneller und einfacher Aufbau, ideal zum Mitnehmen. Verfügbar mit 1 oder 2 Fächerreihen. Höhe 1360mm.

 Brochure stand available for A4 catalogs. Fast and lightweight, ideal for travelling mounting demonstrations. Made of nylon and aluminum. Available in single or double version. Height: 1360mm.

 Présentoir de catalogues A4, léger, de montage facile, idéal pour les démonstrations itinérantes. Fabriqué en nylon et aluminium. Disponible en version simple ou double. Hauteur: 1360mm.

 Expositor para catálogos A4, em formato simples ou duplo. Fácil de montar e de transportar. Mala incluída. Altura: 1360mm. Material: alumínio, aço e nylon.

 Expositor soporte para catálogos tamaño A4. Montaje rápido y de poco peso, es ideal para demostraciones itinerantes. Fabricado en nylon y aluminio. Disponible en versión doble o sencilla. Altura: 1360mm.

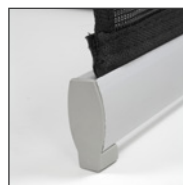

10.051

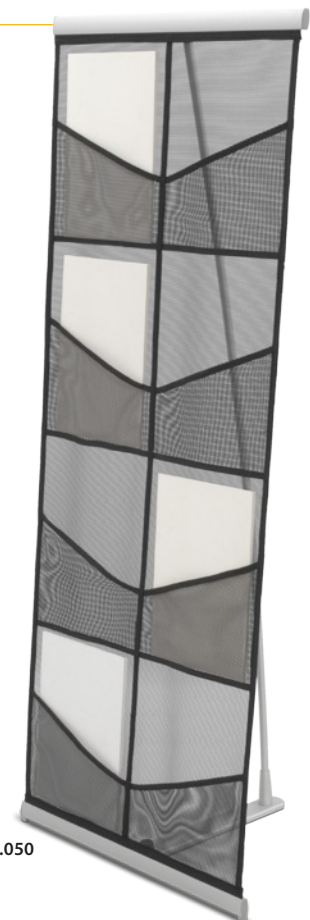

10.050

10.050

Double



10.051

Single



Legnica

 Faltbarer Prospektständer aus Aluminium, grau lackiert und transparentem Kunststoff, 8 Fächer in DIN A4 Format.

 Double Holder portable and foldable, made of transparent acrylic and gray aluminum. It consists of 8 compartments for DIN A4 brochures.

 Présentoir de catalogue double et pliable avec 8 divisions de dimension DIN A4. Fabriqué en acier et plastique.

 Porta-catálogos desdobrável em aço e acrílico. Dispõe de 8 divisórias DIN A4.

 Portafolletos doble portátil y plegable, fabricado en metacrilato transparente y aluminio gris. Consta de 8 compartimentos para folletos DIN A4.



10.114

1560mm



Nelas

 Drehbarer Drahtprospekthalter auf Rollen, DIN A4.

 Wire brochure holder with wheels. Shape: DIN A4. Material: Steel, plastic.

 Porte catalogue de format DIN A4 avec roulettes.

 Porta-catálogo giratório com rodas. Tamanho DIN A4. Fabricado em aço e plástico.

 Portacatálogos giratorio con ruedas, realizado en varilla. Tamaño DIN A4.





13.101

1400mm





Cañamo

 Prospektständer aus Aluminium mit 4 Ablageflächen aus Kunststoff. Kapazität für 2x A4 pro Ablagefläche. Größe: 620x390x1770mm.

 Single side brochure stand. Designed for 8 x A4 brochures. The feet are made of aluminium and disposes of acrylic supports. Size: 620x390x1770mm.

 Porte-brochure fabriqué en aluminium, composé de 4 supports en acrylique. Prévu pour exposer 2x A4 par support. Dimensions: 620x390x1770mm.

 Porta-catálogo fabricado em alumínio. Cada uma das suas 4 prateleiras está concebida para dois catálogos A4. Dimensões: 620x390x1770 mm.

 Portafolletos realizado em alumínio. Dispone de 4 soportes de metacrilato para la exposición de folletos o catálogos. Válido para colocar 2x A4 por soporte. Tamaño: 620x390x1770mm.

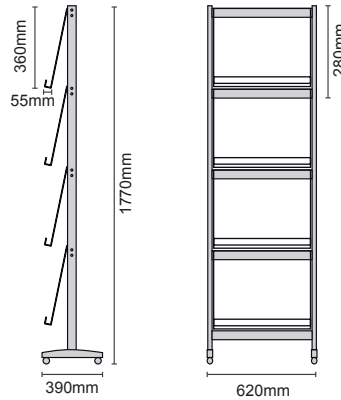



	QTY	N.W(kg)	G.W(kg)	C.B.M.	Size(mm)	
Packing	1	7.3	9	0.048	410x165x720	 x2
		6.45	8.05	0.077	630x70x1750	

10.468

Abad

 Prospektständer mit 4 Ablageflächen aus Kunststoff. Rahmen mit Klicksystem für Grafik. Kapazität für 2x A4 pro Ablagefläche. Grafikgröße: 460x260mm.

 Single side brochure stand. Designed for 8 x A4 brochures. The feet are made of aluminium and disposes of acrylic supports. Aluminium frame is using the "click" system. Size: 460x260mm.

 Porte-brochure fabriqué en aluminium, avec 4 supports en acrylique. Composé d'un cadre « click » permettant la mise en place d'un visuel dans la partie supérieure. Permet d'exposer 2 x A4 sur chaque support. Format du visuel: 460 x 260mm.

 Porta-catálogo fabricado em alumínio. Possui um marco "click" na parte superior para uma impressão de 460x260mm e 4 bandejas em acrílico que permitem a colocação de 2 catálogos A4 em cada uma.

 Portafolletos realizado em alumínio con 4 soportes de metacrilato. Dispone de un marco "click" para la colocación de gráfica en su parte superior. Válido para colocar 2x A4 por soporte. Medida de gráfica: 460x260mm.

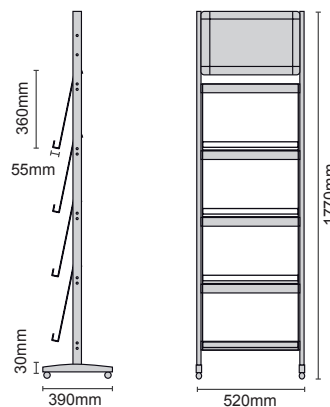

	QTY	N.W(kg)	G.W(kg)	C.B.M.	Size(mm)	
Packing	1	7.3	9	0.048	410x165x720	 x2
		6.45	8.05	0.077	630x70x1750	

10.467

460x260mm

* Druck / Printing / Impression / Impressão / Impresión.

Sotillo

Prospektständer aus Aluminium mit 4 Ablageflächen aus Kunststoff. Rahmen mit Klicksystem für Grafik. Kapazität für 3x DIN A4 pro Ablagefläche. Grafikgröße: 675x195mm.

Single side brochure stand with "click" frame. Designed for 12 x A4 brochures. The feet are made of aluminium, the supports of acrylic. Visual size: 675 x 195mm.

Porte-brochure fabriqué en aluminium, avec 4 supports en acrylique. Composé d'un cadre « click » permettant la mise en place d'un visuel dans la partie supérieure. Permet d'exposer 3 x A4 sur chaque support. Format du visuel: 675 x 195mm.

Porta-catálogo fabricado em alumínio. Possui um marco "click" na parte superior para uma impressão de 675x195 mm e 4 bandejas em acrílico que permitem a colocação de 3 catálogos A4 em cada uma.

Portafolletos realizado en aluminio. Dispone de 4 soportes de metacrilato para la exposición de folletos o catálogos y de un marco "click" en su parte superior para la colocación de gráficas. Válido para colocar 3x A4 por soporte. La medida de la gráfica del marco superior es 675x195mm.

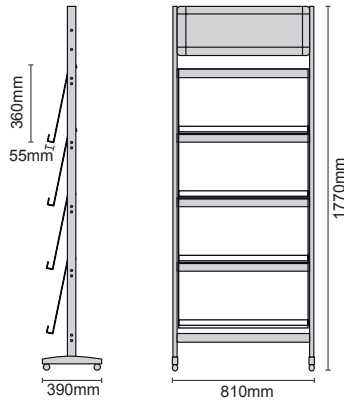

	QTY	N.W(kg)	G.W(kg)	C.B.M.	Size(mm)
Packing	1	9	10.5	0.062	410x165x920
		7.35	9.35	0.101	830x70x1750

x2

10.469 675x195mm

* Druck / Printing / Impression / Impressão / Impresión.

Olmedilla

Präsentationssystem aus Aluminium mit Prospekthalter aus Kunststoff. Kapazität für 3x A4.

Double-sided brochure stand with boxes and aluminium foot. It has 1 acrylic support for displaying brochures or catalogs. Suitable for placing 3 x A4 brochures.

Porte-brochure avec demi-totem, fabriqué en aluminium. Composé d'un support en acrylique. Permet d'exposer 3 x A4 sur chaque support.

Combinado de suporte para catálogos com totem na parte superior. Fabricado em alumínio e com 1 bandeja em acrílico que permite a colocação de 3 catálogos A4.

Portafolletos con medio tótem, realizado en aluminio. Dispone de 1 soporte de metacrilato para la exposición de folletos o catálogos. Válido para colocar 3x A4 por soporte.

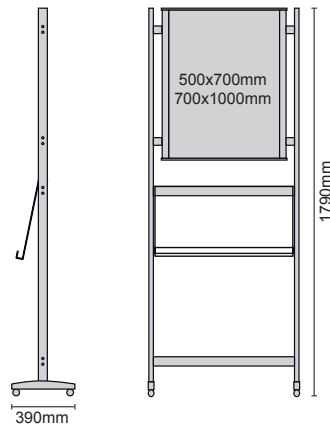

	QTY	N.W(kg)	G.W(kg)	C.B.M.	Size(mm)
Packing	1	11.5	13.4	0.243	650x205x1825

10.472 500x700mm

	QTY	N.W(kg)	G.W(kg)	C.B.M.	Size(mm)
Packing	1	17	18.5	0.372	850x240x1825

10.273 700x1000mm



Verona

Fahrbarer Prospektständer aus Aluminium und transparentem Kunststoff. Einfache Montage. Füße mit Rollen inklusive.
 Ref: 10.217: 4 transparente Ablageflächen, Breite 275mm. Kapazität für 4x A4.
 Ref: 10.218: 4 transparente Ablageflächen, Breite 750mm. Kapazität für 12x A4.

Made of aluminum and methacrylate. Includes feet with casters. Easy to assemble.
 Ref: 10.217: Has 4 shelves of 275mm wide done in methacrylate. Capacity 4x A4.
 Ref: 10.218: Has 4 shelves 750mm wide done in methacrylate. Capacity 12x A4.

Porte brochures en aluminium et acrylique. Inclus pieds avec roulettes. Montage facile.
 Réf: 10.217: Composé de 4 étagères en acrylique de 275mm de large. Capacité 4x A4.
 Réf: 10.218: Composé de 4 étagères en acrylique de 750mm de large. Capacité 12x A4.

Porta-catálogos em alumínio e acrílico. Fácil de montar e com rodas. Bandejas:
 Ref: 10.217: 340x1665x380. Capacidade de: 4XA4.
 Ref: 10.218: 815x1665x380. Capacidade de: 12XA4.

Realizado en aluminio y metacrilato. Incluye patas con ruedas giratorias. Fácil montaje.
 Ref: 10.217: 4 baldas de 275mm de ancho. Capacidad 4x A4.
 Ref: 10.218: 4 baldas de 750mm de ancho. Capacidad 12x A4.



	QTY	N.W(kg)	G.W(kg)	C.B.M.	Size(mm)
Packing	1	3	3.95	0.030	420x170x430
		4.45	5	0.018	145x80x1620



10.217 **255x147mm**

* Druck / Printing / Impression / Impressão / Impresión.

	QTY	N.W(kg)	G.W(kg)	C.B.M.	Size(mm)
Packing	1	6.8	7.85	0.071	430x185x900
		4.45	5	0.018	145x80x1620



10.218 **730x147mm**

* Druck / Printing / Impression / Impressão / Impresión.

Athy

Wand-Prospekthalter aus Aluminium. 8xDIN A4.

Wall-Mounted leaflet dispenser. Used for 8x A4. Aluminium, acrylic.

Porte documents en aluminium à fixer au mur. Capacité : 8x A4.

Porta-catálogos de parede, fabricado em alumínio. Capacidade 8x A4.

Portafolletos a pared fabricado en aluminio. 8 x A4.

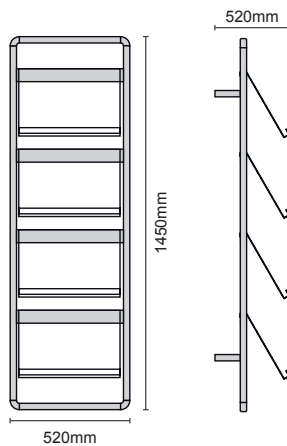
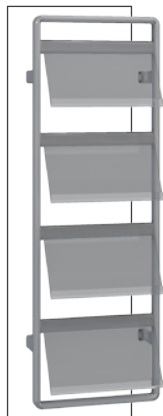

10.988



Cañada

Präsentationssystem aus Aluminium mit 4 Ablageflächen aus Kunststoff, einer Leuchtsäule und einem Display. Druck nicht inklusive. Kapazität für 1x DIN A4 pro Ablagefläche. Größe: 820x1700x280mm. Grafikgröße für Säule: 324x1685mm. Grafikgröße Display: 430x1100mm.

Double-sided brochure stand done in Aluminium. It has 4 mounting acrylic supports for exhibiting brochures or catalogs, a totem pole with light and a stand for a graph. Printing not included. Designed for 1xA4 brochures. Dimension 820x1700x280 mm. Visual format totem: 324x1685mm. Lateral visual size: 430x1100mm.

Porte-brochure fabriqué en aluminium. Composé de 4 supports en acrylique, d'un totem lumineux et d'un support pour visuel. Permet d'exposer 1xA4 sur chaque support. Visuel non inclus. Dimension 820x1700x280mm. Format du visuel du totem: 324x1685mm. Format du visuel latéral: 430x1100mm.

Totem com porta-folhetos fabricado em alumínio. Inclui 4 suportes em acrílico para catálogos ou folhetos, um totem com luz e um suporte para impressão. Capacidade por suporte: 1xA4. Tamanho: 820x1700x280mm. Medidas de impressão totem: 324x1685mm. Medida de impressão lateral: 430x1100mm.

Portafolletos - Tótem, realizado em alumínio. Dispõe de 4 soportes de metacrilato para exposição de folhetos ou catálogos, um tótem com luz y un soporte para una gráfica. Gráfica no incluida. Válido para colocar 1xA4 por soporte. Tamaño: 820x1700x280mm. Medida gráfica Tótem: 324x1685mm. Medida gráfica lateral: 430x1100mm.

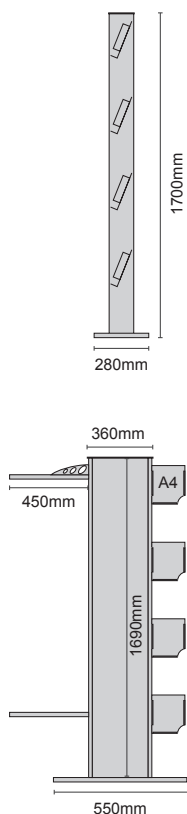

	QTY	N.W(kg)	G.W(kg)	C.B.M.	Size(mm)
Packing	1	18.5	19.7	0.375	625x345x1740

10.470

Totem 324x1685mm
Poster 430x1100mm



* Druck / Printing / Impression / Impressão / Impresión.

Hito

Präsentationssystem aus Aluminium mit 3 Ablageflächen aus Kunststoff und einem Display. Kapazität für 1x DIN A4 pro Ablagefläche. Größe: 880x1815x450mm. Grafikgröße Display: 600x1500mm.

Brochure holder made of aluminum. It has 3 acrylic supports for exhibiting catalogs and brochures and support for a graph. Suitable for placing 1xA4 per support. Size: 880x1815x450mm. Lateral extent graph: 600x1500mm.

Porte-brochure sur pied fabriqué en aluminium. Composé de 3 supports en acrylique et d'un support pour visuel. Permet d'exposer 1xA4 sur chaque support. Visuel non inclus. Dimension: 880x1815x450 mm. Format du visuel latéral: 600x1500 mm.

Suporte para impressão com porta-folhetos fabricado em alumínio. Inclui 3 suportes em acrílico para catálogos ou folhetos e um suporte para impressão. Capacidade: 3xA4. Tamanho: 880x1815x450mm. Medida de impressão: 600x1500mm.

Portafolletos realizado em alumínio. Dispõe de 3 soportes de metacrilato para la exposición de folletos o catálogos y un soporte para una gráfica. Válido para colocar 1xA4 por soporte. Tamaño: 880x1815x450mm. Medida gráfica lateral: 600x1500mm.

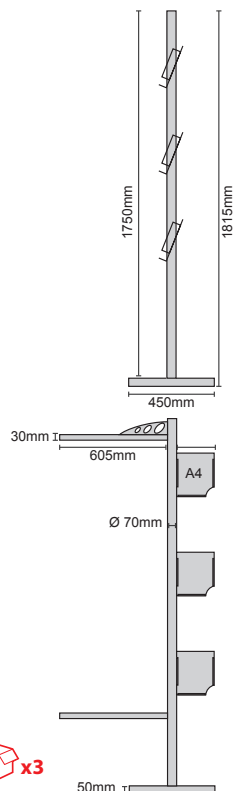

	QTY	N.W(kg)	G.W(kg)	C.B.M.	Size(mm)
Packing	1	2.8	3.6	0.0123	80x80x1920
		9.55	10	0.0156	465x72x465
		1.6	1.9	0.019	390x75x650

10.471

600x1500mm



* Druck / Printing / Impression / Impressão / Impresión.





OUTDOOR

Tents	202
Inflatable	207
Outdoor Ashtrays	210

Steel Tent 2x2

 Faltpavillon mit weißem Stahlgestell, schnelle und einfache Montage. Ideal für Events im Outdoor Bereich. Abmaße: 2000x2000mm. Verfügbar in 3 Farben: Weiß, Blau und Rot.

 Promotional tent made of steel and painted in white. Size: 2000x2000mm. Ideal for outdoor events. Easy to assemble. Available in white, blue and red.

 Tente pour événements, fabriquée en acier peint en blanc. Dimensions: 2000x2000mm. Idéale pour les événements extérieurs. Montage facile. Disponible en trois couleurs, blanc, bleu ou rouge.

 Tenda com estrutura de aço disponível com toldos na cor branca, azul ou vermelha. Materiais: Aço, plástico e tecido.

 Carpa para eventos realizada en acero pintado en blanco. Tamaño: 2000x2000mm. Ideal para eventos de exterior. Fácil montaje. Disponible en tres colores, blanco, azul y rojo.

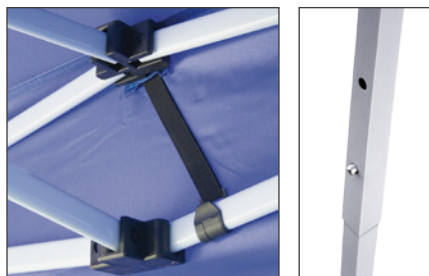

10.181

10.182

10.183

2000x2000mm



Steel Tent 2x3

 Faltpavillon mit weißem Stahlgestell, schnelle und einfache Montage. Ideal für Events im Outdoor Bereich. Abmaße: 2000x3000mm. Verfügbar in 3 Farben: Weiß, Blau und Rot.

 Promotional tent made of steel and painted in white. Size: 2000x3000mm. Ideal for outdoor events. Easy to assemble. Available in white, blue and red.

 Tente pour événements fabriquée en acier peint en blanc. Dimensions: 2000x3000mm. Idéale pour les événements extérieurs. Montage facile. Disponible en trois couleurs, blanc, bleu ou rouge.

 Tenda com estrutura de aço disponível com toldos na cor branca, azul ou vermelha. Materiais: Aço, plástico e tecido.

 Carpa para eventos realizada en acero pintado en blanco. Tamaño: 2000x3000mm. Ideal para eventos de exterior. Fácil montaje. Disponible en tres colores, blanco, azul y rojo.



10.184

10.185

10.186

2000x3000mm



Steel Tent 3x3

 Faltpavillon mit weißem Stahlgestell, schnelle und einfache Montage. Ideal für Events im Outdoor Bereich. Abmaße: 3000x3000mm. Verfügbar in Blau und Rot.

 Economic tent made of steel painted in white. Size 3000x3000mm. Ideal for outdoor events. Easy to assemble, available in red and blue.

 Tente pour événements, fabriquée en aluminium peint en blanc. Dimensions 3000x3000mm. Idéale pour événements extérieurs. Montage facile. Disponible en deux couleurs, rouge ou bleu.

 Tenda com estrutura de aço disponível com toldos na cor branca, azul ou vermelha.

 Carpa para eventos realizada en acero pintado en blanco. Tamaño 3000x3000mm. Ideal para eventos de exterior. Fácil montaje. Disponible en dos colores, rojo y azul.





10.818 

10.817  3000x3000mm



Steel Tent 3x3

 Faltpavillon mit weißem Stahlgestell, schnelle und einfache Montage. Ideal für Events im Outdoor Bereich. Abmaße: 3000x3000mm. Verfügbar in 3 Farben: Weiß, Blau und Rot.

 Tent made of steel and painted in white. Size: 3000x3000mm. Ideal for outdoor events. Easy to assemble. Available in white, blue and red.

 Tente pour événements fabriquée en acier peint en blanc. Dimensions: 3000x3000mm. Idéale pour événements extérieurs. Montage facile. Disponible en trois couleurs, blanc, bleu ou rouge.

 Tenda com estrutura de aço disponível com toldos na cor branca, azul ou vermelha. Materiais: Aço, plástico e tecido.

 Carpa para eventos realizada en acero pintado en blanco. Tamaño: 3000x3000mm. Ideal para eventos de exterior. Fácil montaje. Disponible en tres colores, blanco, azul y rojo.



3x3 m



10.187

10.188

10.189

3000x3000mm





Aluminium Tent

 Faltpavillon aus Aluminiumgestell und Polyester, schnelle und einfache Montage. Inklusive 4 Seitenwände mit einer Höhe von 2150mm, eine Wand mittig geteilt als Eingang. Ideal für Events im Outdoor Bereich. Verfügbar in 2 Größen.

 Event tent made in aluminum and polyester. Includes four sides of 2150mm high each, one configured as an entry. Ideal for outdoor events and easy to assemble. Available in two sizes.

 Tente pour événements, fabriquée en aluminium et polyester. Inclus, quatre cotés de 2150mm de hauteur, l'un d'eux servant comme porte d'accès. Idéale pour événements extérieurs, montage facile. Disponible en deux dimensions.

 Tenda de alumínio com laterais. Materiais: Alumínio, plástico e tecido.

 Carpa para eventos realizada en aluminio y poliéster. Incluye cuatro laterales de 2150mm de alto, uno de ellos configurado como puerta de acceso. Ideal para eventos de exterior y de fácil montaje. Disponible en dos tamaños.

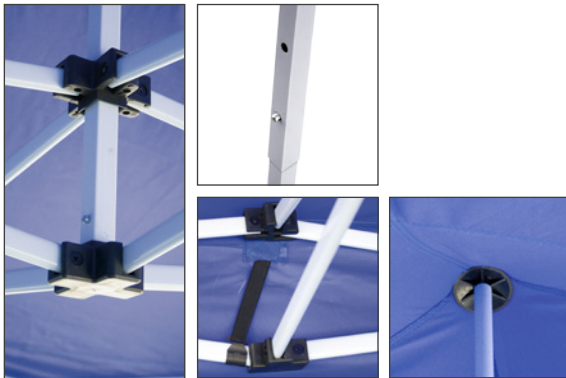

10.433

3000x3000mm

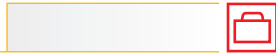

10.434

3000x4500mm

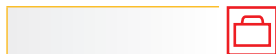

Steel Tent 3x4,5



Faltpavillon mit weißem Stahlgestell, schnelle und einfache Montage. Ideal für Events im Outdoor Bereich. Abmaße: 3000x4500mm. Verfügbar in 3 Farben: Weiß, Blau und Rot.

Event tent made of steel painted in white. Size: 3000x4500mm. Ideal for outdoor events. Easy to assemble. Available in white, blue and red.

Tente pour événements, fabriquée en acier peint en blanc. Dimensions: 3000x4500mm. Idéale pour les événements extérieurs. Montage facile. Disponible en trois couleurs, blanc, bleu ou rouge.

Tenda com estrutura de aço disponível com toldos na cor branca, azul ou vermelha. Materiais: Aço, plástico e tecido.

Carpa para eventos realizada en acero pintado en blanco. Tamaño: 3000x4500mm. Ideal para eventos de exterior. Fácil montaje. Disponible en tres colores, blanco, azul y rojo.



10.190

10.220

10.250

3000x4500mm



Steel Tent 3x6



Faltpavillon mit weißem Stahlgestell, schnelle und einfache Montage. Ideal für Events im Outdoor Bereich. Abmaße: 3000x6000mm. Verfügbar in 3 Farben: Weiß, Blau und Rot.

Event tent made of steel painted in white. Size: 3000x6000mm. Ideal for outdoor events. Easy to assemble. Available in white, blue and red.

Tente pour événements, fabriquée en acier peint en blanc. Dimensions: 3000x6000mm. Idéale pour événements extérieurs. Montage facile. Disponible en trois couleurs, blanc, bleu ou rouge.

Tenda com estrutura de aço disponível com toldos na cor branca, azul ou vermelha. Materiais: Aço, plástico e tecido.

Carpa para eventos realizada en acero pintado en blanco. Tamaño: 3000x6000mm. Ideal para eventos de exterior. Fácil montaje. Disponible en tres colores, blanco, azul y rojo.



10.251

10.252

10.253

3000x6000mm



Inflatable Arch

DE Aufblasbarer Torbogen für Sport-Events, überall und immer einsetzbar. Einfacher und schneller Aufbau. Bodenverankerung inklusive.

UK Inflatable arch; with electrical motor (pumps air continuously) great for any sport event, can be set-up on any ground, fasten strings and pins included, fast and easy to set-up.

FR Arche gonflable, idéal pour la réalisation d'événements sportifs sur le sol, le sable, l'herbe, la neige, etc. Cordes et chevilles pour la fixation incluses. Moteur à air continu inclus. Facile et rapide à monter.

PT Arco insuflável ideal para a realização de eventos desportivos em solo, areia, erva, neve, etc. Inclui cordas e cravelhas para a sua fixação e motor de ar contínuo. De fácil e rápida montagem.

ES Arco hinchable ideal para la realización de eventos deportivos sobre suelo, arena, hierba, nieve, etc. Incluye cuerdas y clavijas para su fijación. Motor de aire continuo incluido. Fácil y rápido montaje.



15.166

15.167

15.168



15.166

15.167

15.168 6000x4000mm



Air Dancer

DE Luftfigur für effektvolle Auftritte, schnelle und einfache Montage. Zusätzliche Aufmerksamkeit durch permanente Bewegung mittels Gebläse. Klettverband und zusätzlicher Stoff zum Personalisieren inklusive.

UK Air dancer with electrical fan motor (pumps air continuously) located at the bottom. The flowing air makes it dance. Big visual impact! It also includes Velcro and extra cloth for any adjustments and set-up of the graphic.

FR Structure gonflable, idéale pour capter l'attention du public, grâce à son constant mouvement. Grand impact visuel. Dispose d'un moteur à air continu à l'intérieur de la structure. Montage facile. Inclus velcro et tissus supplémentaires pour personnaliser l' Air Dancer.

PT Estrutura insuflável ideal para captar a atenção do público, graças ao seu constante movimento. Grande impacto visual. Dispõe de um motor de ar contínuo no interior do insuflável. Fácil montagem. Inclui velcro e tela adicional, como opção na hora de personalizar o Air dancer.

ES Estructura hinchable ideal para captar la atención del público, gracias a su constante movimiento. Gran impacto visual. Dispone de un motor de aire continuo en el interior del hinchable. Fácil montaje. Incluye velcro y tela adicional, como opción a la hora de personalizar el Air Dancer.



15.152

15.154 Ø 450x6000mm

Light Tube 2300mm

DE Beleuchtete Luftsäule, in wenigen Handgriffen aufgebaut, immer und überall einsetzbarer Werbeträger. Individuelle Gestaltung durch einfaches Austauschen der Grafik mittels Klettband.

UK Light tube with electrical fan motor (pumps air continuously) located inside of the tube. Used for any publicity display. Supplied with Velcro for fast and easy exchange of graphic.

FR Totem gonflable avec lumière à l'intérieur, de forme cylindrique, conçu pour être placé dans différents espaces et pour divers usages publicitaires. Dispose d'un moteur d'air continu à l'intérieur de la structure. Fourni avec velcro pour changer le visuel. Montage facile.

PT Tótem cilíndrico insuflável com luz no interior. Está preparado para colocar em diferentes espaços e usos publicitários. Dispõe de um motor de ar contínuo no interior do insuflável. Inclui velcro e tela adicional para alterar as imagens gráficas. Fácil de montar.

ES Tótem Hinchable con luz en su interior, de forma cilíndrica, preparado para colocar en diferentes espacios y distintos usos publicitarios. Dispone de un motor de aire continuo en el interior del hinchable. Se suministra con velcro para intercambiar las imágenes gráficas. Fácil montaje.



With light

2.3 m



15.155

15.156 Ø 400x2300mm



Inflatable Tent

DE Aufblasbarer Pavillon mit abnehmbaren Seitenteilen mittels Reißverschlüssen, mit wenigen Handgriffen aufgebaut. Ideal für Events im Outdoor Bereich mit ausreichendem Platz. Gebläse und Bodenverankerung inklusive.

UK Inflatable Tent with removable sides through zippers. Includes a continuous air motor that is positioned outside of it. Ideal for mounting large events and advertising publicity events. Supplied with strings and pins for the floor. Easy to assemble.

FR Tente gonflable avec cotés démontables à l'aide de fermetures. Inclus un moteur d'air continu qui se situe à l'extérieur de la structure. Idéale pour le montage d'événements et grand espaces publicitaires pouvant être personnalisés. Cordes et chevilles pour fixer au sol incluses. Montage facile.

PT Tenda insuflável com laterais desmontáveis mediante fecho zíper. Inclui um motor de ar contínuo no exterior do insuflável. Ideal para a realização de eventos. Dispõe de um grande espaço publicitário personalizável. Inclui cordas e cravelhas para fixar ao solo. Fácil de montar.

ES Carpa Hinchable con laterales desmontables mediante cremalleras. Incluye un motor de aire continuo que se sitúa en el exterior del hinchable. Ideal para el montaje de eventos y gran espacio publicitario para ser personalizada. Incluye cuerdas y clavijas para fijar al suelo. Fácil montaje.



4.25x4.25x2.9m





15.158

15.159 4250x4250x2900mm

Inflatable Auditorium Tent

 Aufblasbarer Pavillon 4,5x4,5m, abnehmbare Seitenteile mittels Reißverschlüssen, mit wenigen Handgriffen aufgebaut. Ideal für Events im Outdoor Bereich mit ausreichendem Platz. Gebläse und Bodenverankerung inklusive.

 Auditorium Tent on measure 4,5x4,5 m. Ideal for organizing outdoor events. Includes a continuous air motor that is positioned outside the inflatable. Supplied with strings and pins for the floor. Quick and easy assembly.

 Tente auditorium de mesure 4,5x4,5m. Idéale pour l'organisation d'événements extérieurs. Inclus un moteur d'air continu qui se situe à l'extérieur de la structure. Cordes et chevilles pour fixer au sol incluses. Facile et rapide à monter.

 Tenda auditório de 4,5x4,5m. Ideal para a organização de eventos exteriores. Inclui um motor de ar contínuo no exterior do insuflável. Inclui cordas e cravelhas para fixar ao solo. Fácil de montar.

 Carpa Auditorio en medida 4,5x4,5m. Ideal para la organización de eventos de exterior. Incluye un motor de aire continuo que se sitúa en el exterior del hinchable. Se suministra con cuerda y clavijas para fijar al suelo. Fácil y rápido montaje.



4.5x4.5x2.9m



15.169 4500x4500x2900mm

OUTDOOR ASHTRAYS

4

Outdoor Ashtray

Outdoor Aschenbecher. Gehäuse: Edelstahl. Oben / Unten: Aluminium. Schlüssel und Schrauben sind zum Öffnen und Schließen enthalten. Aluminium, Edelstahl.

Outdoor Ashtray. Body: made of stainless steel. Top / Bottom: Aluminium alloy. Includes opening/closing key and screws.

Cendrier extérieur fabriqué en acier inoxydable et aluminium. S'ouvre et se ferme avec clef. Clef inclus.

Cinzeiros de exterior. Corpo: aço inoxidável de 1,0. Parte superior/inferior: liga de alumínio. Chave e parafusos incluídos. Material: alumínio e aço oxidável.

Cenicero para exterior en acero inoxidable. Apertura y cierre con llave. Incluye tonillos. Material: Aluminio y acero inoxidable.

Beresford



13.288

Popkum



13.284

Paulson

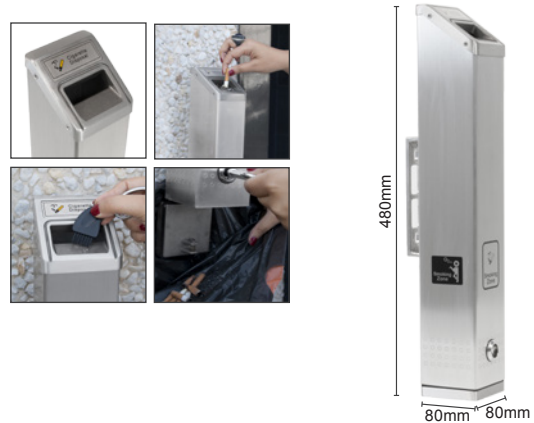

13.285

Sunbury



13.286

Fendale



13.287

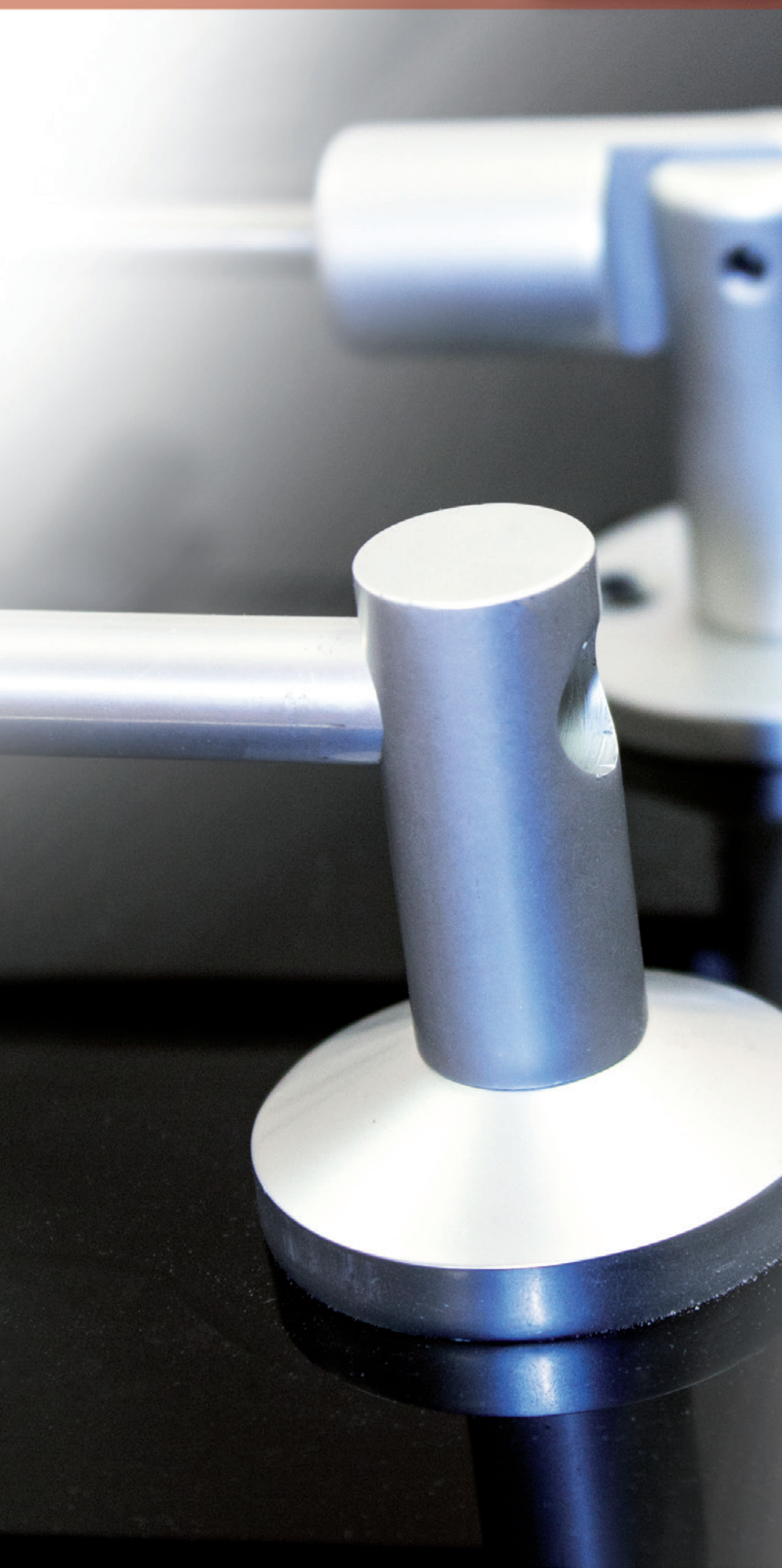

CABLE KIT

Alpha	212
Delta	213
Gamma	214
Epsilon	215
Free Standing	216
Acrylic Pocket	217

Alpha

Stahlseil-Präsentationssystem. Ideal für jedes Schaufenster.

Information and communication system with steel cable. Ideal for use in shop windows, shops, etc...

Système d'informations et communication avec câble d'acier. Idéal pour vitrines, magasins, etc.

Sistema de cabo de aço moderno e prático que permite uma montagem rápida e fácil de exposições e displays. O sistema é composto por tensores, cabos e pinças de diferentes formatos e tamanhos e pasta sem acrílico para diferentes tipos de documento.

Sistema de información y comunicación con cable de acero. Ideal para su uso en escaparates, tiendas, etc.



Cable System

Seilsystem 3m. Drahtseil mit 2 verchromten Plattenhaltern.

For suspending from ceiling to floor. Consists of 3m steel cable, 1 ceiling fixing and 1 floor fixing. Material: Steel.

Kit complet de 3m. Câble+ 2 tenseurs (chromé- brillant) pour une fixation directe ou sur rail.

Sistema de cabos para suspender do tecto até ao chão. Inclui cabo de 3 metros, 1 tensor de tecto e outro de solo. Material: Aço.

Kit completo 3m. cable + 2 tensores (cromo-brillo) directos o para carril.



12.119 Floor / Ceiling fixing

Ceiling Fixing

Verchromter Decken- oder Bodenhalter.

For aluminium track. Colour: chrome. Stainless steel.

Tenseur, chromé brillant supérieur ou inférieur.

Tensor cromo-brilho superior ou inferior.

Tensor cromo-brillo superior ó inferior.

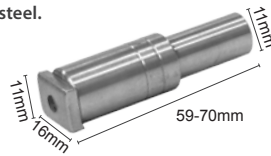

12.120 x10

Wire Cable

25m Stahlseil-Rolle, Durchmesser 1mm.

Diameter: 1mm. Length of roll: 25m. Steel cable.

Câble d'acier tressé, 1mm de diamètre, en bobine de 25m.

Cabo de aço entrançado em bobinas de 25m.

Cable de acero trenzado, 1mm de diámetro, en bobinas de 25m.

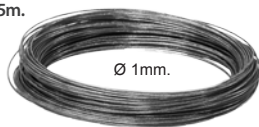

12.121 Ø 1mm x 25m

Aluminium Load

Aluminium Gegengewicht.

Aluminium load for cable system. Aluminium.

Contrepoids en aluminium.

Contrapeso em alumínio.

Contrapeso de aluminio.



12.117 Ø 40x170mm

Clips

Verchromter Plattenhalter mit Gelenk.

Panel clip for cable system.

Pince simple de fixation pour les latéraux.

Pinça fixa para laterais.

Pinza fija sencilla para laterales.

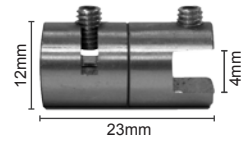

12.122 x10

Verchromter Plattenhalter mit Gelenk.

For holding two vertical adjacent panels from the cable system.

Pince de fixation double pour l'intérieur.

Pinça fixa dupla para interiores.

Pinza fija doble para interiores.

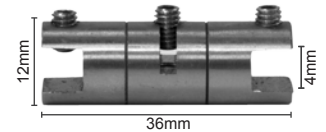

12.123 x10

Einseitiger Plattenhalter zur Aufhängung.

Wall fixing clip.

Pince de fixation directe au mur.

Pinça fixa directa para parede.

Pinza fija directa para pared.

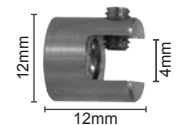

12.124 x10

Aluminium Track

Aluminiumschiene, als Deckenbefestigung oder frei hängend.

Aluminium track for cable system. Length: 2m or 3m.

Rail mobile en aluminium supérieur (de plafond) ou inférieur.

Carril de alumínio móvel, superior (de tecto) ou inferior.

Carril de aluminio superior (de techo) o inferior móvil.

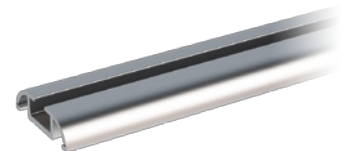

12.127 2000mm

12.128 3000mm

Delta

Stahlseil-Präsentationssystem aus verchromtem Stahl. Ideal für alle Arten von Verkaufs- und Ausstellungsräumen wie z.B. Reise- und Immobilienbüros.

Cable and tension system. Modern and practical cable and tension which allows you to quickly and easily set up acrylic pockets. The system is made of tensioners and cables ceiling/floor or wall/wall, an extensive range of grips. Finished in chrome.

Système de communication et d'information avec câble en acier. Idéal pour une utilisation en vitrine, mur, agence de voyages, immobilière, etc. finition en acier chromé.

Sistema de cabo de aço moderno e prático que permite uma montagem rápida e fácil de pastas em acrílico. O sistema inclui tensores, cabos para tecto/chão e parede/parede e uma variada gama de pinças. Acabamento cromado.

Sistema de comunicación e información con cable de acero. Ideal para el uso en escaparates, paredes, agencias de viaje, inmobiliarias, etc. Terminación en acero cromado.

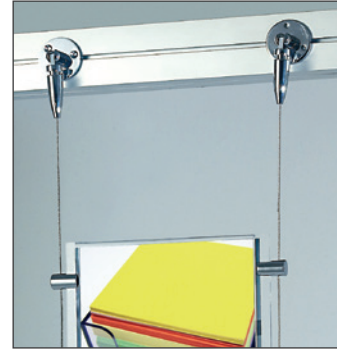

Wall Mounting Clip for Ceiling/Wall

Winkel-Seilspanner für Wand- oder Deckenbefestigung. Geeignet für Stahlseil mit 1,5mm Durchmesser.

Wall mounting for ceiling/wall. With joint for cable system. For cable of 1.5mm. Finish: Chrome.

Support mobile pour mur ou plafond. Convient pour un câble de 1.5mm de diamètre.

Suporte basculante para parede ou tecto para cabo de 1,5 mm. Acabamento cromado.

Soporte móvil para pared o techo. Apto para cable de 1,5mm de diámetro.

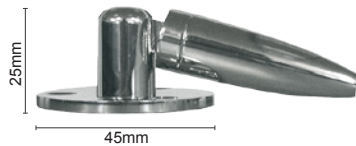

12.316

x4

Vertical Panel Clip

Einseitiger Plattenhalter, vertikale Nutzung. Geeignet für Stahlseil mit 1,5 oder 3mm Durchmesser. Acrylplattenstärke bis zu 6mm.

Holds vertical panels up to 6mm thick. For cable of 1.5mm to 3mm. Finish: Chrome.

Pince simple vertical, idéale pour la fixation de portes affiches en acrylique jusque 6mm d'épaisseur. Convient pour un câble de 1.5 à 3 mm d'épaisseur.

Pinça simple vertical para colocar pastas em acrílico com uma espessura máxima de 6mm. Adequado para cabo de 1,5mm ou 3mm.

Pinza sencilla vertical ideal para la colocación de carpetas acrílicas de hasta 6mm de espesor. Apto para cable de 1,5mm ó 3mm.

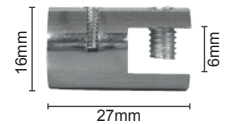

12.318

x10

Wall Mounting Clip for Ceiling/Floor

Decken- oder Bodenhalter für Stahlseil mit 1,5 oder 3mm Durchmesser.

Wall mounting for ceiling/floor. With joint for cable system. For cable of 1.5mm to 3mm. Finish: Chrome.

Support fixe pour plafond ou sol. Convient pour un câble de 1,5 ou 3mm.

Suporte basculante para chão ou tecto para cabo de 1,5 ou 3mm. Acabamento cromado.

Soporte fijo para techo o suelo. Apto para cable de 1,5mm ó 3mm.

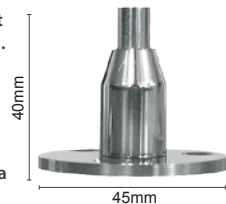

12.317

x4

Double Panel Clip

Doppelseitiger Plattenhalter für Displaystärke bis zu 6mm.

Diameter: 1.5mm. Length of roll: 25m. Material: Steel cable.

Pince double verticale, idéale pour la fixation de portes affiches en acrylique allant jusqu'à 6mm d'épaisseur.

Pinça dupla vertical ideal para colocar pastas em acrílico com uma espessura máxima de 6mm.

Pinza doble vertical ideal para la colocación de carpetas acrílicas de hasta 6mm de espesor.

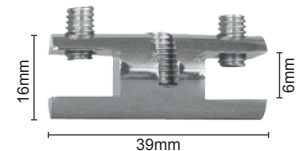

12.319

x10

Wire Cable

Stahlseil geflochten, 1,5mm Durchmesser. Rolle 25m.

Diameter: 1.5mm. Length of roll: 25m. Material: Steel cable.

Câble en acier tressé, 1,5 mm de diamètre. Rouleau de 25m.

Cabo de aço entrançado com 1,5mm de diâmetro. Bobinas 25m.

Cable de acero trenzado, 1,5mm de diámetro. Bobinas de 25m.



12.315

Ø 1.5mm x 25m

Wire Cable

Stahlseil geflochten, 3mm Durchmesser. Rolle 25m.

Diameter: 3mm. Length of roll: 25m. Material: Steel cable.

Câble en acier tressé, 3 mm de diamètre. Rouleau de 25m.

Cabo de aço entrançado com 3mm de diâmetro. Bobinas 25m.

Cable de acero trenzado, 3mm de diámetro. Bobinas de 25m.



12.311

Ø 3mm x 25m

Gamma

 Stahlseil-Präsentationssystem aus naturbelassenem Aluminium. Ideal für die Gestaltung von Schaufenstern und Wänden.

 Cable and tension system. Modern and practical cable and tension system kit with steel cable. Ideal for use on windows, walls, etc.. Posted in "natural" aluminium.

 Système de communication et d'information avec câble d'acier. Idéal pour l'usage en vitrines, murs, etc. Fabriqué en aluminium «naturel».

 Sistema de cabo de aço moderno e prático que permite uma montagem rápida e fácil de exposições, displays, montras de loja, etc. O sistema inclui pinças, tensores e cabos. Alumínio prateado natural.

 Sistema de comunicación e información con cable de acero. Ideal para el uso en escaparates, paredes, etc. Fabricado en aluminio "natural".

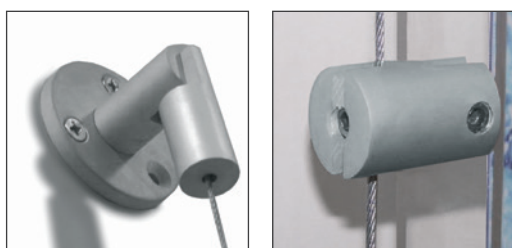

Wall Mounting Top Clip

 Winkel-Seilspanner für Wand- oder Deckenbefestigung. Geeignet für Stahlseil mit 1,5 oder 3mm Durchmesser.

 Movable support for wall/ceiling with joint for cable system. For cable wire up to 1.5-3mm thickness.

 Support mobil de mur/plafond pour la fixation d'un câble de 1.5 ou 3mm d'épaisseur.

 Suporte superior para parede tecto para fixação de um cabo com uma espessura de 1,5mm ou 3mm.

 Soporte móvil superior de pared/techo para la sujeción de un cable de grosor 1,5mm ó 3mm.

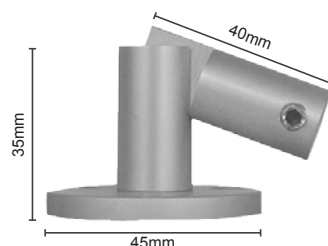



12.312

x4 

Wall Mounting Bottom Clip

 Winkel-Seilspanner für Wand- oder Deckenbefestigung. Geeignet für Stahlseil mit 1,5 oder 3mm Durchmesser.

 Movable support for wall/ceiling for the subjection of 1.5 or 3mm thickness cable. Colour: natural silver. Aluminium.

 Support mobil inferieur de mur/plafond pour la fixation d'un câble de 1.5 ou 3mm d'épaisseur.

 Suporte inferior para parede / tecto para fixação de um cabo com uma espessura de 1,5mm ou 3mm.

 Soporte móvil inferior de pared/techo para la sujeción de un cable de grosor 1,5mm ó 3mm.

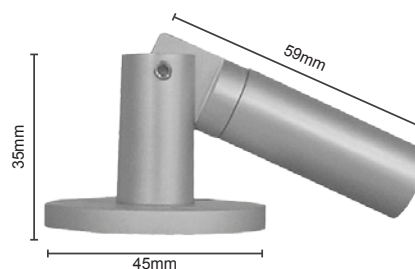

12.313

x4 

Vertical Panel Clip

 Einseitiger Plattenhalter, vertikale Nutzung. Geeignet für Stahlseil mit 1,5 oder 3mm Durchmesser. Plattenstärke bis zu 6mm.

 For cable system. Holds up to 6mm thick panels. Colour: natural silver. Material: Aluminium.

 Pince simple verticale pour la fixation d'un porte affiche. Pour un câble de 1,5 ou 3mm d'épaisseur. Permet la fixation de matériaux allant jusqu'à 6mm d'épaisseur.

 Pinça simple vertical para a fixação de uma porta-impressão. Permite a utilização de um cabo de 1,5mm ou 3mm. Fixa material com uma espessura até 6mm.

 Pinza sencilla vertical para sujeción de una portagráfica. Para un grosor de cable de 1,5mm ó 3mm. Permite la sujeción de material de hasta 6mm de espesor.

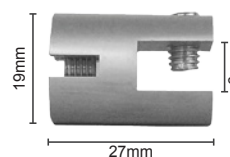

12.314

x10 

Epsilon

Stahlseil-Präsentationssystem aus verchromtem Stahl. Geeignet für Stahlseil mit 1,5 oder 3mm Durchmesser. Ideal für die Gestaltung von Wänden in Verkaufs- oder Ausstellungsräumen.

Wire communication system. Ideal for travel agencies, real estate, banks, etc.. Suitable for cable diameter 1.5 to 3mm. Finished in chromed steel.

Système de communication par câble. Idéal pour les agences de voyages, immobilières, banques, etc. Convient pour des câbles de 1,5 ou 3mm de diamètre. Finition en acier chromé.

Sistema de cabo de aço moderno e prático que permite uma montagem rápida e fácil de pastas em acrílico. O sistema inclui tensores, cabos para tecto/chão e parede/parede e uma variada gama de pinças. Acabamento cromado.

Sistema de comunicación por cable. Ideal para agencias de viaje, inmobiliarias, bancos, etc. Válido para cable de 1,5 ó 3mm de diámetro. Terminación en acero cromado.

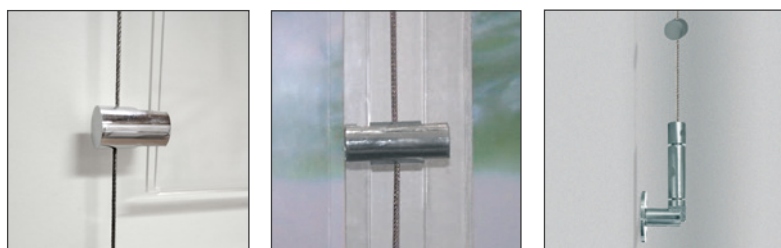

Wall-Mounting Clip

Winkel-Seilspanner für Wand- oder Deckenbefestigung.

Movable support for wall/ceiling with joint for cable system.

Support mobil supérieur pour la fixation de câbles sur un mur ou plafond.

Suporte basculante para parede ou tecto para cabo de 1,5 mm. Acabamento cromado.

Soporte móvil superior para fijación de cable en paredes o techos.

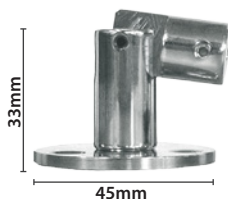

12.320

x4

Vertical Panel Clip

Einseitiger Plattenhalter, vertikale Nutzung. Geeignet für Stahlseil mit 1,5 oder 3mm Durchmesser. Acrylplattenstärke bis zu 6mm.

Holds vertical panels up to 6mm thick. For cable of 1.5mm to 3mm. Finish: Chrome.

Pince simple vertical, idéal pour la fixation de portes affiches en acrylique allant jusqu'à 6mm d'épaisseur. Apte pour des câbles de 1,5 ou 3 mm.

Pinça simples vertical para colocar pastas em acrílico com uma espessura máxima de 6mm. Adequado para cabo de 1,5mm ou 3mm.

Pinza sencilla vertical ideal para la colocación de carpetas acrílicas de hasta 6mm de espesor. Apto para cable de 1,5mm ó 3mm.

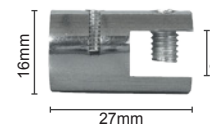

12.318

x10

Wall-Mounting Clip

Winkel-Seilspanner mit Wandabstandshalter zur Befestigung an Wand, Decke oder am Aluminiumprofil.

Movable support for wall/ceiling with joint for cable system.

Support mobil supérieur pour la fixation de câbles sur un mur ou plafond. Possibilité de l'adapter à un profil en aluminium.

Suporte inferior basculante para cabo de 1,5 mm. Acabamento cromado.

Soporte móvil inferior para fijación de cable en paredes o techos. Posibilidad de acoplar a perfiles de aluminio.

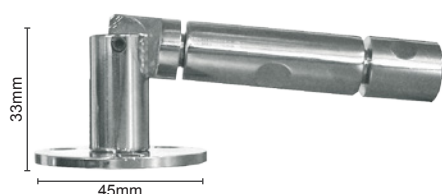

12.321

x4

Double Panel Clip

Doppelseitiger Plattenhalter, ideal für Acrylplattenstärke bis zu 6mm.

For holding two vertical adjacent panels up to 6mm thick in the cable system. Finish: Chrome.

Pince double verticale, idéal pour la fixation de portes affiches en acrylique allant jusqu'à 6mm d'épaisseur.

Pinça dupla vertical ideal para colocar pastas em acrílico com uma espessura máxima de 6mm.

Pinza doble vertical ideal para la colocación de carpetas acrílicas de hasta 6mm de espesor.

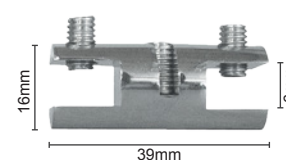

12.319

x10

Free Standing

Display-Ständer als Aluminiumrahmen mit verchromten Füßen und Seilsystem. Fußmodule justierbar. System besteht aus Rahmengestell, Seilspannern, Plattenhaltern und Stahlseil mit 1,5mm Durchmesser. Acrylplatten nicht inklusive.

Cable support system for aluminum frame with chrome feet and levels. The system consists of racks, clamps, pliers and wire 1.5 mm in diameter. Methacrylate Folders not included. Material: Aluminium, plastic, steel cable.

Système de câble sur support coulissant en aluminium, avec pieds chromés et réglables. Le système se compose de coulisses, tenseurs, pinces et câble de 1,5mm de diamètre. Portes affiches acryliques non incluses.

Sistema de cabos sob suporte bastidor de alumínio com patas cromadas e niveladoras. O sistema é composto por bastidores, tensores, pinças e cabo de 1,5mm de diâmetros. Pastas em acrílico não incluídas.

Sistema de cables sobre soporte bastidor de aluminio con patas cromadas y niveladores. El sistema se compone de bastidores, tensores, pinzas y cable de 1,5mm de diámetro. Carpetas de metacrilato no incluidas.

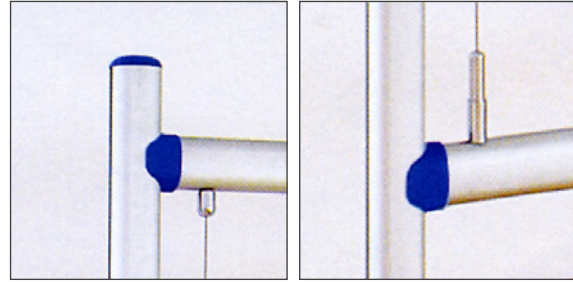

Free Standing 900x2120mm

Enthält:

- Rahmengestell: 1
- Seilspanner oben: 4
- Seilspanner unten: 4
- Einseitiger Plattenhalter: 24
- Doppelseitiger Plattenhalter: 24
- Stahlseil: 1,5mm: 8,8m

Conteúdo:

- Bastidor: 1
- Tensor superior: 4
- Tensor inferior: 4
- Pinça simples: 24
- Pinça dupla: 24
- Cabo 1,5mm: 8,8m

Includes:

- Framework: 1
- Top tensioner: 4
- Bottom tensioner: 4
- Single panel clip: 24
- Double panel clip: 24
- Cable 1.5mm: 8,8m

Contenido:

- Bastidor: 1
- Tensor superior: 4
- Tensor inferior: 4
- Pinza simple: 24
- Pinza doble: 24
- Cable 1,5mm: 8,8m

Contenu:

- Coulisse: 1
- Tenseur supérieur: 4
- Tenseur inférieur: 4
- Pince simple: 24
- Pince double: 24
- Câble 1.5mm: 8,8m

12.354 900x2120mm

Free Standing 1200x2120mm

Enthält:

- Rahmengestell: 1
- Seilspanner oben: 5
- Seilspanner unten: 5
- Einseitiger Plattenhalter: 24
- Doppelseitiger Plattenhalter: 36
- Stahlseil: 1,5mm: 10,6m

Conteúdo:

- Bastidor: 1
- Tensor superior: 5
- Tensor inferior: 5
- Pinça simples: 24
- Pinça dupla: 36
- Cabo 1,5mm: 10,6m

Includes:

- Framework: 1
- Top tensioner: 5
- Bottom tensioner: 5
- Single panel clip: 24
- Double panel clip: 36
- Cable 1.5mm: 10,6m

Contenido:

- Bastidor: 1
- Tensor superior: 5
- Tensor inferior: 5
- Pinza simple: 24
- Pinza doble: 36
- Cable 1,5mm: 10,6m

Contenu:

- Coulisse: 1
- Tenseur supérieur: 5
- Tenseur inférieur: 5
- Pince simple: 24
- Pince double: 36
- Câble 1.5mm: 10,6m

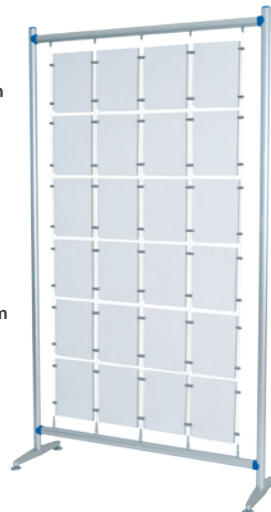

12.355 1200x2120mm

Free Standing 1500x2120mm

Enthält:

- Rahmengestell: 1
- Seilspanner oben: 6
- Seilspanner unten: 6
- Einseitiger Plattenhalter: 24
- Doppelseitiger Plattenhalter: 48
- Stahlseil: 1,5mm: 12,72m

Conteúdo:

- Bastidor: 1
- Tensor superior: 6
- Tensor inferior: 6
- Pinça simples: 24
- Pinça dupla: 48
- Cabo 1,5mm: 12,72m

Includes:

- Framework: 1
- Top tensioner: 6
- Bottom tensioner: 6
- Single panel clip: 24
- Double panel clip: 48
- Cable 1.5mm: 12,72m

Contenido:

- Bastidor: 1
- Tensor superior: 6
- Tensor inferior: 6
- Pinza simple: 24
- Pinza doble: 48
- Cable 1,5mm: 12,72m

Contenu:

- Coulisse: 1
- Tenseur supérieur: 6
- Tenseur inférieur: 6
- Pince simple: 24
- Pince double: 48
- Câble 1.5mm: 12,72m

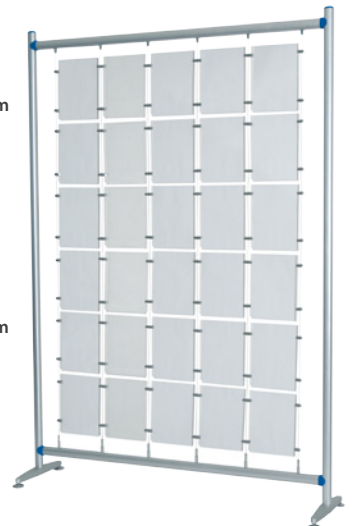

12.356 1500x2120mm

ACRYLIC POCKET

Acrylic Pocket

Transparente Acryltaschen in DIN A4 und A3, vertikal oder horizontal nutzbar.

Pocket Folder for landscape or portrait position, in transparent acrylic A4 and A3 size.

Portes affiches en acrylique transparents horizontaux ou verticaux en format A3 ou A4.

Pasta em acrílico transparente horizontal ou vertical em tamanho A4 e A3.

Carpeta de metacrilato transparente horizontal o vertical en tamaño A4 y A3.



12.125	A4 Horizontal	x10		
12.351	A3 Horizontal	x10		
12.126	A4 Vertical	x10		
12.352	A3 Vertical	x10		

DIN Sizes

A0	841x1189mm	A4	210x297mm	A8	52x74mm
A1	594x841mm	A5	148x210mm	A9	37x52mm
A2	420x594mm	A6	105x148mm	A10	26x37mm
A3	297x420mm	A7	74x105mm		

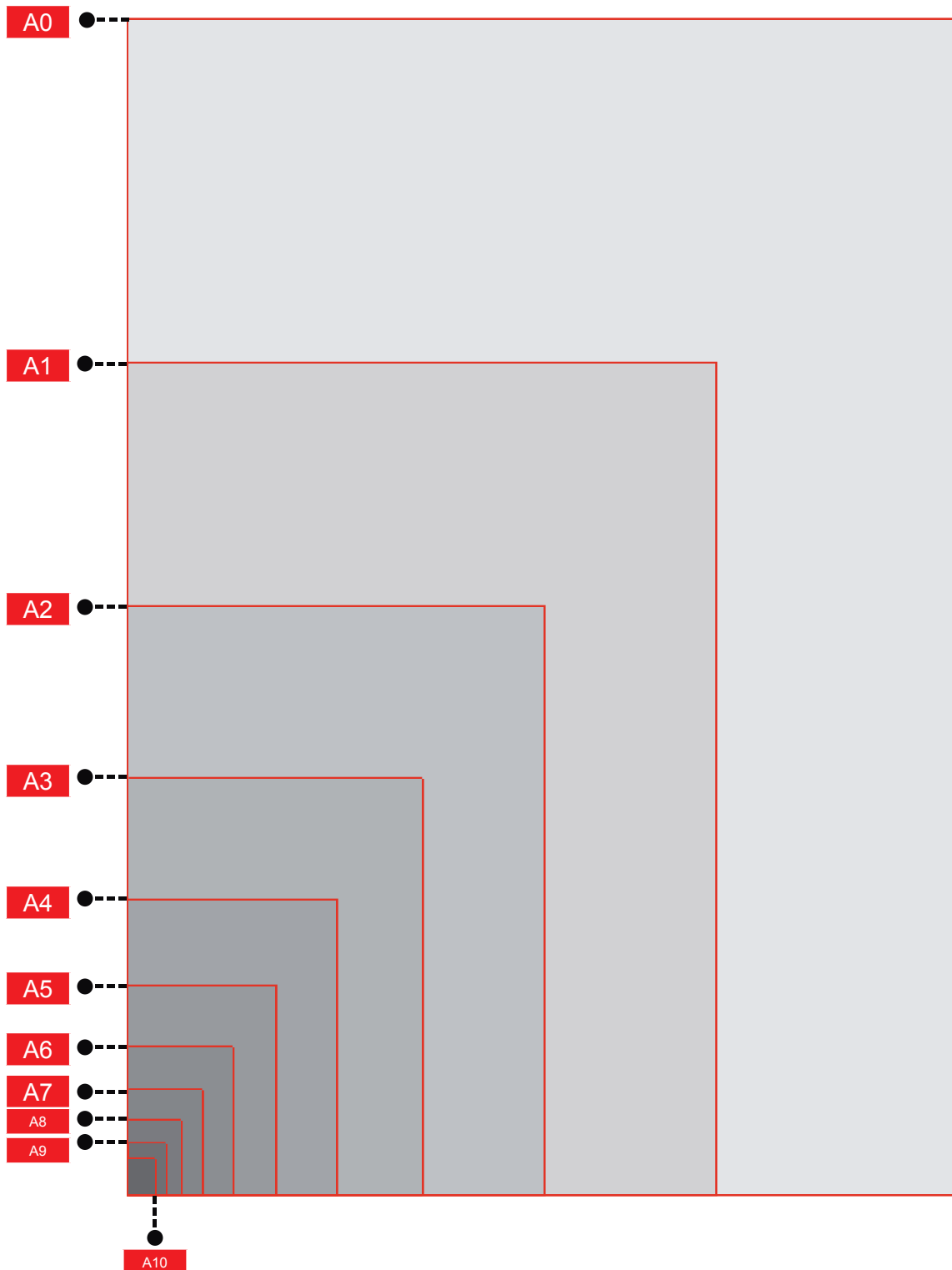



WHITE BOARDS & SCREENS

Boards	222
Flipcharts	223
Wooden Boards	224
Showcases	226
Outdoor Showcases - Accessories	228

Enamelled Whiteboard

Deutschland Weißwandtafel magnetisch, mit eloxiertem Aluminiumrahmen und Kunststoffecken, einseitig nutzbar, Stärke 18mm, Rückwand verzinkt. Mit Tafelmarkern beschreibbar und trocken wieder abwischbar. Grafikbefestigung mittels Magneten. Inklusive Ablageschale für Marker und Zubehör. Verfügbar in 5 Größen.

United Kingdom Whiteboard, framed in anodized aluminum, thickness 18 mm, plastic corners and galvanized rear. Includes pen holder tray. Allows writing with dry erasable markers or placing documents using magnets. Easy to clean. Available in 5 sizes.

France Tableau blanc, simple face, encadré en aluminium anodisé, épaisseur 18mm, angle en plastique et dos galvanisé. Plateau pour marqueurs inclus. Permet l'écriture avec marqueurs effaçables à sec ou à la pose de documents à l'aide d'aimants. Facile à nettoyer. Disponible en 5 dimensions.

Portugal Quadro branco, uma face emoldurado em alumínio anodizado, espessura 18mm, cantos de plástico e traseira galvanizada. Inclui um suporte para os marcadores. Permite a escrita com marcadores, podendo limpar-se a seco ou colocar documentos mediante um íman. Fácil de limpar. Disponível em 5 tamanhos.

Spain Pizarra blanca, una cara enmarcada en aluminio anodizado, grosor 18mm, cantoneras de plástico y trasera galvanizada. Incluye bandeja porta rotuladores. Permite la escritura con rotuladores borrables en seco o la colocación de documentos mediante imanes. Fácil limpieza. Disponible en 5 tamaños.

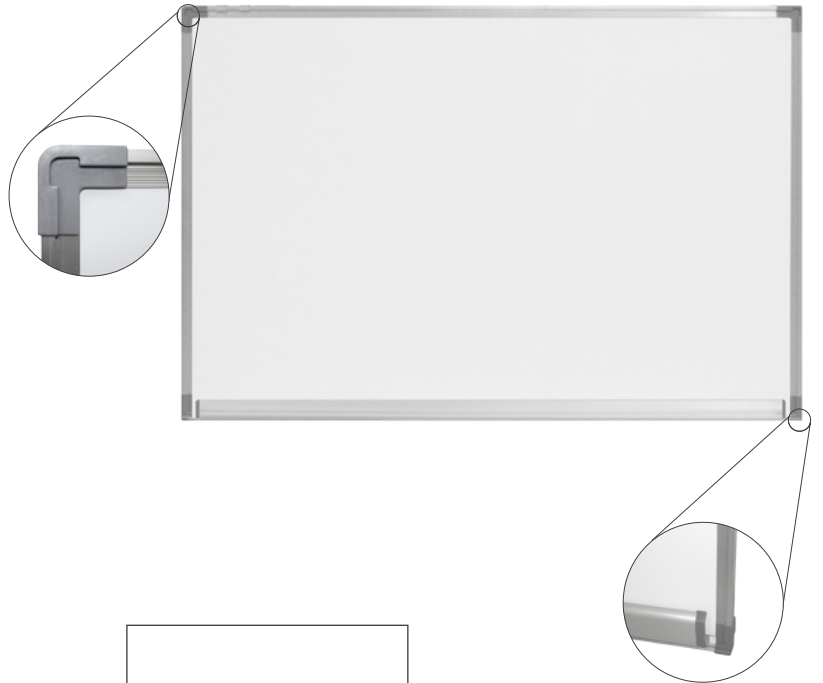

14.000	900x600mm	
14.001	1200x900mm	
14.002	1500x1200mm	
14.003	1800x1200mm	
14.004	2000x1200mm	

Cork Board

Deutschland Korktafel mit eloxiertem Aluminiumrahmen und Kunststoffecken, Korkstärke 8mm. Grafikbefestigung mittels Pinn-Nadeln oder Reißzwecken. Ideal zum Anpinnen von Notizen. Verfügbar in 6 Größen.

United Kingdom Cork board equipped with silver anodized aluminium frame and grey plastic rounded corners. Ideal for pinning up notes, notices, posters, etc. Cork thickness 8mm. Available in 6 sizes.

France Tableau en liège, encadré en aluminium avec angle en plastique. Idéal pour la fixation de notes, documents, etc. Fixation de documents à l'aide d'épingles, ou de punaises. Epaisseur du liège 8mm. Disponible en 6 dimensions.

Portugal Quadro de cortiça com esquadria de alumínio e esquinas em plástico. Ideal para colocar notas, avisos, posters, etc. Material: alumínio, plástico e cortiça.

Spain Tablero de corcho enmarcado en aluminio con cantoneras de plástico. Ideal para la fijación de notas, documentos, etc. Fijación de documentos mediante alfileres o chinchetas. Grosor del corcho 8mm. Disponible en 6 tamaños.





14.008	600x450mm	
14.009	900x600mm	
14.010	1200x900mm	
14.011	1500x900mm	
14.012	1500x1200mm	
14.013	1800x1200mm	

Flipchart

 Flipchart mit Kunststoffrahmen und höhenverstellbarem Dreibeinstativ aus Stahl, in Schwarz. Magnethaftende Oberfläche. Aufhängung und Ablage für Marker inklusive. Oberfläche: 680x940mm. Aufstellhöhe bis ca: 1850mm.

 Flipchart Magnetic whiteboard with tripod made of steel painted in black. Framed in plastic. Includes clamp and bolts for installing pads. Adjustable tripod holder and pen tray. Board size 680x940mm. Maximum height: 1850mm.

 Tableau blanc magnétique, avec trépied, fabriqué en acier peint noir. Encadré en plastique. Inclus pinces et boulons pour la fixation de blocs. Trépied réglable et plateau marqueurs. Superficie du tableau: 680x940. Hauteur maximale: 1850mm.

 Tripé ajustável em altura equipado com quadro. A sua superfície está preparada para marcadores. Cor: preto. Material: Aço e plástico.

 Pizarra blanca magnética con trípode realizado en acero pintado en negro. Enmarcada en plástico. Incluye pinza y pernos para la colocación de blocs. Trípode graduable y bandeja porta rotuladores. Superficie de pizarra: 680x940mm. Altura máxima: 1850mm.

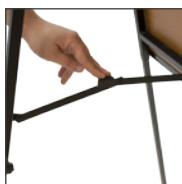



14.019 700x1030mm

Revolving Whiteboard

 Mobile Weißwandtafel magnetisch, mit eloxiertem Aluminiumrahmen und Kunststoffecken, doppelseitig nutzbar. Tafel drehbar gelagert. Verfügbar in 3 Größen.

 Trippable magnetic double sided whiteboard, framed with aluminum and plastic corners. Anchor system to secure the board vertically. Includes wheels and markers holder tray. Available in 3 sizes.

 Tableau magnétique réversible, double face, encadré avec profil en aluminium et angles en plastique. Système d'ancrage pour fixer le tableau en position verticale. Inclus, roulettes et plateau porte-marqueurs. Disponible en trois dimensions.

 Quadro magnético reversível de dupla face, emoldurado com um perfil de alumínio e cantos em plástico. Sistema que permite a fixação do quadro na vertical. Inclui rodas e bandeja para rotuladores. Disponível em três tamanhos.

 Pizarra volteable magnética de doble cara, enmarcada con perfil de aluminio y cantoneras de plástico. Sistema de anclaje para fijar la pizarra en posición vertical. Incluye ruedas y bandeja porta rotuladores. Disponible en 3 tamaños.

Revolving



14.020 600x900mm

14.021 1500x1200mm

14.022 1800x1200mm



WOODEN BOARDS

6

Marker Board

 Aufstell-Tafel mit lackiertem Holzrahmen und ausklappbarer Stütze hinten, einseitig nutzbar.

 Board sided easel, made of varnished wood, with rear foot.

 Chevalet ardoise, une face, fabriqué en bois vernis, avec pied arrière.

 Cavalete em ardósia com esquadria em madeira.

 Caballete pizarra a una cara, fabricada en madera barnizada, con pata trasera.



10.170 500x700mm

10.171 700x1000mm

Chalkboard with Feet

 Doppelseitige Aufstell-Tafel mit mahagonifarbenem Holzrahmen und Füßen.

 Chalkboard easel with feet, double-sided, made of wood. Color Mahogany.

 Chevalet ardoise avec pieds, double face, fabriqué en bois. Couleur acajou.

 Cavalete dupla face com quadro e duas patas fabricado em madeira. Color Mogno.

 Caballete pizarra con patas, a 2 caras, fabricado en madera. Color Caoba.

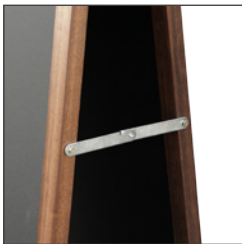



14.047 495x685mm





Chalkboard without Feet

 Doppelseitige Aufstell-Tafel mit mahagonifarbenem Holzrahmen, ohne Füße. Verfügbar in 2 Größen.

 Chalkboard easel slate floor, double-sided, made of wood. Available in 2 sizes. Color Mahogany.

 Chevalet ardoise de sol, double face, fabriqué en bois. Disponible en 2 dimensions. Couleur acajou.

 Cavalete de ardósia de dupla face sem patas. Disponível em dois tamanhos diferentes. Cor: Mogno. Material: Madeira.

 Caballete pizarra a suelo, a 2 caras, fabricado en madera. Disponible en 2 medidas. Color Caoba.



14.048 560x1200mm

14.049 560x1700mm





Tripod Board

 Mahagonifarbene Staffelei aus Holz.

 Chalkboard for wall on one side, made of natural varnished wood.

 Chevalet pour tableau, fabriqué en bois. Couleur Acajou.

 Tripé de madeira. Color: Mogno. Material: Madeira.

 Caballete para pizarra, fabricado en madera. Color Caoba.





14.056 Height: 1650mm

Chalkboard

 Wandtafel mit lackiertem Holzrahmen, einseitig nutzbar.

 Chalkboard equipped with natural wood frame. Material: Wood.

 Tableau pour mur, simple face, fabriqué en bois vernis.

 Quadro em ardósia com esquadria em madeira.

 Pizarra para pared a una cara, fabricada en madera barnizada.



10.350

A4

10.351

A3

10.352

A2

Chalkboard

 Wandtafel mit mahagonifarbenem Holzrahmen. Verfügbar in 4 Größen.

 Wall mount chalkboard a face made of wood. Available in 4 sizes. Color: Mahogany.

 Cadre ardoise pour mur, simple face, fabriqué en bois. Disponible en quatre dimensions. Couleur acajou.

 Quadro em ardósia com esquadria em madeira. Disponível em vários tamanhos.

 Marcos pizarra a pared una cara, fabricados en madera. Disponible en 4 tamaños. Color Caoba.

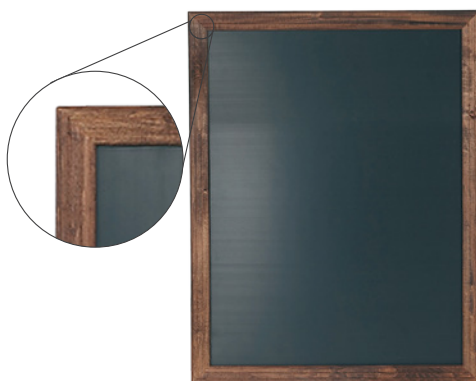

14.050 560x1000mm

14.051 560x1200mm

14.052 560x1500mm

14.053 560x1700mm

Showcase with Swing Door

 Schaukasten aus Aluminium und Acrylglastür mit Sicherheitsschloss. Verfügbar mit Kork- oder Magnettafel. Ideal zum Aushängen von Informationen.

 Swing door showcase with cork background or magnetic white metal sheet. Made of silver anodized aluminium. Includes acrylic lockable door. Ideal for pinning up notes or magnets.

 Vitrine pour annonces avec fond en liège ou magnétique. Cadre en aluminium et porte en acrylique avec serrure. Idéal pour la fixation de documents à l'aide de punaises ou aimants.

 Vitrina com fundo de cortiça ou magnético. Fabricada em alumínio anodizado. Possui fechadura. Material: Alumínio e acrílico.

 Vitrina para anuncios con fondo de corcho o metálico. Marco de aluminio y puerta de metacrilato con cerradura. Ideal para la fijación de documentos mediante chinchetas o imanes.

Hessen



14.092	250x400mm	
14.045	350x500mm	
14.046	500x700mm	
14.093	600x600mm	

*Hintergrund Metall.
Background: Metal.
Fond: Métal.
Fundo: Metal.
Fondo metálico.

Bayern





*Hintergrund Kork.
Background: Cork.
Fond: Liège.
Fundo: Cortiça.
Fondo: Corcho.

14.090	250x400mm	
14.043	350x500mm	
14.044	500x700mm	
14.091	600x600mm	

Rostock

 Schaukasten aus Aluminiumrahmen und transparentem Kunststoff. Rückwand als Kork. Seitliche Diebstahlsicherung. Die ideale Lösung zum Aushängen wichtiger Dokumente und Mitteilungen.

 Showcase for announcements, made of cork, for wall placement. Aluminum frame and PVC front. Side Locker. Ideal for attaching notes, documents, messages, etc., through pins.

 Vitrine pour annonces avec fond en liège, pour une fixation au mur. Cadre en aluminium et façade en PVC. Fermeture latérale. Idéal pour la fixation de notes, documents, messages, etc., à l'aide de punaises.

 Vitrina para anúncios fabricada em cortiça para colocar na parede. Marco de alumínio y frontal em PVC. Fechadura lateral. Ideal para a fixação de notas, documentos, mensagens entre outros com pioneses.

 Vitrinas para anuncios, realizadas en corcho, para su colocación en pared. Marco de aluminio y frontal en PVC. Cerradura lateral. Ideal para la fijación de notas, documentos, mensajes, etc., mediante chinchetas.

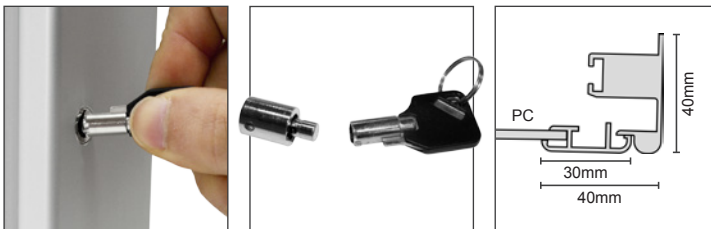

14.084	500x700mm	<input type="text"/>
14.085	600x800mm	<input type="text"/>
14.086	700x1000mm	<input type="text"/>

Wissmar

 Schaukasten aus Aluminiumrahmen und transparentem Kunststoff. Rückwand als Magnettafel. Seitliche Diebstahlsicherung. Die ideale Lösung zum Aushängen wichtiger Dokumente und Mitteilungen.

 Showcase for announcements, made of magnetic, for wall placement. Aluminum frame and PVC front. Side Locker. Ideal for attaching notes, documents, messages, etc., through magnets.

 Vitrine pour annonces avec fond en magnétique, pour une fixation au mur. Cadre en aluminium et façade en PVC. Fermeture latérale. Idéal pour la fixation de notes, documents, messages, etc., à l'aide de aimants.

 Vitrina para anúncios fabricada em material magnético para colocar na parede. Marco de alumínio y frontal em PVC. Fechadura lateral. Ideal para a fixação de notas, documentos, mensagens entre outros com imans.

 Vitrinas para anuncios, realizadas en magnéticas, para su colocación en pared. Marco de aluminio y frontal en PVC. Cerradura lateral. Ideal para la fijación de notas, documentos, mensajes, etc., mediante imanes.

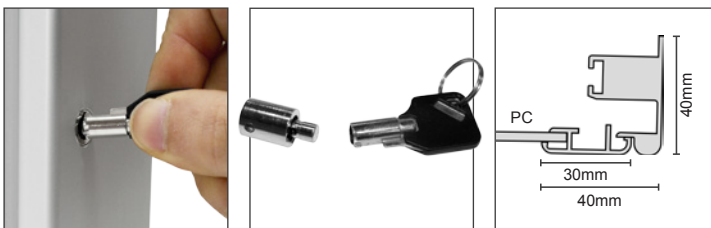



14.087	500x700mm	<input type="text"/>
14.088	600x800mm	<input type="text"/>
14.089	700x1000mm	<input type="text"/>

OUTDOOR SHOWCASES - ACCESSORIES

6

Showcase Metz

 Gutschein für Magnet Anzeigen für die Platzierung an der Wand oder Boden. Aluminiumrahmen und gehärtetem Glas 3 mm dick. Side Sperren. Wasserdicht. Ideal zum Befestigen von Notizen, Dokumente, Nachrichten, etc., Mit Magneten.

 Display showcase for announcements magnetic for placement on the wall or floor. Aluminum frame and tempered glass 3mm thickness. Side Locker. Water resistant. Ideal for attaching notes, documents, messages, etc., through magnets.

 Vitrine pour annonces avec fond fabriqué magnétique, pour une fixation sur un mur ou au sol. Cadre en aluminium et verre trempé de 3 mm d'épaisseur. Serrure latérale. Résiste à l'eau. Idéal pour la fixation de notes, documents, messages, etc., à l'aide de d'aimants.

 Vitrina para anuncios, fabricadas em magnético, para colocar em paredes ou chão. Marco de Alumínio e vidro temperado de 3 mm de espessura. Fechadura lateral. Resistente à água. Ideal para a fixação de notas, documentos, mensagens entre outros com imanes.

 Vitricas para anuncios magnéticas, para su colocación en pared o suelo. Marco de aluminio y cristal templado de 3mm de espesor. Cerradura lateral. Resistente al agua. Ideal para la fijación de notas, documentos, mensajes, etc., mediante imanes.



*Hintergrund Metall.
Background: Metal.
Fond: Métal.
Fundo: Metal.
Fondo metálico.

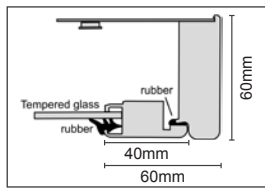

*FüÙe nicht enthalten.
Base feet not included.
Poteaux non inclus.
Base no incluida.
Base no incluida.



14.058	1000x840mm	
14.059	750x1090mm	
14.060	750x660mm	
14.061	1150x940mm	
14.064	850x1240mm	

Whiteboard Accessories

Magnets

 Magneten, farbig sortiert. In 3 Größen verfügbar.

 Magnets for blackboard. Assorted colors. Available in 3 sizes.

 Aimants pour tableau. Plusieurs couleurs. Disponible en trois dimensions.

 Imanes para quadro. Várias cores. Disponível em 3 tamanhos.

 Imanes para pizarra. Colores surtidos. Disponible en 3 tamaños.



14.031	Ø 20mm	x12	
14.032	Ø 30mm	x6	
14.033	Ø 40mm	x4	

Pins

 Pinnadeln 100 Stück, farbsortiert.

 Each Box contains of 100 pins. Assorted colors.

 Boite de 100 punaises de couleurs différentes.

 Cada caixa contém 100 unidades de tachas de várias cores.

 Cada caja contiene 100 unidades de chinchetas en colores surtidos.



14.034

Eraser

 Tafelwischer aus Kunststoff für Weißwandtafel.

 Whiteboard eraser made of plastic.

 Effaceur pour tableau blanc, fabriqué en plastique.

 Apagador para quadros brancos fabricado em plástico.

 Borrador para pizarras blancas realizado en plástico.

14.030





LEAFLET DISPENSERS

Menu Card Holder	230
Leaflet Dispenser	236
Poster Snap	237
Acrylic Pocket Sandwich	238
Table Display	239
Wood & Acrylic	241
Acrylic Display	242
Catalogue Acrylic Display	244
Coin Box	245
Wall Mounting Dispenser	246
Literature Holder	248
Acrylic Stand	249
PVC Display	251
PVC Poster Display	253
PVC Leaflet Dispenser	254
Showcard Pocket	257
Leaflet Dispenser	258
Menubook	259
Wire Leaflet Dispenser	260
Acrylic Accessories	261

MENU CARD HOLDER

7

Menu Card Holder "T" Open

Menü-Kartenhalter "T" geöffnet. Material: Acryl.

Acrylic Menu card holder in the shape of a open and inverted "T".

Porte affiche en forme de "T" inversé et ouvert. Acrylique transparent.

Porta folhetos aberto em forma de "T" invertido. Acrílico.

Portagráfica en forma de "T" invertida. Material: Acrílico.

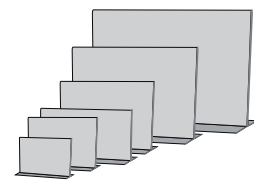
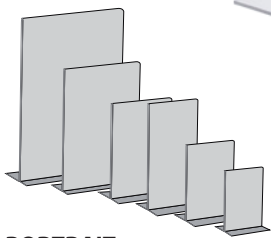
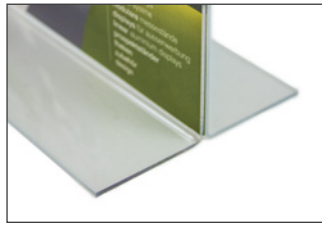
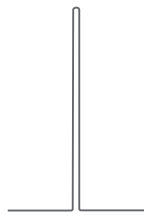
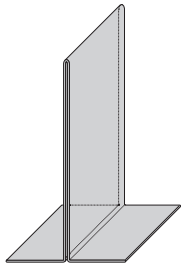

PORTRAIT





13.069P	A3	3mm	x5			
13.027P	A4	2mm	x10			
13.028P	A5	2mm	x10			
13.068P	A6	2mm	x10			
13.147P	A7	2mm	x10			
13.148P	1/3 A4	2mm	x10			

LANDSCAPE

13.069L	A3	3mm	x5			
13.027L	A4	2mm	x10			
13.028L	A5	2mm	x10			
13.068L	A6	2mm	x10			
13.147L	A7	2mm	x10			
13.148L	1/3 A4	2mm	x10			

MENU CARD HOLDER

Menu Card Holder "T" Closed

-  Menü-Kartenhalter "T" geschlossen. Material: Acryl.
-  Acrylic Menu card holder in the shape of a closed and inverted "T".
-  Porte affiche en forme de "T" fermé. Acrylique transparent.
-  Porta folhetos fechado em forma de "T" invertido. Acrílico.
-  Portagráfica en forma de "T" invertida. Material: Acrílico.

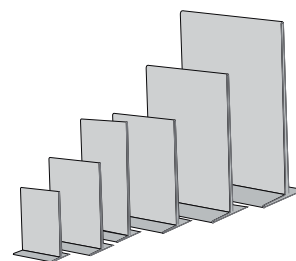
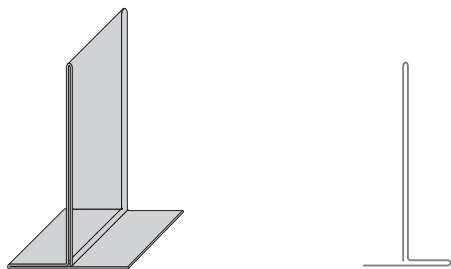





PORTRAIT

13.000	A3	3mm	x5 	<input type="text"/>
13.001	A4	2mm	x10 	<input type="text"/>
13.002	A5	2mm	x10 	<input type="text"/>
13.003	A6	2mm	x10 	<input type="text"/>
13.350	A7	2mm	x10 	<input type="text"/> 
13.351	1/3 A4	2mm	x10 	<input type="text"/> 

MENU CARD HOLDER

7

Acrylic "L" Display

-  Acryl-"L"-Display. Material: Acryl.
-  Acrylic "L" display. Material: Acrylic.
-  Acrylic display in shape of "L". Material Acrylic.
-  Porta folhetos em forma de "L". Material: Acrílico.
-  Portagráfica de sobremesa en "L". Material: Acrílico.

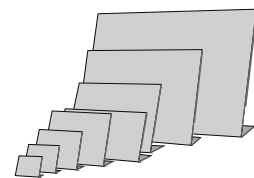
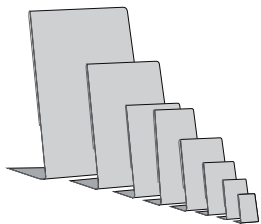
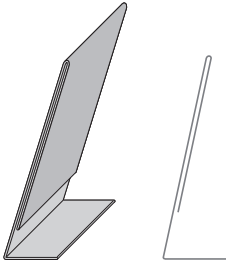

PORTRAIT





13.004P	A3	3mm	x5 		
13.005P	A4	2mm	x10 		
13.006P	A5	2mm	x10 		
13.007P	A6	2mm	x10 		
13.352P	A7	2mm	x10 		
13.353P	A8	2mm	x20 		
13.354P	A9	2mm	x20 		
13.355P	1/3 A4	2mm	x10 		

LANDSCAPE

13.004L	A3	3mm	x5 		
13.005L	A4	2mm	x10 		
13.006L	A5	2mm	x10 		
13.007L	A6	2mm	x10 		
13.352L	A7	2mm	x10 		
13.353L	A8	2mm	x20 		
13.354L	A9	2mm	x20 		
13.355L	1/3 A4	2mm	x10 		



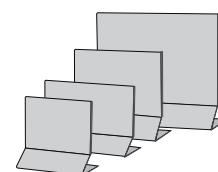
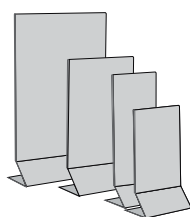
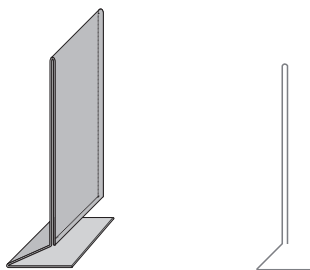

MENU CARD HOLDER

Menu Card Holder "Z"





-  Tischständer in Z - Form. Acryl-Material.
-  Menu card holder with shape of "Z". Material: Acrylic.
-  Porte affiche en forme de "Z". Acrylique transparent.
-  Porta folhetos em forma de "Z". Material: Acrílico.
-  Portagráfica en forma de "Z". Material: Acrílico.



PORTRAIT

13.008P	A4	2mm	x10 	<input type="text"/>
13.009P	A5	2mm	x10 	<input type="text"/>
13.010P	A6	2mm	x10 	<input type="text"/>
13.363P	1/3 A4	2mm	x10 	<input type="text"/> 

LANDSCAPE

13.008L	A4	2mm	x10 	<input type="text"/> 
13.009L	A5	2mm	x10 	<input type="text"/> 
13.010L	A6	2mm	x10 	<input type="text"/> 
13.363L	1/3 A4	2mm	x10 	<input type="text"/> 



Menu Card Holder "Snake"

🇩🇪 Menü-Kartenhalter "Triangle" Basis. Material: Acryl.

🇬🇧 Menu card holder with "Triangle" Base. Material: Acrylic.

🇫🇷 Porte affiche avec base triangulaire fabriqué en acrylique transparent.

🇵🇹 Porta folhetos com base triangular. Material: Acrílico.

🇪🇸 Portagráfica con base en forma triangular. Material: Acrílico.

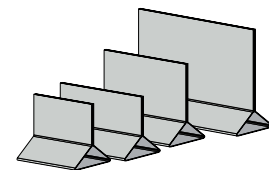
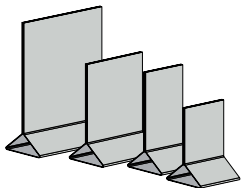
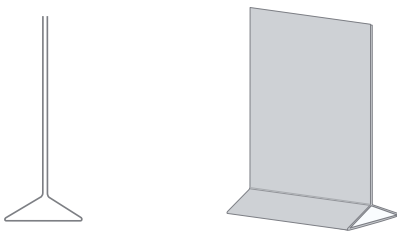

PORTRAIT





13.364P	A4	2mm	x10	<input type="text"/>
13.365P	A5	2mm	x10	<input type="text"/>
13.366P	A6	2mm	x10	<input type="text"/>
13.367P	1/3 A4	2mm	x10	<input type="text"/>

LANDSCAPE

13.364L	A4	2mm	x10	<input type="text"/>
13.365L	A5	2mm	x10	<input type="text"/>
13.366L	A6	2mm	x10	<input type="text"/>
13.367L	1/3 A4	2mm	x10	<input type="text"/>

MENU CARD HOLDER

Acrylic "L" Display With Black Frame

-  Acryl "L" Display mit schwarzem Druckrahmen. Material: Acryl.
-  Printing holder in "L" shape with black printed frame. Acrylic.
-  Porte affiche en L avec contour noir. Fabriqué en acrylique transparent.
-  Porta folhetos em forma de "L" com perfil em preto. Acrílico.
-  Portagráfica en forma de "L" con marco negro serigrafiado. Acrílico.







PORTRAIT

13.361P	A4	2mm	x5 	<input type="text"/>
13.362P	A5	2mm	x5 	<input type="text"/>

LANDSCAPE

13.361L	A4	2mm	x5 	<input type="text"/>
13.362L	A5	2mm	x5 	<input type="text"/>

Menu Card Holder With Independent Base

-  Tischständer aus 2mm Acrylglas mit separatem Fuß. Acryl-Material.
-  Menu card holder with independent base. Material: Acrylic.
-  Porte affiche avec socle indépendant. Acrylique transparent.
-  Porta folhetos com base independente. Material: Acrílico.
-  Portagráficas con base independiente. Material: Acrílico.

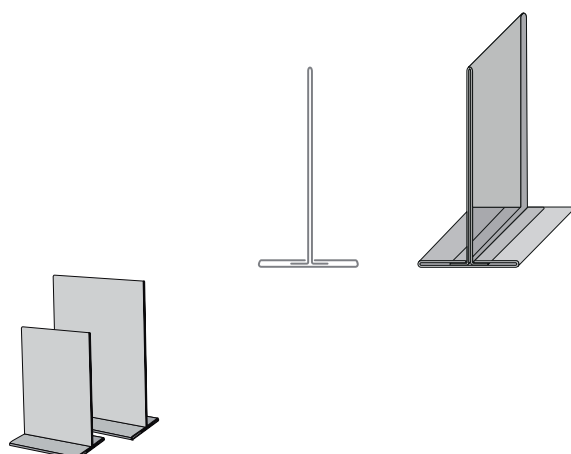

PORTRAIT

13.018	A4	2mm	x10 	<input type="text"/>
13.019	A5	2mm	x10 	<input type="text"/>



LEAFLET DISPENSER

7

L-Display A3 with Leaflet A6

L-Display A3 mit A6 Prospekthalter für Werbung.
Farbe: transparent. Material: Acryl.

L-Display A3 with A6 leaflet dispenser for advertising. Acrylic.

Porte Affiche A3 avec porte brochure A6.
Fabriqué en acrylique transparent.

Porta folhetos A3 em forma de "L" com divisória para folhetos A6 do lado direito. Material: Acrílico transparente.

L-Display A3 con cajetín A6 para colocar publicidad.
Material: Acrílico.

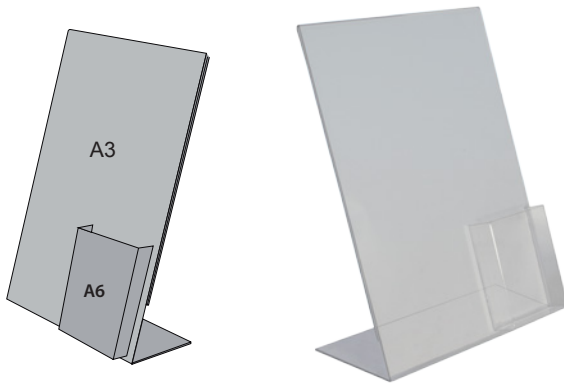

PORTRAIT

13.041 A3+ Leaflet A6 3mm (Leaflet 2mm) x5

L-Display A4 with Leaflet A6

L-Display A4 mit A6 Prospekthalter für Werbung.
Farbe: transparent. Material: Acryl.

L-display A4 with A6 leaflet dispenser for advertising. Acrylic.

Porta folhetos A4 em forma de "L" com divisória para folhetos A6 do lado direito. Material: Acrílico transparente.

Porta folhetos A4 em forma de "L" com divisória para folhetos A6 do lado direito. Material: Acrílico transparente.

L-Display A4 con cajetín A6 para colocar publicidad.
Material: Acrílico.

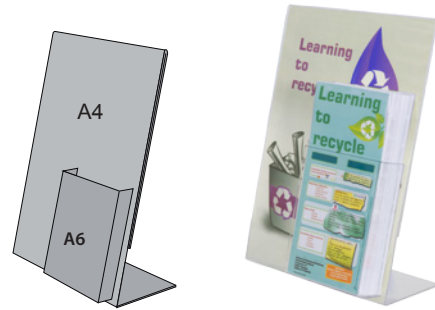

PORTRAIT

13.042 A4+ Leaflet A6 3mm (Leaflet 2mm) x5

L-Display A4 with Leaflet A5



L-Display A4 mit A5 Prospekthalter für Werbung.
Farbe: transparent. Material: Acryl.

L-display A4 with A5 leaflet dispenser on the right side. Transparent Acrylic.

Porte Affiche A4 avec porte brochure A5. Acrylique transparent.

Porta folhetos A4 em forma de "L" com divisória para folhetos A5 do lado direito. Material: Acrílico transparente.

L-Display A4 con cajetín A5 para colocar publicidad.
Material: Acrílico.



PORTRAIT

13.368 A4 + Leaflet A5 2mm (Leaflet 2mm) x5

L-Display A4 with Showcard Leaflet



A4 L-Display mit Box für Visitenkarten. Material: Acryl.

A4 L-Display with slipcase for business cards. Material: Acrylic.

Porte Affiche A4 avec support pour cartes de visites. Acrylique transparent.

Porta folhetos A4 em forma de "L" com divisória para folhetos. Acrílico transparente.

L-Display A4 con cajetín para tarjetas de visita. Material: Acrílico.

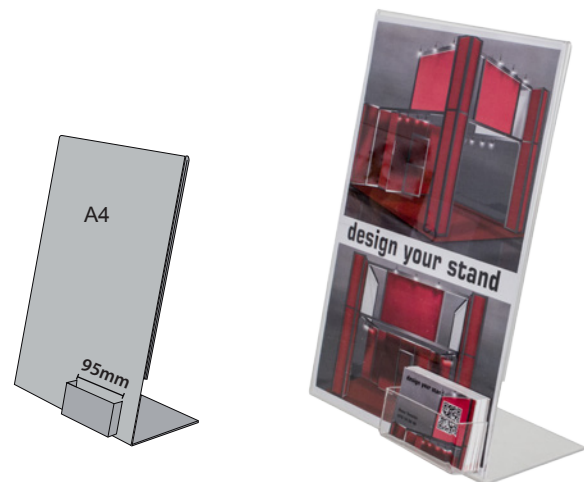

PORTRAIT

13.370 A4 + Showcard Leaflet 2mm (Leaflet 2mm) x5

POSTER SNAP

L-Display "Poster Snap"



- L-Display "Poster Snap" Acryl und Aluminium "clip". Farbe: transparent. Acryl.
- L-Display "Poster Snap" with upper clamping. Color: transparent. Acrylic.
- Porte visuel en acrylique transparent en forme de "L". Fixation par "clip".
- Porta folhetos em "L" com clip de alumínio. Acrílico transparente.
- Portagráficas "L" con pinza superior. Color: transparente. Acrílico.

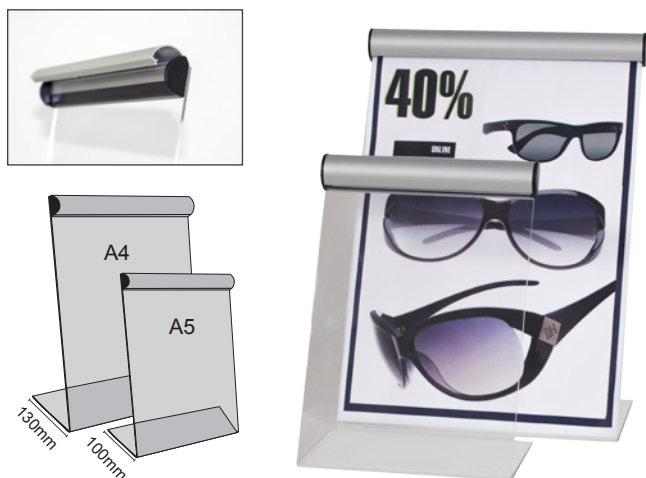

PORTRAIT

13.384	A4	2mm	x5		
13.385	A5	2mm	x5		

L-Display "Poster Snap" Magnetic Base



- L-Display "Poster Snap" Acryl und Aluminium "clip". Magnetfuß. Farbe: transparent. Acryl.
- L-Display "Poster Snap" with upper clamping. Magnetic base. Colour: transparent. Acrylic.
- Porte visuel en "L" avec base magnétique. Fixation par "clip". Fabriqué en acrylique transparent.
- Porta folhetos em "L" com clip de alumínio. Acrílico transparente.
- Portagráficas "L" con pinza superior. Base magnética. Color: Transparente. Acrílico.

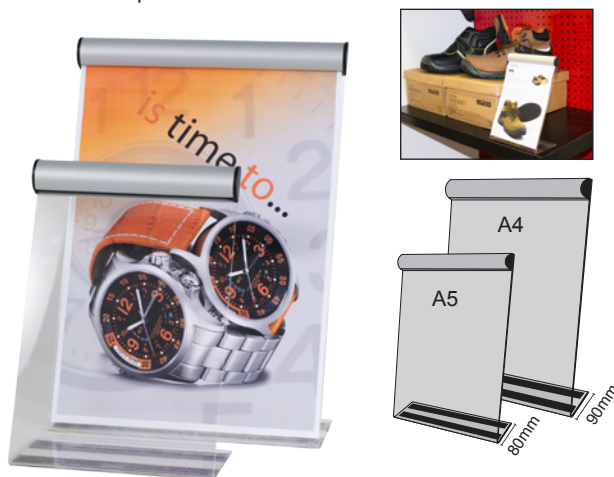

PORTRAIT

13.016	A4	2mm	x5		
13.017	A5	2mm	x5		

Acrylic Pocket "Wall Sandwich"

- Acryl-Tasche "Wall Sandwich". Farbe: transparent. Material: Acryl.
- Acrylic "Wall Sandwich" display for placing on the wall. Color: transparent.
- Pochette en acrylique transparent «Wall Sandwich».
- Mica transparente para suspender. Material: Acrílico.
- Portagráficas "Sandwich" para colocar sobre pared. Color: transparente. Material: Acrílico.



PORTRAIT

13.371P	A3	2mm	x5		
13.372P	A4	2mm	x5		
13.373P	A5	2mm	x5		

LANDSCAPE

13.371L	A3	2mm	x5		
13.372L	A4	2mm	x5		
13.373L	A5	2mm	x5		

ACRYLIC POCKET SANDWICH

7

Acrylic Pocket "Sandwich"

🇩🇪 Grafikhalter hängend, Acryl-Material.
Das Produkt wird ohne Löcher geliefert.

🇬🇧 Printing holder to hang from the ceiling.
Color: transparent. Material: Acrylic.
The product is supplied without holes.

🇫🇷 Porte affiche "Sandwich" fabriqué en acryliques transparent.
Le produit se fixe avec des pinces.

🇧🇷 Mica transparente. Material: Acrílico.
Furos não incluídos.

🇪🇸 Portagráfica para colgar al techo.
Color: transparente. Material: Acrílico.
El producto se suministra sin agujeros.

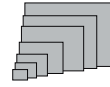
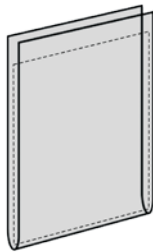
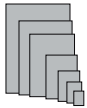

PORTRAIT

13.020P	A1	2mm	x5	<input type="checkbox"/>
13.021P	A2	2mm	x5	<input type="checkbox"/>
13.022P	A3	2mm	x5	<input type="checkbox"/>
13.023P	A4	2mm	x10	<input type="checkbox"/>
13.024P	A5	2mm	x10	<input type="checkbox"/>
13.025P	A6	2mm	x10	<input type="checkbox"/>
13.026P	700x500mm	2mm	x5	<input type="checkbox"/>

LANDSCAPE

13.020L	A1	2mm	x5	<input type="checkbox"/>	NEW
13.021L	A2	2mm	x5	<input type="checkbox"/>	NEW
13.022L	A3	2mm	x5	<input type="checkbox"/>	NEW
13.023L	A4	2mm	x10	<input type="checkbox"/>	NEW
13.024L	A5	2mm	x10	<input type="checkbox"/>	NEW
13.025L	A6	2mm	x10	<input type="checkbox"/>	NEW
13.026L	700x500mm	2mm	x5	<input type="checkbox"/>	NEW

Acrylic Pocket "Sandwich" With Suction Cup

🇩🇪 Acryl-Tasche "Sandwich" mit Saugnapf. Farbe: Transparent.
Material: Acryl.

🇬🇧 "Sandwich" Printing Holder with suction cups. Color: transparent. Acrylic.

🇫🇷 Porte affiche "Sandwich" avec ventouse fabriqué en acrylique transparent.

🇧🇷 Mica transparente com ventosas. Material: Acrílico.

🇪🇸 Portagráficas "Sandwich" con ventosas. Color: transparente. Material: Acrílico.

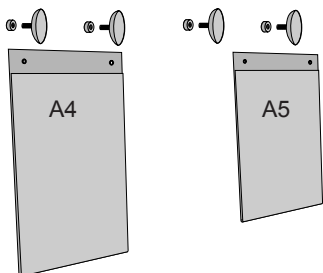

PORTRAIT

13.376	A4-Sheet	2mm	x5	<input type="checkbox"/>
13.397	A5-Sheet	2mm	x5	<input type="checkbox"/>

Duo Acrylic Display

- Doppeltes Acryl-Display. Farbe: transparent. Material: Acryl.
- Duo acrylic display. Colour: transparent. Material: Acrylic.
- Porte affiche "duo" fabriqué en acrylique transparent.
- Acrílico transparente duplo.
- Portagráficas doble de sobremesa. Color: transparente. Material: Acrílico.

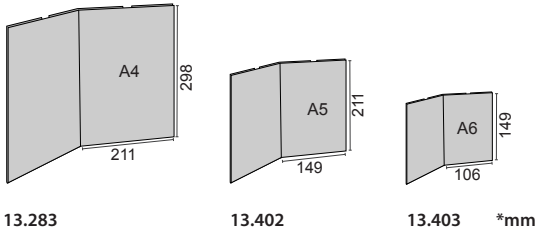

PORTRAIT

13.283	A4 x 2	2mm	x5		
13.402	A5 x 2	2mm	x5		
13.403	A6 x 2	2mm	x5		

Triangle Acrylic Display

- Dreieckiges Acryl-Display. Farbe: transparent. Material: Acryl.
- Triangle acrylic display. Colour: transparent. Material: Acrylic.
- Porte affiche triangulaire fabriqué en acrylique transparent.
- Acrílico transparente de forma triangular.
- Portagráficas Triangular de sobremesa. Color: transparente. Material: Acrílico.

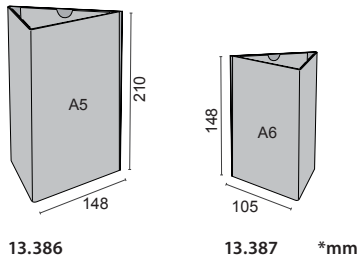

PORTRAIT

13.386	A5 x 3	2mm	x4		
13.387	A6 x 3	2mm	x4		

Square Acrylic Display

- Viereckiges Acryl-Display. Farbe: transparent. Material: Acryl.
- Square acrylic display. Colour: transparent. Material: Acrylic.
- Porte affiche carré fabriqué en acrylique transparent.
- Acrílico transparente de forma cuadrada.
- Portagráficas Cuadrada de sobremesa. Color: Transparente. Material: Acrílico.

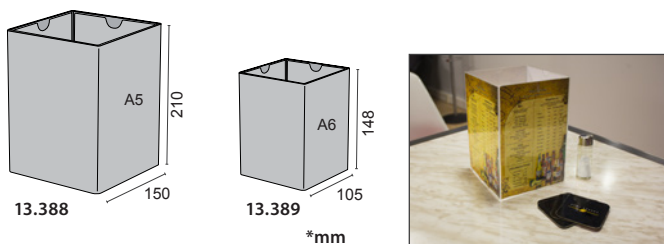

PORTRAIT

13.388	A5 x 4	2mm	x4		
13.389	A6 x 4	2mm	x4		

TABLE DISPLAY

7

Acrylic Y-Shaped Display

Y-Form Acryl-Display. Farbe: transparent. Material: Acryl.

Acrylic Y-Shaped display. Colour: transparent. Material: Acrylic.

Porte affiche en Y fabriqué en acrylique transparent.

Acrílico transparente em forma de "Y".

Portagráficas "Y" de sobremesa. Color: transparente. Material: Acrílico.

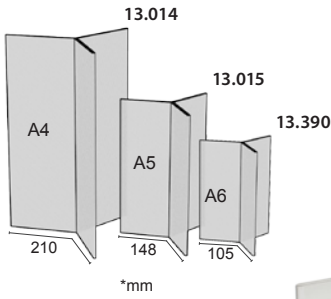

PORTRAIT

13.014	A4	2mm	x5	<input type="text"/>
13.015	A5	2mm	x5	<input type="text"/>
13.390	A6	2mm	x5	<input type="text"/>

NEW

Acrylic Cross Display

Acryl "X"-Display. Farbe: transparent. Material: Acryl.

Acrylic "X" display. Colour: transparent. Material: Acrylic.

Porte affiche en X fabriqué en acrylique transparent.

Acrílico transparente em forma de "X".

Portagráficas "X" de sobremesa. Color: Transparente. Material: Acrílico.

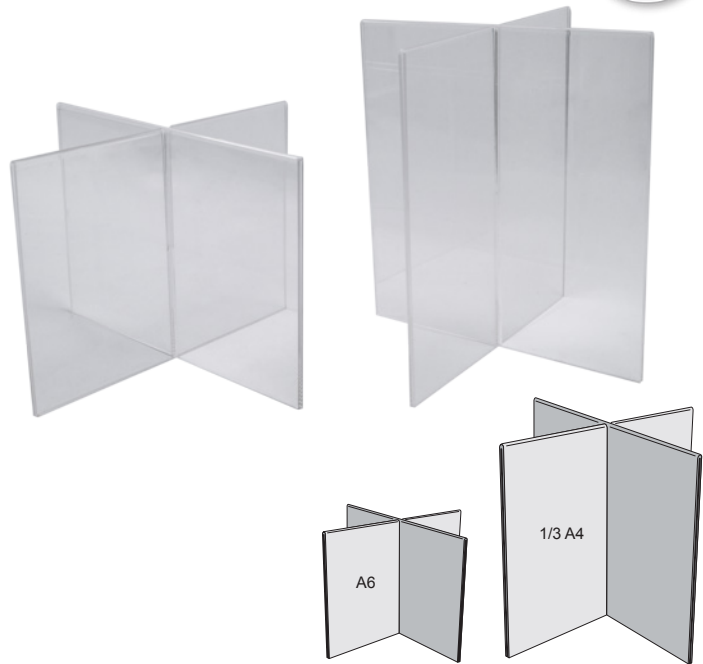

NEW

PORTRAIT

13.437	A6	2mm	x5	<input type="text"/>
13.438	1/3 A4	2mm	x5	<input type="text"/>

Menu Card Holder "Rectangular Wood"

Menü-Kartenhalter "Rectangular Wood". Natürliche Holzbasis. Farbe: transparent. Material: Holz und Acryl.

Menu card holder made with rectangular wooden base. Color: transparent. Material: Wood and acrylic.

Porte affiche en acrylique transparent, disposant d'une base rectangulaire en bois.

Porta folhetos em acrílico com base de madeira quadrada.

Portagráfica con base rectangular de madera. Color: transparente. Material: Madera y acrílico.

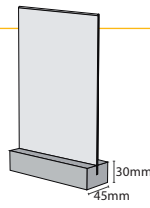

PORTRAIT

13.011P	A4	2mm	x10		
13.012P	A5	2mm	x10		
13.013P	A6	2mm	x10		

LANDSCAPE

13.011L	A4	2mm	x10		
13.012L	A5	2mm	x10		
13.013L	A6	2mm	x10		

Menu Card Holder "Oval Wood"

Menü-Kartenhalter "Oval Wood". Natürliche Holzbasis. Farbe: transparent. Material: Holz und Acryl.

Menu card holder with oval wooden base. Natural wooden base. Colour: transparent. Material: Wood and Acrylic.

Porte affiche en acrylique transparent, disposant d'une base en bois de forme ovale.

Porta folhetos em acrílico com base de madeira ovalada.

Portagráfica con base ovalada de madera. Color: transparente. Material: Madera y acrílico.

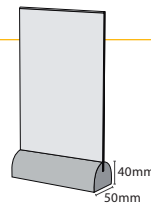

PORTRAIT

13.391P	A4	2mm	x10		
13.392P	A5	2mm	x10		
13.393P	A6	2mm	x10		

LANDSCAPE

13.391L	A4	2mm	x10		
13.392L	A5	2mm	x10		
13.393L	A6	2mm	x10		

Acrylic Brochure Stand



- Acryl Prospektständer. Farbe: transparent. Material: Acryl.
- Acrylic brochure stand. Colour: transparent. Material: Acrylic.
- Support pour catalogues ou livres fabriqué en acrylique transparent.
- Suporte em acrílico transparente para catálogos.
- Soporte acrílico para catálogos. Color: Transparente. Material: Acrílico.



PORTRAIT

13.380	210x200x40mm	4mm	x5		
13.381	105x150x40mm	4mm	x5		

Wall Acrylic Pocket



- Wandacryltasche mit zwei versenkten Bohrungen zur Befestigung an der Wand. Farbe: transparent. Material: Acryl.
- Wall acrylic pocket with two countersunk holes for attaching to wall. Color: Transparent. Material: Acrylic.
- Porte Brochures à fixer au mur. Acrylique transparent.
- Suporte de parede para catálogos. Possui furos escareados. Acrílico transparente.
- Portacatálogo acrílico con agujeros avellanados para fijación a pared. Color: Transparente. Material: Acrílico



PORTRAIT

13.382	A4	4mm	x5		
13.383	A5	4mm	x5		

Menu Card Holder "M"

- Menükarten - Klemme in M-Form. Material: Acryl.
- Menu card holder in "M" shape. Colour: Transparent. Material: Acrylic.
- Support pour porte visuel en forme de "M". Matériel: Acrylique.
- Suporte para porta-impressões em forma de "M". Material: Acrílico.
- Soporte para portagráficas en forma de "M". Transparente. Acrílico.

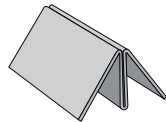

LANDSCAPE

13.035	210mm / A4	2mm	x10		
13.036	148mm / A5	2mm	x10		
13.037	105mm / A6	2mm	x10		

Menu Card Holder "Volcano"



- Menü-Kartenhalter "Volcano". Farbe: Transparent. Acryl.
- Menu card holder "Volcano". Colour: Transparent. Acrylic.
- Support pour porte visuel "Volcano". Acrylique.
- Suporte para porta-impressões "Volcano". Acrílico.
- Soporte para portagráficas "Volcano". Color: Transparente. Material: Acrílico.



LANDSCAPE

13.394	210mm / A4	2mm	x10		
13.395	148mm / A5	2mm	x10		
13.396	105mm / A6	2mm	x10		

Menu Card Holder "Luxe"

- Menükarten - Klemme aus Polystyrol.
- Menu card holder "Luxe". Made of injected polystyrene. Graphic maximum 2mm.
- Support pour porte visuel. Fabriqué en polystyrène injecté.
- Suporte para porta-impressões. Fabricados em poliestireno injectado.
- Soporte para portagráficas. Fabricados en poliestireno injectado. Máximo de gráfica 2mm.

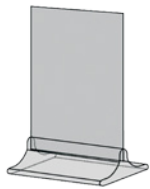

PORTRAIT

13.034 A5 x10

Acrylic Tend Display

- Acryl-Display doppelseitig. Mit 2 Einsätzen. Farbe: transparent. Material: Acryl.
- Acrylic tent display, double-sided. Material: Transparent acrylic.
- Support style chevalet double face, pour visuel. Fabriqué en acrylique transparent.
- Porta-impressões de dupla face. Material: Acrílico.
- Portagráficas de doble cara. Color: Transparente. Material: Acrílico.

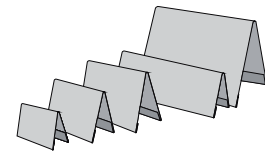
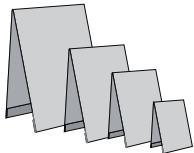
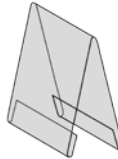





LANDSCAPE

PORTRAIT

13.029P	A4	2mm	x10	
13.030P	A5	2mm	x10	
13.031P	A6	2mm	x10	
13.032P	A7	2mm	x10	

13.029L	A4	2mm	x10	
13.030L	A5	2mm	x10	
13.031L	A6	2mm	x10	
13.032L	A7	2mm	x10	
13.033L	297x105mm	2mm	x10	

L-Display With Ring Binder



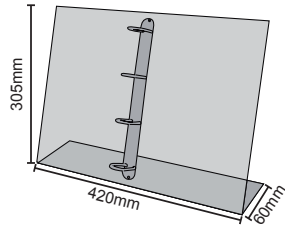

-  Für DIN A4-Hoch-Formate, mit vier Perforationen. Farbe: transparent. Material: Acryl.
-  A4 Vertical display with rings. Color: transparent. Material: Acrylic.
-  Porte catalogue A4, style classeur, format portrait. Fabriqué en acrylique transparent.
-  Porta folhetos em acrílico transparente com anilhas.
-  Portacatálogos vertical con anillas. Color: Transparente. Material: Acrílico.



PORTRAIT

13.043 A4 + A4 3mm x2 

"Bridge" Display with Ring Binder

-  Für DIN A4-Quer-Formate, mit vier Perforationen. Material: 3mm Acryl. Farbe: transparent. Material: Acryl.
-  For A4 Landscape sheets with 4 perforations. Material: 3mm transparent acrylic.
-  Porte catalogue A4, style classeur, format paysage. Fabriqué en acrylique transparent.
-  Porta folhetos horizontal com anilhas. Acrílico transparente de 3mm.
-  Portacatálogos horizontal con anillas. Color: Transparente. Material: Acrílico.

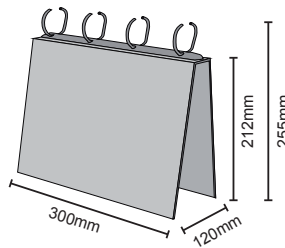





LANDSCAPE

13.404 A4 + A4 3mm x2 



Desktop Dispenser

-  Ablagekorb für A4 Hochformat Prospekte. Farbe: Transparent. Acryl.
-  Tray Document holder. Color: transparent. Acrylic.
-  Distributeur, de table, pour brochures A4. Fabriqué en acrylique transparent.
-  Bandeja para documentos de tamanho A4. Acrílico transparente.
-  Bandeja portadocumentos. Color: Transparente. Acrílico.

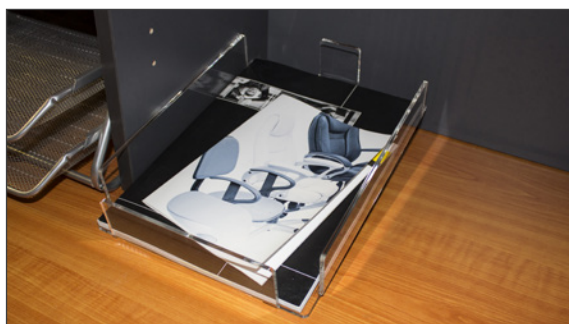

13.405 A4 4mm x2 

Coin Box

Aktionsbox aus Kunststoff mit Topschild für Grafik. Verfügbar mit oder ohne Sicherheitsverschluss. Acryl-Material.

Coin Box Acrylic urn. Available with or without locker. Material: Acrylic.

Urne d'acrylique avec porte visuels. Disponible avec ou sans serrure. Matériel: Acrylique.

Urna de acrílico com porta-impresões. Disponível com ou sem fecho. Material: Acrílico.

Urna de metacrilato con portagráficas. Disponible con y sin cerradura. Material: Acrílico.

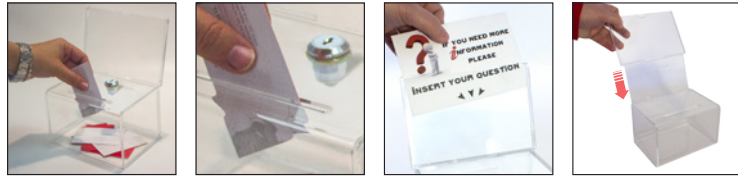

13.099



13.100 - With locker

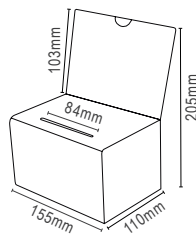

	QTY	N.W(kg)	G.W(kg)	C.B.M.	Size(mm)
Uni.	1	0.36	0.56	0.005	175x130x220
13.099	Graphic size: 150x100mm		Without lock		x2

	QTY	N.W(kg)	G.W(kg)	C.B.M.	Size(mm)
Uni.	1	0.32	0.52	0.005	175x130x220
13.100	Graphic size: 150x100mm		With lock		x2

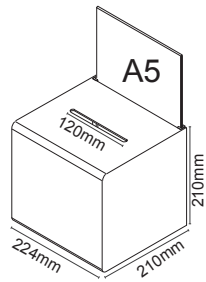
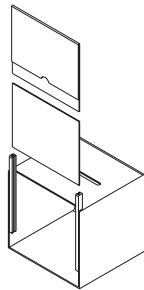

13.375	Graphic size: 180x207mm		With lock		x1
---------------	--------------------------------	--	------------------	--	----

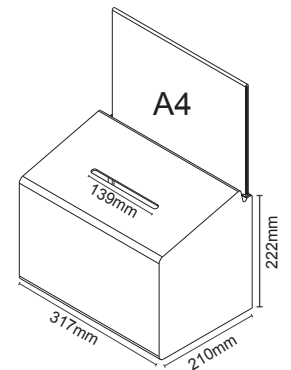
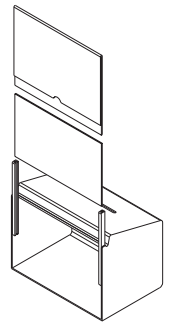

	QTY	N.W(kg)	G.W(kg)	C.B.M.	Size(mm)
Uni.	1	1.7	1.9	0.022	290x240x330
13.124	Graphic size: 300x210mm		With lock		x1

WALL MOUNTING DISPENSER

7

Single Wall Mounting Dispenser

🇩🇪 Prospekthalter aus Kunststoff für Tisch oder Wand. Polystyrol-Material.

🇬🇧 Simple Dispenser for using on desktop or wall. Polystyrene.

🇫🇷 Porte catalogue simple que l'on peut poser sur une table ou fixer au mur. Matériel: Polystyrène.

🇵🇹 Porta-catálogos simples para usar sob a mesa e numa parede. Material: Poliestireno.

🇪🇸 Portacatálogos simple, para su uso en sobremesa o en pared. Material: Poliestireno.

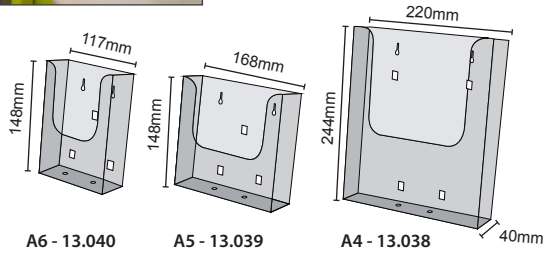
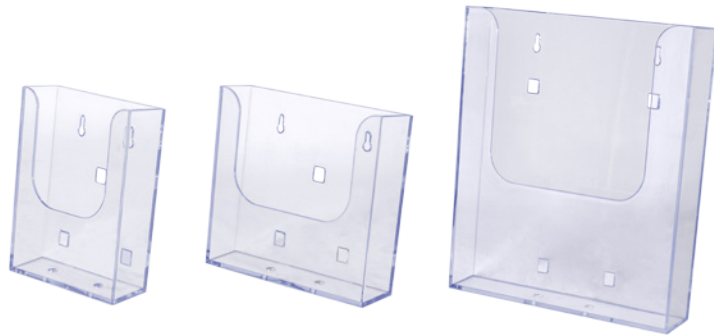
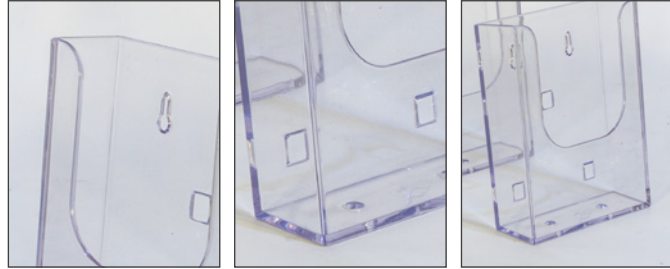

13.038	A4	x10	
13.039	A5	x10	
13.040	A6	x10	

Wire Hanger

🇩🇪 Metall-Regal Halterung. Enthält doppelseitiges Klebeband.

🇬🇧 Metal shelf support. Includes double-sided adhesive.

🇫🇷 Support métallique pour porte brochure. Adhésifs double face inclus.

🇵🇹 Gancho de arame para a colocação de porta folhetos. Fácil e simples de usar. Inclui adesivo.

🇪🇸 Soporte metálico para balda. Incluye adhesivo doble cara.

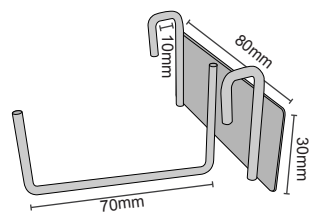

*Acryl-Displays nicht enthalten.
Acrylic leaflet not included.
Acrylique non inclus.
Acrílico não incluído.
Acrílico no incluido.



13.406	Ø 3mm	x10	
--------	-------	-----	--

WALL MOUNTING DISPENSER

Single Wall Mounting or Desk Dispenser

Prospekthalter aus Kunststoff mit Saugnapfhalterung für Glasscheiben, Schaufenster etc. Polystyrol-Material.

Single Wall Mounting or Desk Dispenser with 2 screw holes for wall mounting or using onto the desktop. Made of polystyrene.

Porte catalogue disposant d'un socle arriere pliant pour l'utiliser sur une table, possibilité de le fixer au mur. Matériel: Polystyrène.

Porta-catálogos com apoio traseiro desmontável para usar sob a mesa ou na parede. Material: Poliestireno.

Portacatálogos con peana trasera desmontable, para su uso en sobremesa o en pared. Fabricados en poliestireno.

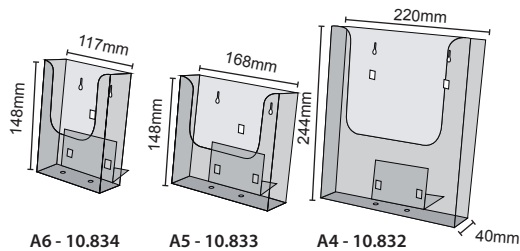
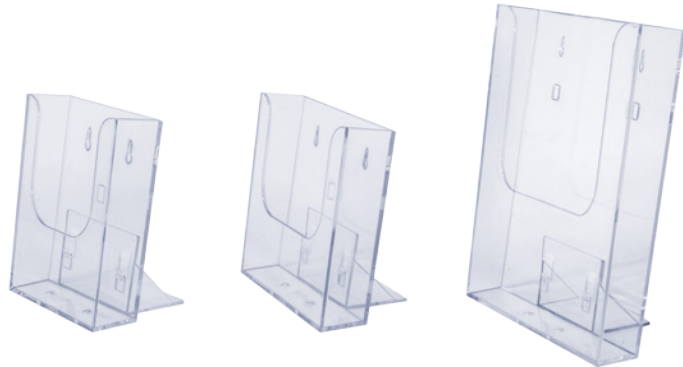
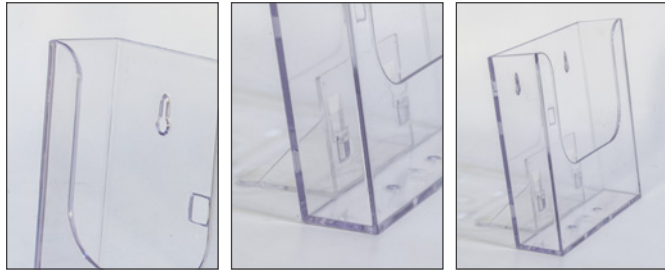

10.832	A4	x10	
10.833	A5	x10	
10.834	A6	x10	

Wall Mounted Dispenser with Suction

Prospekthalter aus Kunststoff mit Saugnapfhalterung für Glasscheiben, Schaufenster etc. Format in DIN A4 (4 Saugnäpfe), A5 und A6 (3 Saugnäpfe). Polystyrol-Material.

Single wall mounting dispenser with suction cup. Colour: transparent. Sizes A4 (4 suction cups), A5 and A6 (3 suction cups). Material: Polystyrene.

Porte catalogue comprenant des ventouses, permettant de l'accrocher aux vitres, vitrines, etc. Fabriqué en polystyrène. Disponible en A4 (4 ventouses), en A5 et A6 (3 ventouses). Matériel: Polystyrène.

Porta-catálogos com ventosas para usar em vidros, montras, escaparates, etc. Fabricados em poliestireno. Tamanhos A4 (4 ventosas), A5 e A6 (3 ventosas). Material: Poliestireno.

Portacatálogos con ventosas, para su uso en cristales, escaparates, etc. Tamaños A4 (4 ventosas), A5 y A6 (3 ventosas). Material: Poliestireno.

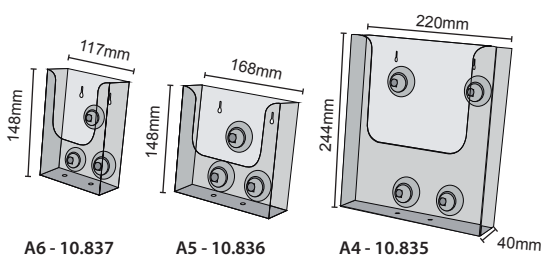
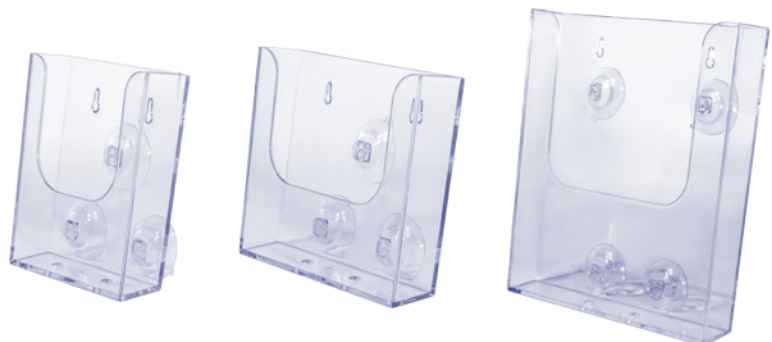





10.835	A4	x10	
10.836	A5	x10	
10.837	A6	x10	

LITERATURE HOLDER

7

Literature Holder

-  Prospekthalter aus Kunststoff für Tisch oder Wand. Polystyrol-Material.
-  Literature holder in different formats for desktop use or wall. Material: Polystyrene.
-  Porte-brochures à poser ou à fixer au mur. Matériel: Polystyrène.
-  Porta-catálogos para usar sobre mesas o na parede. Material: Poliestireno.
-  Portacatálogos de distintos formatos para uso en sobremesa o pared. Material: Poliestireno.

Literature Holder 1/3 A4

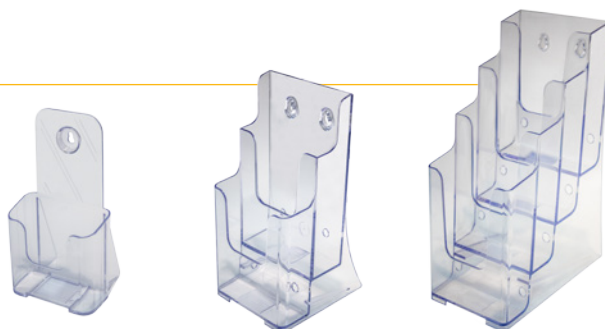
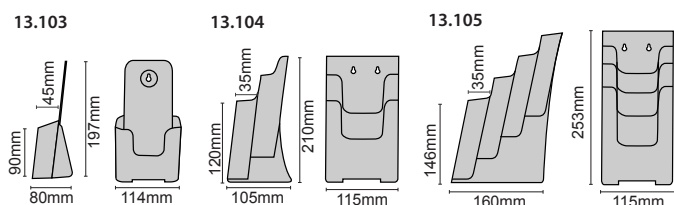
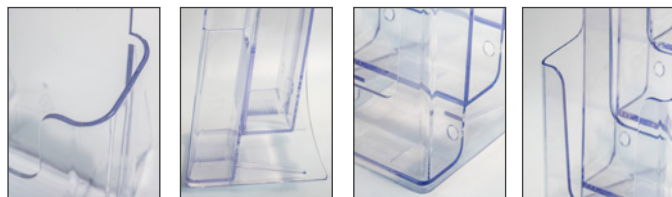

13.103	1x1/3 A4	x6	
13.104	2x1/3 A4	x4	
13.105	4x1/3 A4	x2	

Literature holder A5

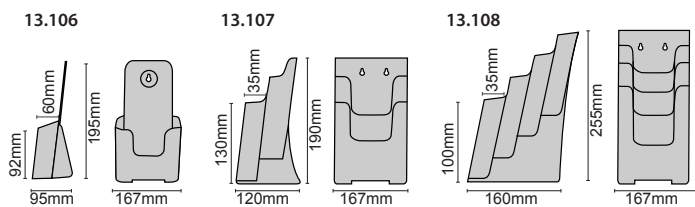
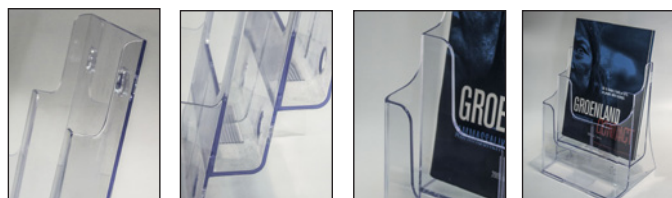



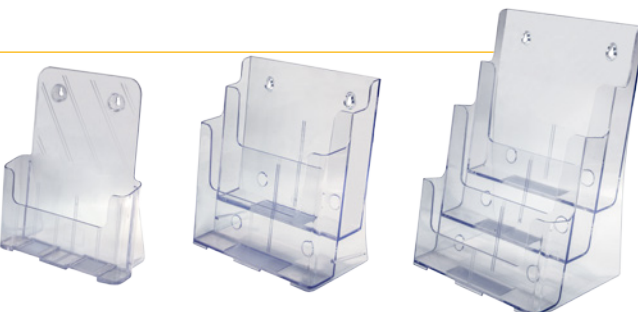
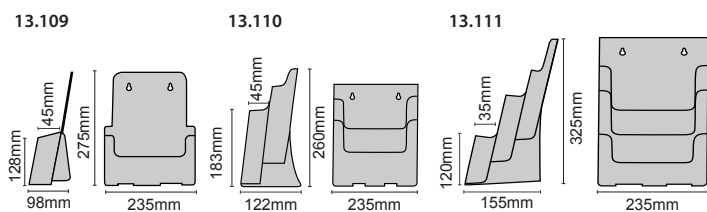
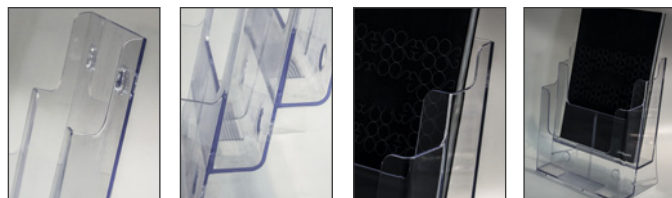

13.106	1xA5	x4	
13.107	2xA5	x4	
13.108	4xA5	x2	

Literature Holder A4



13.109	1xA4	x4	
13.110	2xA4	x2	
13.111	3xA4	x2	

Acrylic Narrow 2 Steps Stand



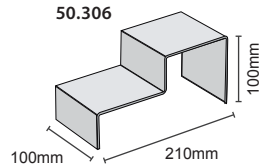
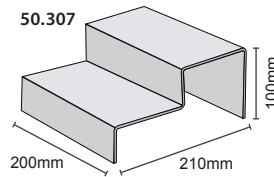

-  Acryl Podium 2 Stufen. Material: Acryl.
-  Acrylic narrow 2 steps stand. Material: Acrylic.
-  Présentoir en 2 niveaux. Fabriqué en acrylique transparent.
-  Acrílico estreito com dois patamares.
-  Podium acrílico de 2 peldaños. Material: Acrílico.



50.306 100x100x210mm 3mm x5 

50.307 200x100x210mm 3mm x5 

Acrylic Narrow 3 Steps Stand



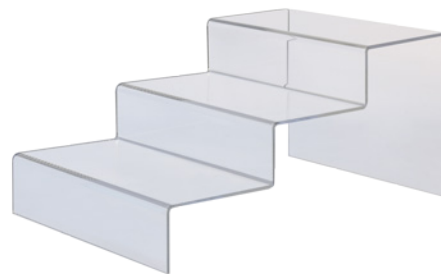
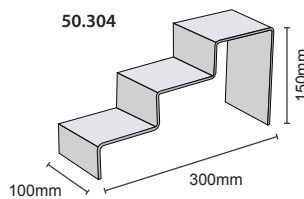
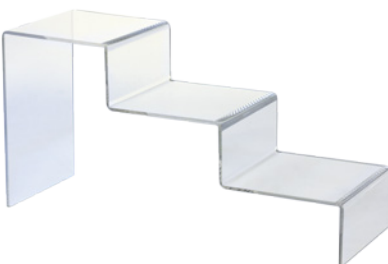
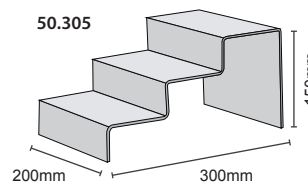

-  Acryl Podium 3 Stufen. Material: Acryl.
-  Acrylic narrow 3 steps stand. Material: Acrylic.
-  Présentoir en 3 niveaux. Fabriqué en acrylique transparent.
-  Acrílico estreito com três patamares.
-  Podium acrílico de 3 peldaños. Material: Acrílico.



50.304 100x150x300mm 3mm x5 

50.305 200x150x300mm 3mm x5 

Acrylic U-Shaped Stand

-  Set von 3 oder 4 U-förmigen Acryl-Podien. Material: Acryl.
-  Set of 3 or 4 U-shaped acrylic stand. Material: Acrylic.
-  Set de 3 ou 4 présentoirs en forme d'U. Fabriqué en acrylique transparent.
-  Conjunto de 3 ou 4 acrílicos.
-  Conjunto de 3 o 4 podiums acrílicos en forma de "U".

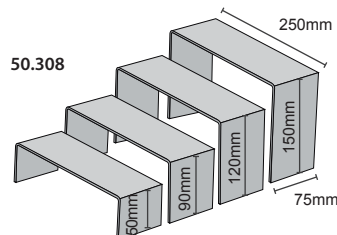
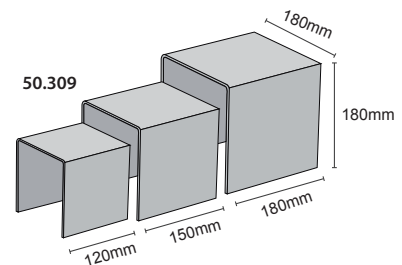

50.308 250x150x75mm 3mm Set of 4

50.309 180x180x180mm 3mm Set of 3

ACRYLIC STAND

7

Acrylic Narrow Podium

Acryl Podium. Material: Acryl.

Acrylic Narrow podium. Material: Acrylic.

Présentoir Podium fabrique en acrylique transparent.

Acrílico em forma de pódio.

Podium acrílico. Material: Acrílico.

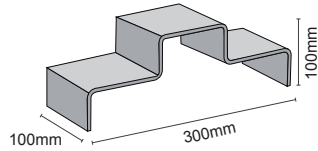

50.303 100x100x300mm 3mm x5

Acrylic Easel

Acryl Staffeeli. Material: Acryl.

Acrylic easel.

Présentoirs en acrylique transparent.

Cavalete de acrílico.

Display acrílico.

50.300	200x50x100mm	2mm	x5	
50.301	100x60mm	2mm	x5	
50.302	140x40x140mm	2mm	x5	
50.322	300x100x150mm	2mm	x5	

50.300

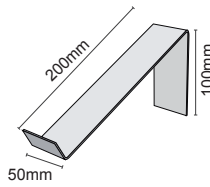

50.301

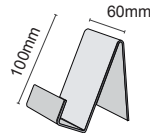

50.302

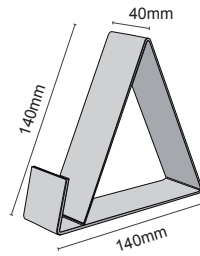

50.322

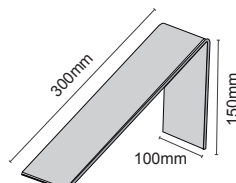

Acrylic Business Card Holders

Acryl-Visitenkartenhalter. Material: Acryl.

Acrylic business card holders. Material: Acrylic.

Présentoir acrylique pour cartes de visite.

Suporte para cartão-de-visita.

Expositor acrílico para tarjetas de visita. Material: Acrílico.

50.319	50x40mm	2mm	x10	
50.320	105x75mm	2mm	x10	
50.321	60x45x40mm	2mm	x10	

50.320



50.319

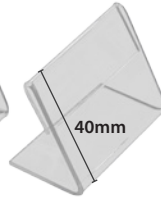

50.321

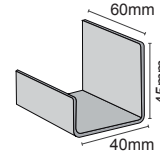

Metal Business Card Holder



Metall Visitenkartenhalter. Metall pulverbeschichtet.

Metal business card holders. Material: Powder coated metal.

Présentoir métallique pour cartes de visite.



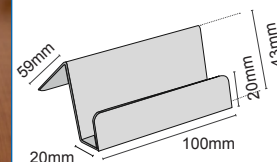

Expositor em metal para cartões-de-visita.

Expositor metálico para tarjetas de visita.



13.413 1mm x10





PVC Tent Display





-  PVC-Display. Farbe: Transparent.
-  PVC Tent Display. Colour: Transparent.
-  Porte visuel en PVC transparent.
-  Suporte em PVC transparente.
-  Portagr fica en PVC. Color: Transparente.







PORTRAIT

LANDSCAPE

13.415P	A6	0.4mm	x50 	
13.416P	A7	0.4mm	x50 	
13.417P	A8	0.4mm	x50 	
13.418P	A9	0.4mm	x50 	
13.419P	A10	0.4mm	x50 	

13.415L	A6	0.4mm	x50 	
13.416L	A7	0.4mm	x50 	
13.417L	A8	0.4mm	x50 	
13.418L	A9	0.4mm	x50 	
13.419L	A10	0.4mm	x50 	





PVC "L" Display

-  PVC-"L"-Display. Farbe: Transparent.
-  PVC "L" Display. Colour: Transparent.
-  Porte visuel en "L", fabriqu  en PVC transparent.
-  Suporte em PVC transparente com forma de "L".
-  Portagr fica "L" en PVC. Color: Transparente.



PORTRAIT

LANDSCAPE

13.356P	A6	0.4mm	x50 	
13.357P	A7	0.4mm	x50 	
13.358P	A8	0.4mm	x50 	
13.359P	A9	0.4mm	x50 	
13.360P	A10	0.4mm	x50 	

13.356L	A6	0.4mm	x50 	
13.357L	A7	0.4mm	x50 	
13.358L	A8	0.4mm	x50 	
13.359L	A9	0.4mm	x50 	
13.360L	A10	0.4mm	x50 	

Desk Acrylic Sign

- Schreibtisch-Acrylschild. Farbe: Transparent. Material: Acryl.
- Desk acrylic sign for table top. Colour: transparent. Material: Acrylic.
- Porte affiche de bureau, fabriqué en acrylique transparent.
- Suporte em acrílico transparente.
- Portagráfica de sobremesa. Color: Transparente. Material: Acrílico.



LANDSCAPE

13.407	298x103x53mm	2mm	x10		
13.408	211x53x30mm	2mm	x20		
13.409	149x34x56mm	2mm	x20		

Desk PVC Sign

- Schreibtisch-PVC Schild. Farbe: Transparent. Material: PVC.
- Desk PVC sign for table top. Material: PVC.
- Porte affiche de bureau, fabriqué en PVC.
- Suporte em PVC transparente.
- Portagráfica de sobremesa. Color: Transparente. Material: PVC.

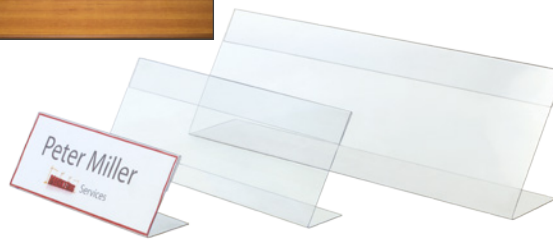

LANDSCAPE

13.410	298x103x53mm	0.5mm	x20		
13.411	211x53x30mm	0.5mm	x20		
13.412	149x34x56mm	0.5mm	x20		

PVC Business Card Holder

- PVC Visitenkartenhalter für Regale, Klebestreifen haften auf einer Seite. Farbe: Transparent.
- PVC business card holder. for adhering to shelves, adhesive strip on one side. Colour: Transparent.
- Support pour cartes de visite, avec adhésif. Fabriqué en PVC. Facile à monter.
- Suporte para cartões de visita em PVC transparente para colocar em prateleiras. Adesivo em um dos lados.
- Dispensador con cinta adhesiva en la solapa. Fácil montaje. PVC.

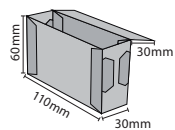
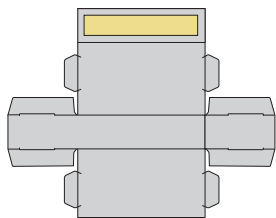

13.431	110x60mm	0.4mm	x30		
--------	----------	-------	-----	--	--

Calendar Support

- Kalender-Unterstützung. Einfach zu montieren. PVC.
- Calendar support. Easy to assemble. PVC.
- Support pour calendrier portrait. Facile à monter. Fabriqué en PVC transparent.
- Suporte em PVC para colocar calendários. Fácil de montar.
- Soporte para calendarios. Fácil montaje. PVC

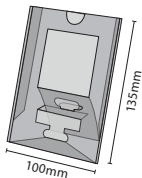

13.432	100x135mm	0.4mm	x30		
--------	-----------	-------	-----	--	--

PVC "Curve" Poster Display

PVC "Curve"-Display. Einfach zu montieren. Einer oder zwei Seiten.

PVC "Curve" poster display. Easy assembly. One or double-sided.

Support incurvé pour poster. Simple et double face. Fabriqué en PVC.

Expositor em PVC curvo para colocação de um cartaz. Fácil de montar. Simple ou dupla face.

Portagráfica "Curva". Fácil montaje. Una o dos caras. PVC.

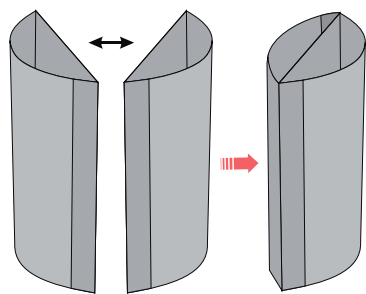
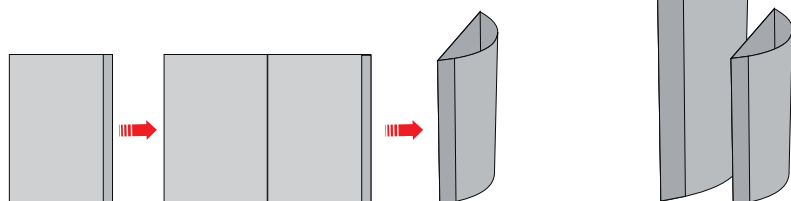

PORTRAIT

13.420	A3	0.4mm	x10	<input type="text"/>
13.421	A4	0.4mm	x10	<input type="text"/>

PVC Poster Display

PVC-Plakat-Display. Farbe: Transparent.

PVC Poster Display. Supplied in plain, easy assembly. PVC.

Support triangulaire pour poster. Fabriqué en PVC.

Expositor triangular em PVC transparente. Distribuído plano.

Portagráfica "Triangular". Se suministra en plano, fácil montaje. PVC.



PORTRAIT

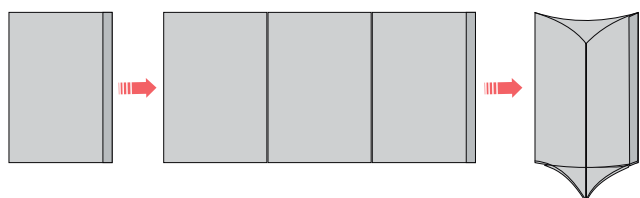

13.422	A4	0.4mm	x10	<input type="text"/>
13.423	A5	0.4mm	x10	<input type="text"/>
13.424	A6	0.4mm	x10	<input type="text"/>

PVC LEAFLET DISPENSER

7

Leaflet Dispenser "T"

🇩🇪 Doppelseitiger Werbeaufsteller aus PVC, für höhere Standsicherheit Fuß magnetisch. Material: PVC.

🇬🇧 Double-sided PVC leaflet dispenser, with magnet on both sides of the base for greater stability. Material: PVC.

🇫🇷 Porte visuels en PVC de double face, la base dispose de 2 aimants pour une meilleure stabilité. Matériel: PVC.

🇵🇹 Porta-impressões PVC de dupla face com ímã em ambos os lados da base para uma maior estabilidade. Material: PVC.

🇪🇸 Portagráficas PVC a doble cara con imán a ambos lados de la base para mayor estabilidad. Material: PVC.

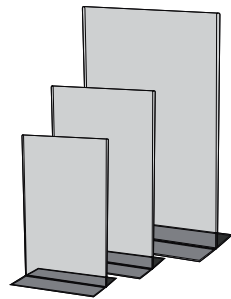

MAGNETIC

13.046	A4	0.5mm	x10	
13.047	A5	0.4mm	x10	
13.048	A6	0.4mm	x10	

Leaflet Dispenser "L"

🇩🇪 Werbeaufsteller aus PVC. Zum Stellen oder Hängen, da Fuß beidseitig magnetisch. Material: PVC.

🇬🇧 PVC leaflet dispenser, with double magnet to be used on two positions. Material: PVC.

🇫🇷 Porte visuel en PVC comprenant un double aimant pour une double utilisation. Matériel: PVC.

🇵🇹 Porta-impressões em PVC com ímã duplo para poder ser usado em duas posições. Material: PVC.

🇪🇸 Portagráficas PVC con imán doble para su uso en dos posiciones. Material: PVC.

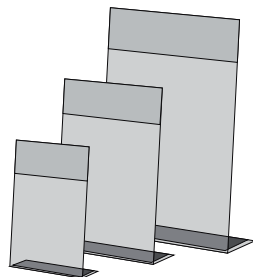

MAGNETIC

13.049	A4	0.5mm	x10	
13.050	A5	0.4mm	x10	
13.051	A6	0.4mm	x10	



PVC LEAFLET DISPENSER

Leaflet Dispenser

Transparenter Prospekthalter PVC zum Schrauben oder Kleben.

Brochure Holder made of transparent PVC with adhesive strip and holes. Supplied in flat, embossed. Easy to assemble.

Porte brochures fabriqué en PVC transparent, comprenant sur la partie haute un adhésif et deux trous. Montage facile.

Porta-folhetos realizados em PVC transparente. Com adesivos e furos. Distribui-se em folha plana. Montagem fácil.

Portafolletos realizados en PVC transparente con adhesivo y agujeros. Se suministran en plano, troquelados. Fácil montaje.

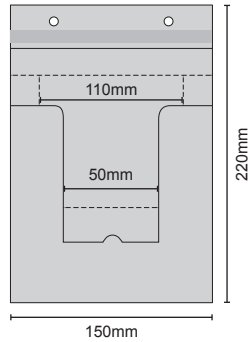

PORTRAIT

13.060 A6 150x220mm 0.5mm x30

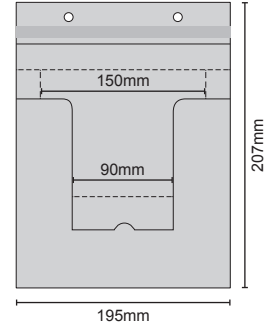
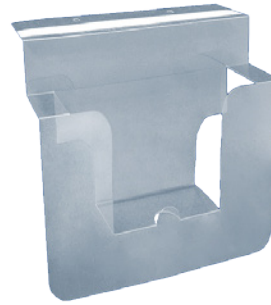

LANDSCAPE

13.061 A6 195x207mm 0.5mm x30

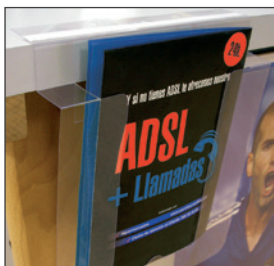
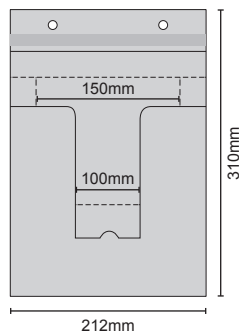
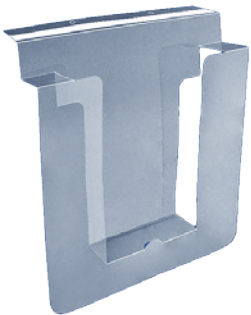

PORTRAIT

13.062 A5 212x310mm 0.5mm x30

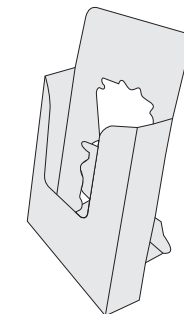
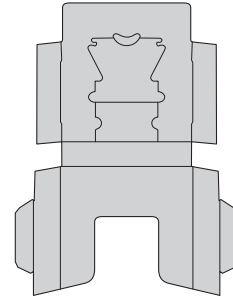

PORTRAIT

13.063 A6 106x140mm 0.6mm x30

PVC LEAFLET DISPENSER

7

PVC Leaflet Dispenser



🇩🇪 Prospekthalter für Regale. Farbe: weiß oder transparent.
Material: PVC.

🇬🇧 Brochure Holder for desktop. Supplied in flat, embossed.
Available in white or transparent. Easy to assemble. PVC.

🇫🇷 Porte brochures en PVC à poser sur table. Disponible en blanc ou transparent.

🇵🇹 Porta folhetos em PVC transparente ou branco.

🇪🇸 Portafolletos para sobremesa. Se suministran en plano, troquelados. Disponible en blanco o transparente. Fácil montaje. PVC.



13.297	A4	0.7mm	x10	
13.298	A5	0.7mm	x10	
13.299	1/3 A4	0.7mm	x10	

13.377	A4	0.7mm	x10	
13.378	A5	0.7mm	x10	
13.379	1/3 A4	0.7mm	x10	

Literature Holder for Countertop

🇩🇪 Dreiseitiger, drehbarer Prospekthalter aus Kunststoff, in den Farben Schwarz oder Weiß. Polystyrol-Material.

🇬🇧 Rotating literature holder. The three-sided unit has transparent pockets for easy viewing. Colours: black or white. Material: Polystyrene.

🇫🇷 Porte-brochures giratoire à 3 faces. Coloris: Blanc et noir. Matériel: Polystyrène.

🇵🇹 Porta-catálogos giratório com 3 faces. Cores disponíveis: branco ou preto. Material: Poliestireno.

🇪🇸 Portacatálogos giratorio tres caras. Colores: Blanco o Negro. Material: Poliestireno.

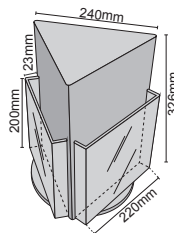

13.115	<input type="checkbox"/>	A4	x1	
13.116	<input checked="" type="checkbox"/>	A4	x1	

Revolving Display

🇩🇪 Drehkranz zur Präsentation von Grafiken. Kunststoff Material.

🇬🇧 Revolving acrylic display. Ideal for the realization of displays. Material: Plastic.

🇫🇷 Support giratoire en acrylique. Idéal pour la création d'un display. Matériel: Plastique.

🇵🇹 Suporte em acrílico giratório. Ideal para a realização de displays. Material: Plástico.

🇪🇸 Soporte acrílico giratorio. Ideal para la realización de displays. Material: Plástico.

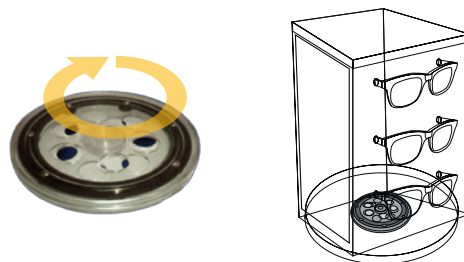

13.072	Ø 140mm	x2	
--------	---------	----	--

SHOWCARD POCKET

Adhesive or Magnetic Showcard

 Grafiktasche mit Magnet- oder Klebeband an Ober- und Unterseite. Material: PVC.

 Overhead magnet or adhesive on the top and bottom back part for increased clamping. Material: PVC.

 Porte affiches comprenant soit un aimant ou un adhésif à l'arrière sur la partie haute et basse permettant une meilleure fixation. Matériel: PVC.

 Filmina com íman ou adesivo superior ou inferior na parte posterior para uma maior fixação. Material: PVC.

 Filmina con imán o adhesivo superior e inferior en la parte posterior para mayor sujeción. Material: PVC.

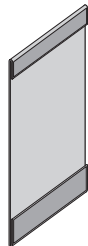

MAGNETIC

ADHESIVE

13.425	A1	0.4mm	x10 	<input type="text"/>	
13.426	A2	0.4mm	x10 	<input type="text"/>	
13.052	A3	0.4mm	x10 	<input type="text"/>	
13.053	A4	0.4mm	x10 	<input type="text"/>	
13.054	A5	0.4mm	x20 	<input type="text"/>	
13.055	A6	0.4mm	x20 	<input type="text"/>	
13.427	A7	0.4mm	x30 	<input type="text"/>	

13.428	A1	0.4mm	x10 	<input type="text"/>	
13.429	A2	0.4mm	x10 	<input type="text"/>	
13.064	A3	0.4mm	x10 	<input type="text"/>	
13.065	A4	0.4mm	x10 	<input type="text"/>	
13.066	A5	0.4mm	x20 	<input type="text"/>	
13.067	A6	0.4mm	x20 	<input type="text"/>	
13.430	A7	0.4mm	x30 	<input type="text"/>	

LEAFLET DISPENSER

7

Wall Mounted Leaflet Dispenser

Prospekthalter aus Kunststoff zur Wandbefestigung. Format in DIN A4 und DIN A5. Polystyrol-Material.

Wall mounted Leaflet Dispenser with several compartments. Made of polystyrene. For A4 and A5 catalogs. Supplied in individual boxes.

Porte catalogues à fixer au mur comprenant plusieurs compartiments. Fabriqué en polystyrène. Possibilité de placer des catalogue A4 et A5. Matériel: Polystyrène.

Porta-catálogos para colocar na parede com várias divisórias. Fabricados em poliestireno. Tamanhos para catálogo A4 e A5. Distribuem-se em caixas individuais. Material: Poliestireno.

Portacatálogos para pared con varios cajetines. Fabricados en poliestireno. Tamaños para catálogos A4 y A5. Se suministran en cajas individuales. Poliestireno.

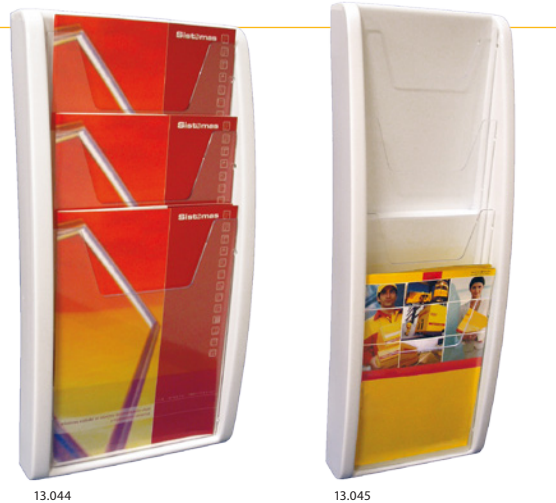

13.044

13.045

13.044	3x A4	x1	
13.045	4x A5	x1	



Wall Pocket Landscape or Portrait

Prospekthalter für die Wand. Modelle für horizontale oder vertikale Nutzung. Polystyrol-Material.

Document wall support. Horizontal or Vertical. Polystyrene.

Porte documents à fixer au mur. Disponible en Horizontal ou vertical. Matériel: Polystyrène.

Suporte de documentos para parede. Horizontal ou Vertical. Tamanho A4. Material: Poliestireno.

Soporte de documentos a pared. Horizontal o Vertical. Poliestireno.

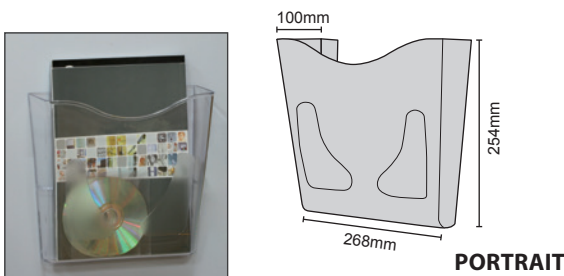

PORTRAIT

	QTY	N.W(kg)	G.W(kg)	C.B.M.	Size(mm)
Uni.	1	0.32	0.52	0.008	270x270x115

13.126 **A4** **x1** **4.50 €**

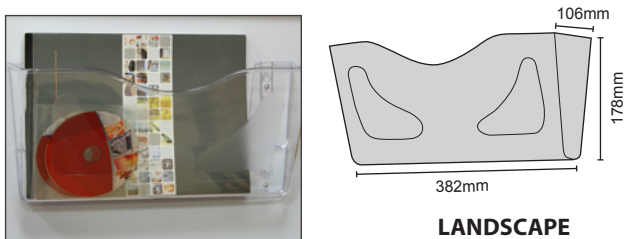

LANDSCAPE

	QTY	N.W(kg)	G.W(kg)	C.B.M.	Size(mm)
Uni.	1	0.30	0.50	0.009	405x200x115

13.127 **A4** **x1**

Outdoor Literature Box

Briefkasten bzw. Prospektbox mit integrierter Grafikfläche, für Outdoor Bereich. Polystyrol-Material.

Outdoor Mailbox or Document holder. Possibility of placing a graphic. Break-resistant and weatherproof. Material: Polystyrene.

Boîte aux lettres ou porte documents pour l'extérieur. Possibilité d'insérer un visuel. Matériel: Polystyrène.

Caixa de correio o porta documentos para exterior. Posibilidade de colocar impressão. Material: Poliestireno.

Buzón o portadocumentos para exterior. Posibilidad de colocar una gráfica. Material: Poliestireno.

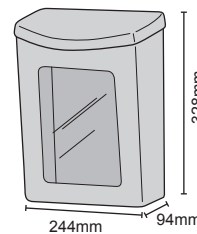

PORTRAIT

	QTY	N.W(kg)	G.W(kg)	C.B.M.	Size(mm)
Uni.	1	0.6	0.8	0.013	270x350x140

13.125 **x1**

Menubook

Präsentationsständer für Tisch oder Boden. Inklusive 10 Kunststofftaschen DIN A4. Material: Stahl, Gummi und Kunststoff.

Menubook for desktop or floor using. Includes 10 plastic envelopes A4 size. Material: Steel, rubber and plastic.

Menubook à poser sur une table ou au sol. Inclus 10 pochettes plastiques de format A4. Fabriqué en acier, caoutchouc et plastique.

Menubook de mesa ou chão. Inclui 10 micas em plástico tamanho A4. Material: Aço, borracha e plástico.

Menubook de sobremesa o suelo. Incluye 10 sobres plásticos tamaño A4. Material: Acero, caucho y plástico.



13.123

	QTY	N.W(kg)	G.W(kg)	C.B.M.	Size(mm)
Uni.	1	5.2	5.4	0.018	345x155x345
13.123	A4 "Black"			x1	



13.122

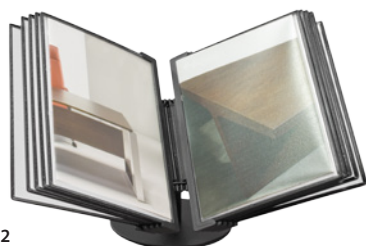

	QTY	N.W(kg)	G.W(kg)	C.B.M.	Size(mm)
Uni.	1	1.9	2.15	0.012	340x100x360
13.122	A4 "Black"			x1	

Wall Mounting Leaflet Dispenser

Prospekthalter zum Befestigen an der Wand. Polystyrol-Material.

Wall Mounting Leaflet Dispenser. Material: Polystyrene.

Porte-brochures à fixer au mur. Matériel: Polystyrène.

Porta-catálogos para usar na parede. Material: Poliestireno.

Portacatálogos para uso de pared. Material: Poliestireno.

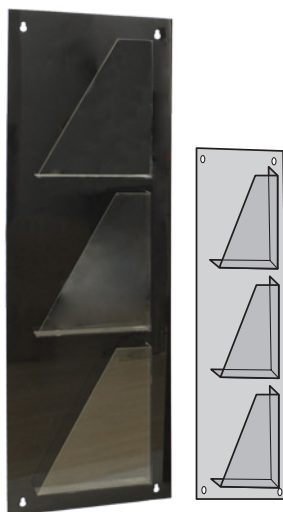

13.114



13.112

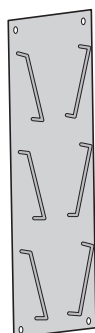

13.113



13.112	A4 "Line"	320x1009mm	x1	
13.113	A4 "Oval"	320x1009mm	x1	
13.114	A4 "Flash"	320x1009mm	x1	

WIRE LEAFLET DISPENSER

7

Chromed Leaflet Dispenser

🇩🇪 Prospekthalter aus verchromtem Stahl für Tisch oder Wand.
Material: verchromter Draht, Gummi.

🇬🇧 Chromed metal leaflet dispenser. Rubber feet protect the countertop's surfaces. Material: Chromed wire, rubber.

🇫🇷 Porte Brochures fabriqué en métal chromé à poser ou à fixer au mur. Protections en caoutchouc.

🇵🇹 Porta-folhetos em metálico cromado para colocar sobre mesas ou na parede.

🇪🇸 Portafolletos metálicos de sobremesa o a pared cromados. Material: Metal y piezas de goma.



	QTY	N.W(kg)	G.W(kg)	C.B.M.	Size(mm)
Uni.	1	0.35	0.55	0.010	270x150x270
13.117	1x A4			x1 📦	

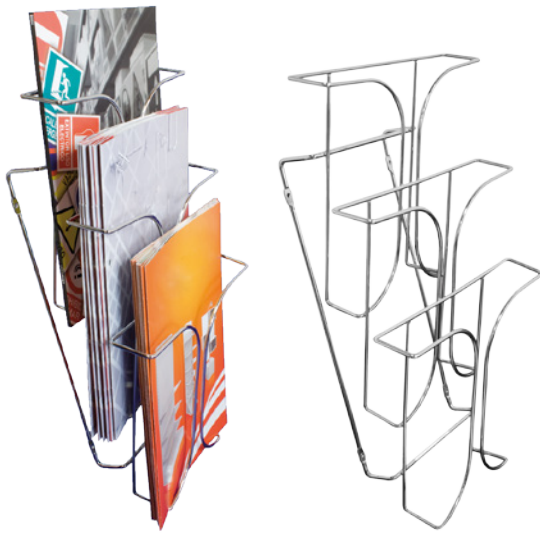

	QTY	N.W(kg)	G.W(kg)	C.B.M.	Size(mm)
Uni.	1	0.65	0.85	0.027	270x230x450
13.118	3x A4			x1 📦	



	QTY	N.W(kg)	G.W(kg)	C.B.M.	Size(mm)
Uni.	1	0.60	0.80	0.015	270x200x295
13.120	4x 1/3 A4			x1 📦	



	QTY	N.W(kg)	G.W(kg)	C.B.M.	Size(mm)
Uni.	1	0.70	0.90	0.029	270x230x470
13.119	3x A4			x1 📦	



	QTY	N.W(kg)	G.W(kg)	C.B.M.	Size(mm)
Uni.	1	0.25	0.45	0.004	135x140x220
13.121	1/3 A4			x1 📦	

Acrylic Hinge

Acryl-Scharnier in verschiedenen Größen erhältlich. Farbe: Transparent. Material: Acryl.

Acrylic hinge available in different sizes. Colour: Transparent.

Charnière en acrylique transparent. Plusieurs tailles disponibles.

Bisagra em cor transparente. Disponível em vários tamanhos.

Bisagras acrílicas, disponibles en diferentes medidas.

200mm - 10.943



100mm - 10.944



65mm - 10.945

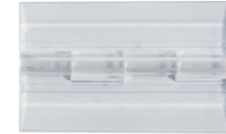

45mm - 10.946



30mm - 10.947



25mm - 10.948

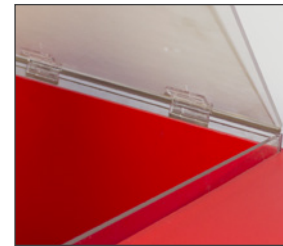
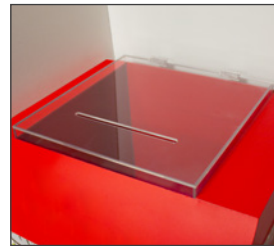
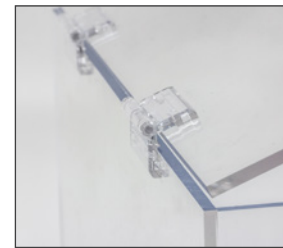
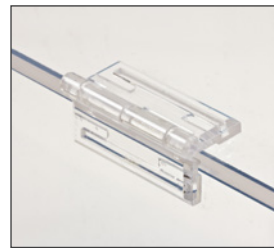

Acrylic Hinge 200mm

10.943 200mm x20

Acrylic Hinge 100mm

10.944 100mm x20

Acrylic Hinge 65mm

10.945 65mm x20

Acrylic Hinge 45mm

10.946 45mm x20

Acrylic Hinge 30mm

10.947 30mm x20

Acrylic Hinge 25mm

10.948 25mm x20

Acrylic Hanger 3 Pieces

Acryl Aufhänger, 3 Stück. Farbe: transparent. Material: Acryl.

Three pieces acrylic hanger. Colour: transparent.

Support pour suspension en 3 pièces fabriqué en acrylique transparent.

Suspensão de acrílico transparente composta por três peças.

Colgador de tres piezas en acrílico.

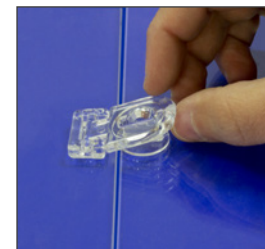

10.949 x20

Acrylic Hanger

Acryl Aufhänger. Farbe: transparent. Material: Acryl.

Acrylic hanger. Colour: transparent.

Support pour suspension en acrylique transparent.

Suspensão de acrílico transparente.

Colgador acrílico. Color: transparente.



10.950 22x25mm x20



RAL-COLOUR CARD

RAL 1000	RAL 1013	RAL 1027	RAL 2008	RAL 3005	RAL 3018
RAL 1001	RAL 1014	RAL 1028	RAL 2009	RAL 3007	RAL 3020
RAL 1002	RAL 1015	RAL 1032	RAL 2010	RAL 3009	RAL 3022
RAL 1003	RAL 1017	RAL 1033	RAL 2011	RAL 3011	RAL 3027
RAL 1004	RAL 1018	RAL 1034	RAL 2012	RAL 3012	RAL 3031
RAL 1005	RAL 1019	RAL 2000	RAL 3000	RAL 3013	RAL 4001
RAL 1006	RAL 1020	RAL 2001	RAL 3001	RAL 3014	RAL 4002
RAL 1007	RAL 1021	RAL 2002	RAL 3002	RAL 3015	RAL 4004
RAL 1011	RAL 1023	RAL 2003	RAL 3003	RAL 3016	RAL 4005
RAL 1012	RAL 1024	RAL 2004	RAL 3004	RAL 3017	RAL 4006
RAL 4007	RAL 5008	RAL 5019	RAL 6005	RAL 6015	RAL 6026
RAL 4008	RAL 5009	RAL 5020	RAL 6006	RAL 6016	RAL 6027
RAL 4009	RAL 5010	RAL 5021	RAL 6007	RAL 6017	RAL 6028
RAL 5000	RAL 5011	RAL 5022	RAL 6008	RAL 6018	RAL 6029
RAL 5001	RAL 5012	RAL 5024	RAL 6009	RAL 6019	RAL 6032
RAL 5002	RAL 5013	RAL 6000	RAL 6010	RAL 6020	RAL 7000
RAL 5003	RAL 5014	RAL 6001	RAL 6011	RAL 6021	RAL 7001
RAL 5004	RAL 5015	RAL 6002	RAL 6012	RAL 6022	RAL 7002
RAL 5005	RAL 5017	RAL 6003	RAL 6013	RAL 6024	RAL 7003
RAL 5007	RAL 5018	RAL 6004	RAL 6014	RAL 6025	RAL 7004
RAL 7005	RAL 7021	RAL 7035	RAL 7046	RAL 8012	RAL 8028
RAL 7006	RAL 7022	RAL 7036	RAL 7047	RAL 8014	RAL 9001
RAL 7008	RAL 7023	RAL 7037	RAL 8000	RAL 8015	RAL 9002
RAL 7009	RAL 7024	RAL 7038	RAL 8001	RAL 8016	RAL 9003
RAL 7010	RAL 7026	RAL 7039	RAL 8002	RAL 8017	RAL 9004
RAL 7011	RAL 7030	RAL 7040	RAL 8003	RAL 8019	RAL 9005
RAL 7012	RAL 7031	RAL 7042	RAL 8004	RAL 8022	RAL 9006
RAL 7013	RAL 7032	RAL 7043	RAL 8007	RAL 8023	RAL 9007
RAL 7015	RAL 7033	RAL 7044	RAL 8008	RAL 8024	RAL 9010
RAL 7016	RAL 7034	RAL 7045	RAL 8011	RAL 8025	RAL 9011

RAL 9016

RAL 9017

RAL 9018

* RAL Colour Chart is only for colour reference.



BARRIER POLE

Barrier Pole	264
Barrier Pole Accessories	268
Plastic Barrier Pole	269
Cones - Accessories	270

BARRIER POLE

8

Barrier Pole with Retractable Tape

 Absperrränder aus Stahl mit automatischem Zuggurt, Absperrlänge 2m. Sicherheitsvorrichtung, damit Gurt nicht aus der Halterung rutschen kann.













 Barrier pole with retractable tape and connection point for 3 tapes. Dome base with 320mm diameter. Steel, plastic parts.

 Poteau séparateur en acier comprenant une sangle extensible de 2m avec dispositif de sécurité et un socle.

 Poste separador com fita retráctil e 3 pontos de ligação. Base arredondada com 320 mm de diâmetro. Aço e plástico.

 Poste separador de acero con cinta extensible retráctil y base entallada, incluye 2 metros de cinta extensible y dispositivo de seguridad para que la cinta no salga del enganche del poste.



- | | | | |
|--------|-----------|---|--|
| 10.335 | Yellow |  |  |
| 10.331 | Orange |  |  |
| 10.336 | Red |  |  |
| 10.330 | Green |  |  |
| 10.421 | Blue |  | |
| 10.904 | Black |  | |
| 10.340 | Black/Red |  |  |
| 10.420 | Gray |  | x2  |

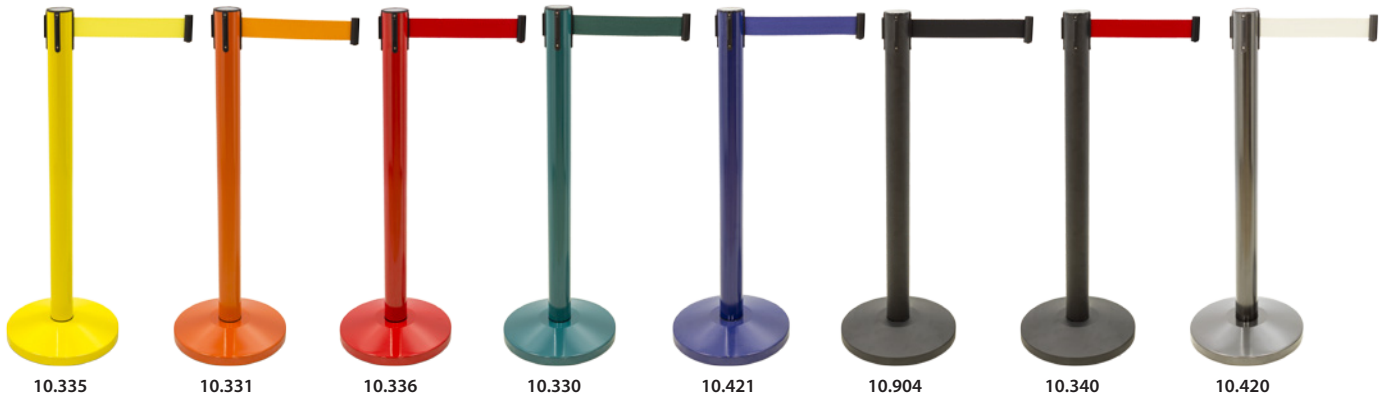
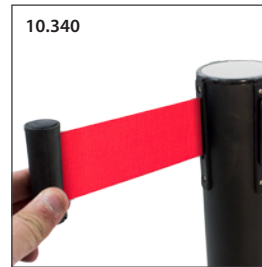

Security lock

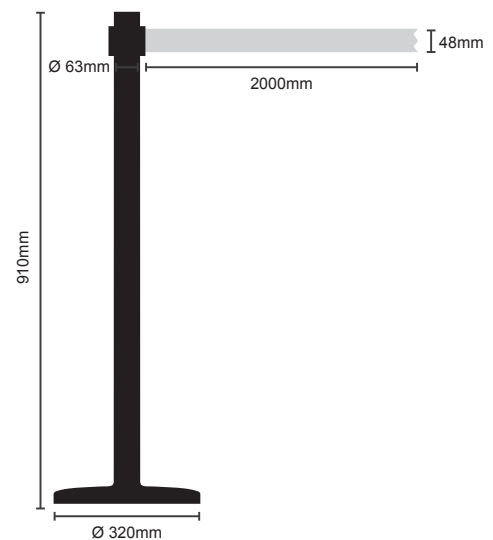
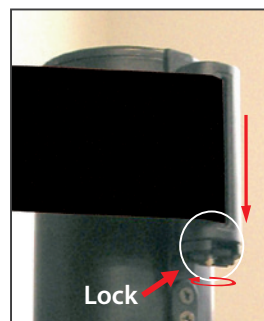



Barrier Pole with Retractable Tape

 Absperrständer aus Stahl mit automatischem Zuggurt, Absperrlänge 2m. Sicherheitsvorrichtung, damit Gurt nicht aus der Halterung rutschen kann.

 Barrier pole with retractable tape and connection point for 3 tapes. Dome base with 320mm diameter. Steel, plastic parts.

 Poteau séparateur en acier comprenant une sangle extensible de 2m avec dispositif de sécurité et un socle.

 Poste separador com fita retráctil e 3 pontos de ligação. Base arredondada com 320mm de diâmetro. Aço e plástico.

 Poste separador de acero con cinta extensible retráctil y base entallada, incluye 2 metros de cinta extensible y dispositivo de seguridad para que la cinta no salga del enganche del poste.

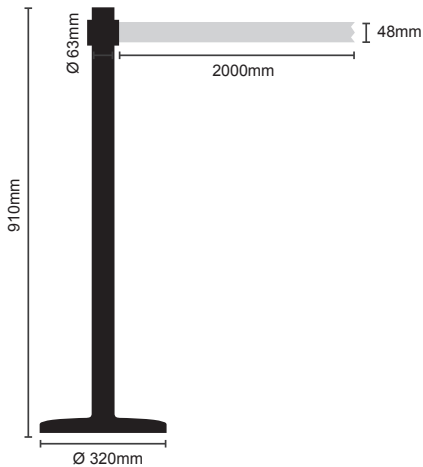



10.903	Silver		x2 	<input type="text"/>
10.905	Gold		x2 	<input type="text"/>

Barrier Pole Double Retractable Tape

 Absperrständer aus Stahl mit doppelter Zuggurt-Vorrichtung. Die verchromten und schwarzen Ständer sind mit schwarzem Zuggurt, blaue Ständer mit blauem Zuggurt.

 Extensible double pole separator tape. Black Tape for black and chrome poles, and blue tape for the blue pole.

 Poteau séparateur comprenant deux sangles extensibles. Poteau chromés ou noirs avec sangles noires. Poteaux bleus avec sangles bleus.

 Poste separador com duas fitas extensíveis.

 Poste separador con doble cinta extensible. Cinta negra en postes cromado y negro, cinta azul en poste de color azul.





10.926		<input type="text"/>
10.927		<input type="text"/>
10.928		<input type="text"/>

**Ø 320x910mm
Tube: Ø 63mm**

Wall Mount Tensorope Support

 Gurtauszug zur Wandbefestigung mit schwarz lackiertem Stahlgehäuse oder verchromt.

 Wall Mount in black lacquered or chromed steel ribbon tape. Includes wall anchor piece.

 Support mural en acier noir laqué ou chromé comprenant une sangle extensible. Pièces de fixation murale incluses.

 Suporte de parede em aço lacado em preto ou cromado com fita extensível. Inclui peça de fixação à parede.

 Soporte de pared en acero lacado negro o cromado con cinta extensible. Incluye pieza de anclaje a pared.







10.918		<input type="text"/>
10.975		<input type="text"/>

Ø 63x130mm



BARRIER POLE

8





Chrome Rope Barrier Queuing System

-  Absperrständer in Chrom-Optik für Kordelsystem. (Kordel nicht inklusive).
-  Post for lace fitted with smooth tube and base. (Cord not included).
-  Poteau avec socle, pour corde. (Corde non incluse).
-  Poste para cordão com tubo liso e base esculpida. (Cordão não incluído).
-  Poste para cordón con tubo liso y base entallada. (Cordón no incluido).





- | | | | | |
|---------------|--------------------------|---------------------------|--|--|
| 10.908 | <input type="checkbox"/> | Ø 320x910mm Tube: Ø 50mm | x2  | |
| 10.910 | <input type="checkbox"/> | Ø 320x1000mm Tube: Ø 50mm | x2  | |

Brass Rope Barrier Queuing System

-  Absperrständer in Chrom-Optik für Kordelsystem. (Kordel nicht inklusive).
-  Post for lace fitted with smooth tube and base. (Cord not included).
-  Poteau avec socle, pour corde. (Corde non incluse).
-  Poste para cordão com tubo liso e base esculpida. (Cordão não incluído).
-  Poste para cordón con tubo liso y base entallada. (Cordón no incluido).





- | | | | | |
|---------------|--------------------------|---------------------------|--|--|
| 10.909 | <input type="checkbox"/> | Ø 320x910mm Tube: Ø 50mm | x2  | |
| 10.911 | <input type="checkbox"/> | Ø 320x1000mm Tube: Ø 50mm | x2  | |

Rope Barrier Queuing System with Frame

 Diskretionsständer mit Rahmen für Kordel-Absperrsystem. Grafikgröße horizontal: 420x320mm. Grafikgröße vertikal: 320x420mm.

 Rope barrier queuing system with frame. Graphic size portrait: 320x420mm. Graphic size landscape: 420x320mm. Material: Steel.

 Poteau avec socle, pour corde. Format du visuel horizontal 420x320. Format du visuel vertical 320x420.

 Poste para cordão com base esculpida e marco. Área de impressão horizontal: 420x320mm. Área de impressão vertical: 320x420mm.

 Postes para cordón con base entallada y marco. Área gráfica horizontal: 420x320mm. Área gráfica vertical: 320x420mm.



- | | | | | |
|---------------|--------------------------|-----------------------|--|--|
| 10.912 | <input type="checkbox"/> | Ø 320x1440mm - Chrome | | |
| 10.913 | <input type="checkbox"/> | Ø 320x1440mm - Brass | | |

- | | | | | |
|---------------|--------------------------|-----------------------|--|--|
| 10.914 | <input type="checkbox"/> | Ø 320x1300mm - Chrome | | |
| 10.915 | <input type="checkbox"/> | Ø 320x1300mm - Brass | | |

BARRIER POLE

Retractable Belt Stanchions with Roller

Absperrständer mit einziehbarem und dehnbarem Gurt. Inklusive Rad zur leichteren Handhabung.

Retractable belt stanchions with roller. Cast iron. Flat base. Available in two colours. Material: Steel, plastic parts.

Poteau séparateur avec sangle extensible. Inclut une roue dans sa partie inférieure pour une manipulation facile.

Poste separador com base plana que possui uma roda. Disponível em duas cores. Material: aço fundido e plástico.

Poste separador con cinta extensible y retráctil. Incluye rueda en su parte inferior para su fácil manejo.

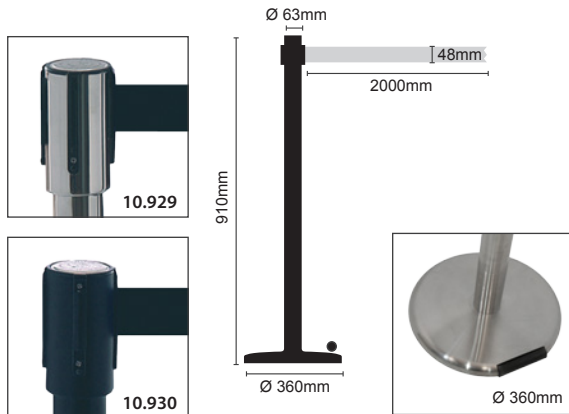

10.929

Silver

10.930

Black



Chrome Bars 1200mm

Chrom-Leiste für Seilabspernung. Stahl.

Chrome Bars for Rope Barrier. Steel.

Barre en acier chromé pour poteaux.

Barras de aço para colocar em postes.

Barra cromada para postes. Acero.



10.990

1200mm Tube: Ø 20mm



Chrome Ring Ø 100mm

Chrom-Ring für Seilabspernung. Stahl.

Chrome Ring for Rope Barrier. Steel.

Anneaux en acier chromé pour poteaux.

Anilha cromada para postes.

Anilla cromada para postes. Acero.



10.991

Ø 100mm

BARRIER POLE ACCESSORIES

8

Bowl and Connector

Kunststoffschütte mit Verbindungsstück für Ständer.

Plastic dispenser for posts.

Distributeur en plastique pour poteaux.

Acessório dispensador.

Accesorio dispensador.



10.931 Ø 200mm

10.932 Ø 300mm

Sign Board for Barrier Pole

Titanium-Rahmen für Absperrständer, aus vergoldetem oder rostfreiem Stahl.

Titanium frame to place tape on poles; available in two finishings stainless steel and gold.

Cadre en titane à fixer sur les poteaux à sangle. Couleur acier ou dorée.

Marco de titânio para colocar nos postes com fita, disponível em aço inoxidável e dourado.

Marco de titanio para colocar en postes con cinta; disponible en dos terminaciones acero inoxidable y dorado.



10.916 380x265mm

10.917 380x265mm

Rope With Hook

Abspermband glatt oder geflochten, Endkappen und Haken vergoldet oder aus rostfreiem Stahl, Länge 1,5m.

Smooth or twisted pair cords 1,5m long with two types of endings for the hooks, stainless steel or gold.

Cordes lisses ou entrelacées de 1,5m de long, avec deux sortes de douilles : chromé ou doré.

Cordões lisos ou entrançados de 1,5m de comprimento com dois tipos de acabamentos para encaixe, em cromado e dourado.

Cordones lisos o trenzados de 1,5m de largo con dos tipos de terminaciones para los enganches, en acero inoxidable o dorado.

Smooth Ropes



10.919 1500mm

10.920 1500mm

10.921 1500mm

10.922 1500mm

Braided Ropes



10.923 1500mm

10.924 1500mm

10.925 1500mm

Lightweight Barrier Post

Absperpfosten aus Kunststoff für Außeneinsatz. Höhe ohne Fuß: 900mm. Ausgenommen Ref.Nr.: 0489004 Höhe: 800mm.

Lightweight barrier post. Height: 900mm. Except item number 0489004 that the height is 800mm. Material: Plastic.

Poteau séparateur pour l'extérieur. Hauteur: 900mm sans la base. Sauf pour le poteau de jardin qui a une hauteur de 800mm.

Postes delimitadores para exterior. Altura 900mm sem base. Excepto o pau de jardim com altura de 800mm.

Poste delimitador para exterior. Altura 900mm sin base. Excepto palo de jardín altura 800mm.

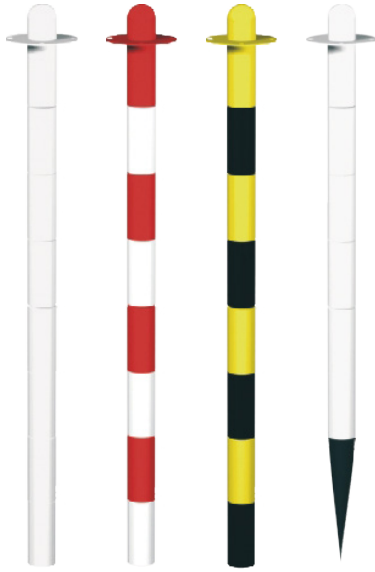

0489001 0489002 0489003 0489004

0489001

0489002

0489003 900mm x16

0489004 800mm x2



Rubber Base - Water Base

Standfüße für Absperpfosten.

Bases for plastic barrier pole.

Base pour poteaux.

Bases para postes.

Bases para postes.

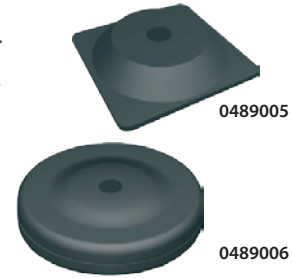

0489005 300x300mm x16

0489006 Ø 300mm x16

Plastic Chain

Kunststoff Gliederkette für Absperpfosten. Verfügbar in verschiedenen Farben, Materialstärken 5mm und 8mm. Länge 25m.

Plastic chain to connect to the posts. Different colors and two thicknesses: 5mm and 8mm. Length 25m.

Chaîne en plastique pour la liaison des poteaux entre eux. Disponible en plusieurs couleurs, épaisseur: 5 et 8mm. Longueur: 25m.

Corrente de plástico para unir aos postes. Diferentes cores e dois tipos de grossura, 5mm e 8mm. Comprimento 25m.

Cadena de plástico para conectar a los postes. Diferentes colores y dos grosos, 5mm y 8mm. Longitud 25m.



0489011

0489012

0489008

0489009

0489010

0489011 5mm 25m x4

0489012 5mm 25m x4

0489008 8mm 25m x4

0489009 8mm 25m x4

0489010 8mm 25m x4

Chain Connectors

Kettenglied zum Verbinden von zwei Ketten.

Chain connector for plastic chain. Material: Plastic.

Connecteur pour l'union des chaînes.

Conector para a união de duas correntes.

Conector para la unión de dos cadenas.



0489015 5mm x25

0489014 8mm x25

Reflective Sign

Reflektierendes rechteckiges Signalschild, mit Haken zum Einhängen.

Reflective rectangle for hanging with hook.

Rectangle réfléchissant comprenant un crochet pour la suspension.

Rectángulo reflector com gancho para pendurar.

Rectángulo reflectante con gancho para colgar.



0489016 140x105mm x10

Cones

Leitkegel.

Cones.

Cônes.

Cones.

Conos.



0489017		300mm	x20		
0489018		300mm	x20		
0489019		300mm	x20		

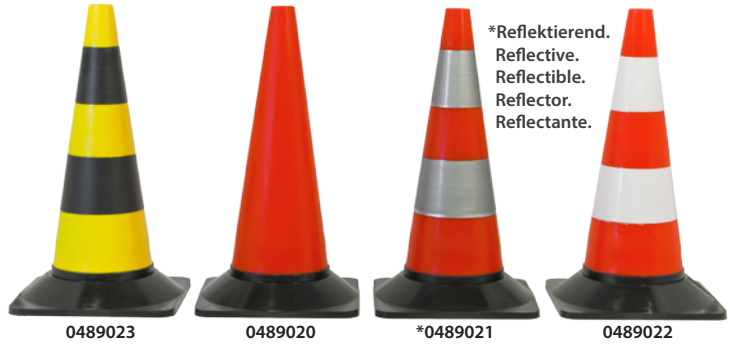

*Reflektierend.
Reflective.
Reflective.
Reflector.
Reflectante.

0489023			500mm	x10		
0489020			500mm	x10		
0489021			500mm	x10		
0489022			500mm	x10		

Cone Tops

Aufsatz für Leitkegel.

Cone Tops. Material: Plastic.

Bouchon pour cône.

Tampa para cone.

Tapón para cono.



0489024				x10		
---------	--	--	--	-----	--	--

Tape Signalling

Absperrband.

Tape signalling.

Bande Balisage.

Fita balizagem.

Cinta de Balizamiento.



0479001			80mm	200m	x5		
---------	--	--	------	------	----	--	--



0479004			80mm	200m	x5		
---------	--	--	------	------	----	--	--

Stop Sign

Doppelseitige Signalschilder aus PVC.

Stop sign. Double face. Material: PVC.

Signalétique en PVC avec impression double face.

Sinalização em PVC. Impressão em ambas as faces.

Paleta Stop, material PVC. Impresa a doble cara.



0080011				x3		
---------	--	--	--	----	--	--

Restrict Access to Parking Spaces

Absperrbügel aus Aluminium für In- und Outdoor Bereich.

Aluminium restrict access to parking whit lock.

Barrière de parking en aluminium pour l'intérieur ou l'extérieur.

Barreira de alumínio para parque.

Guardaparking de aluminio para interior o exterior.



LOCKABLE

0080010			400x720mm			
---------	--	--	-----------	--	--	--



PLV

ShowCard Frames - Support	272
Mini Showcard Frames - Accessories	279
Sign Clip	280
Exhibition System	285
Name Badges	316
Suspension Rope	319
Mobile Kits	320

SHOWCARD FRAMES - SUPPORT

9

ABS Frames

 Hochwertiger und äußerst resistenter ABS Rahmen. Verfügbar in verschiedenen Farben und kann somit individuell auf Grafik abgestimmt werden. Zusätzliche Gestaltungsmöglichkeiten durch das Kombinieren mit anderem Zubehör. Rahmenöffnung an den Stirnseiten.

 Frames constructed of high quality ABS. Available in different colors, and fully adaptable to the image of your visual message. They are also durable and compatible with many accessories, which will make them the most versatile when it comes to show your signage. Opening on the smaller side (short side).

 Cadres en plastique ABS de haute qualité. Disponibles en différentes colories. Résistants et compatibles avec différents accessoires. L'ouverture se fait par le côté le plus petit.

 Marcos fabricados em plástico ABS de diferentes cores. Marcos de grande resistência com uma ranhura para a colocação de impressões.

 Marcos construidos en ABS de alta calidad. Disponibles en diferentes colores, y totalmente adaptables a la imagen de su mensaje visual. Además, son resistentes y compatibles con multitud de accesorios, lo que les hace un complemento de lo más versátil a la hora de mostrar su cartelería. Apertura por el lado de menor tamaño (lado corto).



12.053	105x148mm	A6	x10 	<input type="text"/>
12.054	148x210mm	A5	x10 	<input type="text"/>
12.055	210x297mm	A4	x10 	<input type="text"/>
12.056	297x420mm	A3	x10 	<input type="text"/>





Poster Protectors

 Antireflectierende Klarsichthülle zum Schutz von Grafiken. Stärke 0,3mm.





 Plastic sleeves, made in glasspack "anti-reflective" 0,3 mm transparent to protect the graphic frames.

 Couvertures de protection en plastique transparent antireflet de 0,3mm pour Frames ABS.

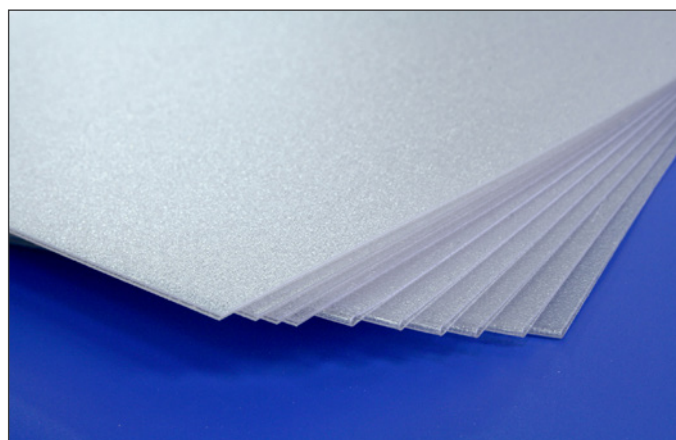
 Capas protectoras realizadas em glasspack "anti reflexo" transparente de 0,3mm para proteger as impressões dos marcos.

 Fundas de plástico, realizadas en glasspack "antireflex", transparente de 0,3mm para proteger la gráfica de los marcos.



12.057	A6	x10 	<input type="text"/>
12.058	A5	x10 	<input type="text"/>
12.059	A4	x10 	<input type="text"/>
12.060	A3	x10 	<input type="text"/>

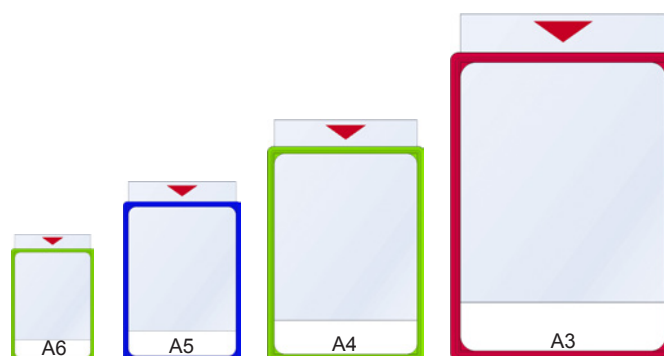

Showcard Stand Extendable

Teleskopständer für ABS Rahmen, bestehend aus Teleskopstange, Metall- oder Kunststofffuß und einen "T - Halter" in transparent. Rahmen nicht inklusive.

Telescopic Racks for ABS frames with "T". Each support consists of a telescopic tube, a (metal or plastic) base and a "T" (transparent). Frames not included.

Support telescopique en forme de T, pour cadres ABS, avec socle métallique ou en plastique. Disponible en transparent. Cadres non inclus.

Suportes telescópicos para marcos ABS em "T". Cada suporte é composto por um tubo telescópico, uma base (metálica ou de plástico) e um "T" (transparente). Não inclui marcos.

Suportes telescópicos para marcos ABS con "T". Cada soporte se compone de un tubo telescópico, una base (metálica o plástico) y una "T" (transparente). No incluyen marcos.

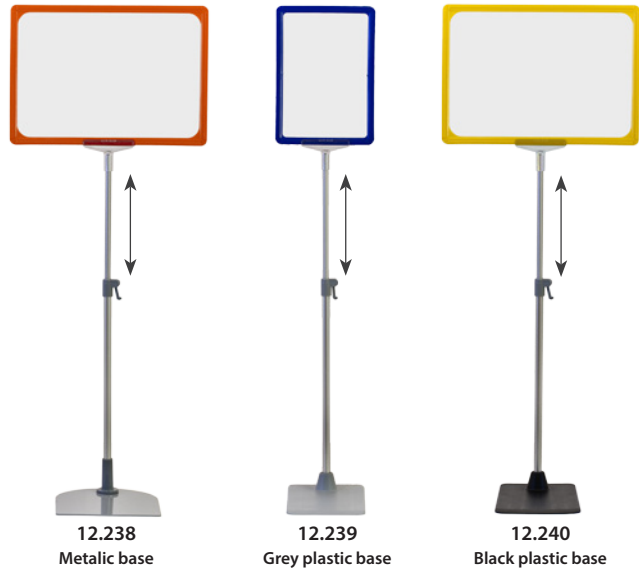

Plastic base				
12.239	150+150	x10		
12.240	150+150	x10		
12.062	300+300	x10		
12.063	300+300	x10		
12.065	500+500	x10		
12.066	500+500	x10		
12.242	750+750	x10		
12.243	750+750	x10		

Metalic base				
12.238	150+150	x10		
12.061	300+300	x10		
12.064	500+500	x10		
12.241	750+750	x10		

Clamp Support for Pallet

Befestigungsklammer für Teleskopständer an Paletten.

Support clamp for placing on pallet telescopic structures.

Pince-support pour placer des structures télescopiques sur palette.

Pinça para a colocação em paleta que permite utilização de um suporte telescópico.

Pinza-soporte para la colocación de estructuras telescópicas sobre pallet.

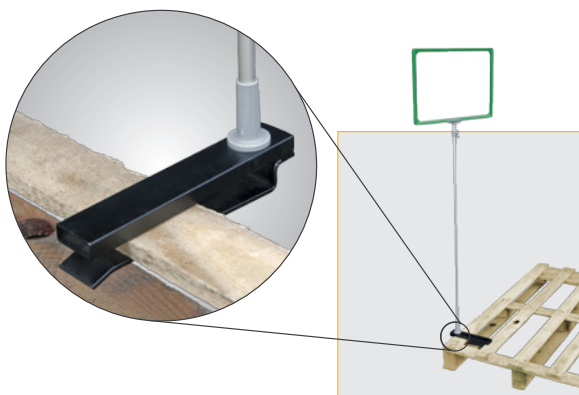

12.400	250mm	x10		
--------	-------	-----	--	--

Showcard Stand with Spring

Teleskophalter für Rahmen mit Feder. Ideal zur Befestigung an Verkaufskörben oder Wühltische aus Drahtgestell. Rahmen nicht inklusive.

Showcard stand with spring. Ideal for placing frames on metal baskets. Frame not included.

Support pour cadres avec ressort. Idéal pour le placement des cadres dans un panier métallique. Cadres non inclus.

Suporte para marco com mola. Ideal para a colocação de marcos em cestos metálicos. Marcos não incluídos.

Suporte para marco con muelle. Ideal para la colocación de marcos en cestos metálicos. Marco no incluido.

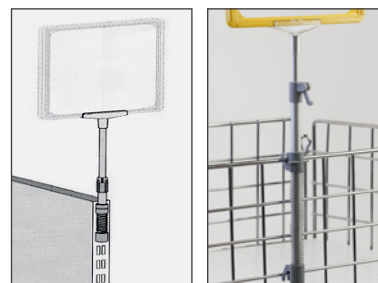

12.069	250mm	x10		
--------	-------	-----	--	--

SHOWCARD FRAMES - SUPPORT

9

Showcard Stand Extendable

Teleskopständer für ABS Rahmen, bestehend aus Teleskopstange 950mm+950mm, Metallfußplatte 240mm und einen "T"- Halter transparent. Maximale Höhe 1900mm. Rahmen nicht inklusive.

Telescopic stand / support for ABS frames with "T". Each support consists of a telescoping tube 950 + 950 mm, 240mm round metal base and a "T" (transparent). Maximum height: 1900mm. Does not include frame.

Support télescopique de 950 + 950 mm pour cadres ABS avec un "T" (transparent) et une base ronde de 240mm. Hauteur jusqu'à 1900mm. Cadres non inclus.

Suporte telescópico para marcos ABS com "T". Cada suporte é composto por um tubo telescópico de 950+950mm, uma base metálica redonda de 240mm e um "T" (transparente). Altura máxima 1900mm. Não inclui marco.

Soporte telescópico para marcos ABS con "T". Cada soporte se compone de un tubo telescópico de 950+950mm, una base metálica redonda de 240mm y una "T" (transparente). Altura máxima de 1900mm. No incluye marco.

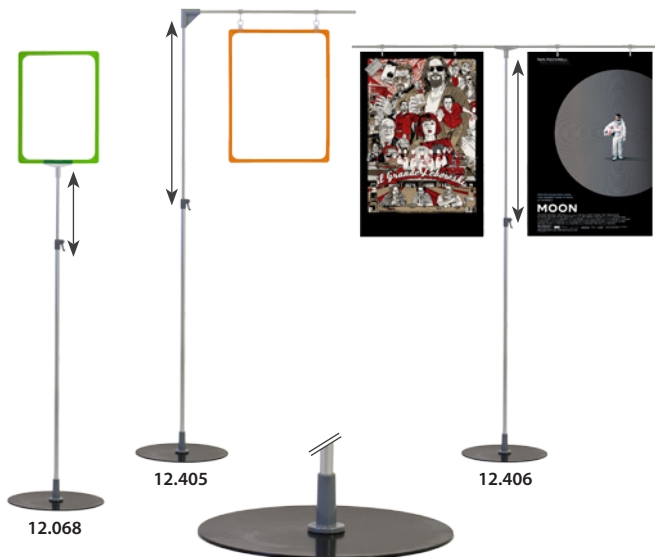

12.068	950+950	x10		
12.406	950+950	x10		
12.405	950+950	x10		

Showcard Stand Extendable "L"

Teleskophalter 500+500mm, Ausleger 500mm mit zwei Grafikaufhängern. Verfügbar in zwei Varianten. Rahmen nicht inklusive.

Telescopic support 500 + 500 mm, 500 mm upper arm and 2 hooks for hanging posters. Available in two models. Frame not included.

Support télescopique de 500+500mm. Bras supérieur de 500mm avec 2 crochets pour la suspension des cadres. Deux modèles disponibles. Cadres non inclus.

Suporte telescópico de 500+500mm, braço superior de 500mm e dois ganchos para pendurar cartazes. Disponível em dois modelos. (Marcos não incluídos).

Soporte telescópico de 500+500mm, brazo superior de 500mm y 2 ganchos para colgar carteles. Disponible en dos modelos. Marco no incluido.

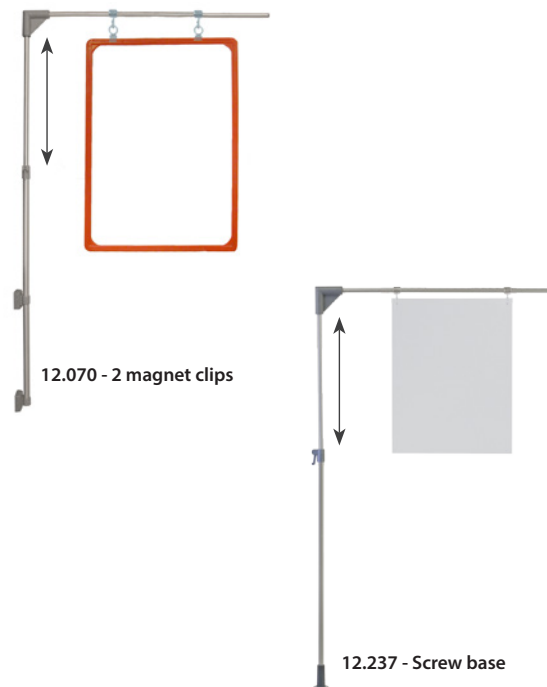

12.070	x20		
12.237	x20		

Showcard Stand Extendable "T"

Teleskophalter 500+500mm für Grafik, in T-Form. Verfügt über einen Ausleger von 1000mm mit Grafikaufhängern. Befestigung mittels Gewinde. Rahmen nicht inklusive.

Telescopic support 500 + 500 mm "T" for fixing frames. It has 1 arm 1000 mm and hooks for hanging posters. Is fixed by a screw holder. (Frame not included).

Support télescopique de 500+500mm. Bras supérieur de 1000mm avec 2 crochets pour la suspension de cadres ou d'affiches. Cadres non inclus.

Suporte telescópico de 500+500mm em "T" para suspensão de marcos. Dispõe de um braço de 1000mm e ganchos para pendurar os cartazes. Fixa-se através de um suporte de rosca. (Marco não incluído).

Soporte telescópico de 500+500mm em "T" para sujeción de marcos. Dispone de 1 brazo de 1000mm y ganchos para colgar cartelería. Se fija mediante un soporte enroscable. (Marco no incluido).



12.075	x20		
--------	-----	--	--

Showcard Stand for Shelf

Auslegerbefestigung für Lamellenwände oder Regalschienen mittels Haken oder Magneten.

Different graphics support for shelf-system. Material: Plastic or steel.

Support pour gondole avec crochets ou aimants pour la suspension d'affiches.

Suporte para gôndolas e segmentos com ganchos ou ímanes para pendurar cartazes.

Soportes para góndolas y lamas con enganches o imanes para colgar cartelería.

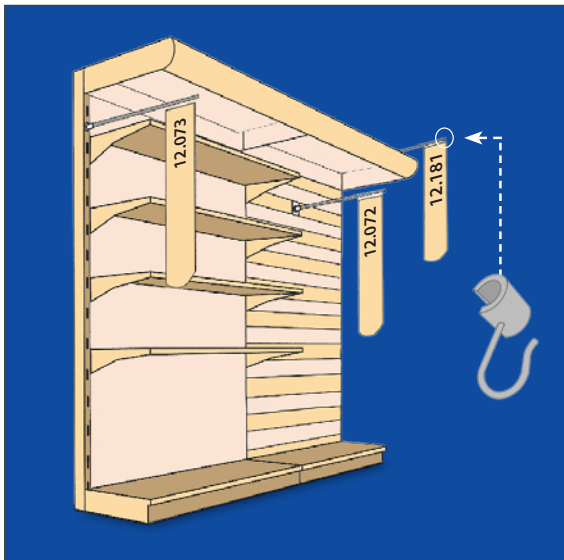

Slatwall Single Hook

12.072 300+300mm x10



Upright Single Hook

12.073 300+300mm x10

Aluminium Banner Holder with Magnet



12.181 300+300mm x10

12.231 400+400mm x10

12.300 500+500mm x10

Single Hook for Tubes

Transparenter Kunststoff-Aufhänger für Ausleger.

Plastic hook for tubes. Ideal for hanging frames in "L" type, combining with Ring Clip. Made of transparent color.

Crochet en plastique transparent, pour tige ou support en "T". Idéal pour la suspension de cadres.

Gancho de plástico para tubo. Ideal para suspender marcos com suporte tipo "L" combinando-o com Anilha Clip. Fabricado em cor transparente.

Gancho en plástico para tubo. Ideal para colgar marcos en soportes tipo "L" combinando con Anilla Clip. Fabricado en color transparente.

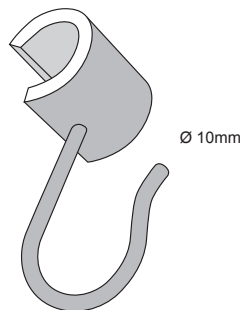

Cardboard Clamp

Transparenter Clip für Rahmenbefestigung an Regalen und Warenkörben. Geeignet für jedes Rahmenformat. Inklusive transparentem T-Halter.

Transparent clamp kit allows its placement in wire baskets and shelves. Allows placement of advertising using a marcockit of any size. Includes clip and transparent "T".

Pinça transparente para quadro que l'on peut placer dans des paniers métalliques ou sur une étagère. Compatible avec toutes les dimensions de cadres ABS. Inclut support en "T" transparent.

Pinça de plástico com "T" incluído para marcos em ABS.

Pinza transparente para marcockit, permite su colocación en cestas metálicas y en estanterías. Permite la colocación de la publicidad mediante un marcockit de cualquier tamaño. Incluye pinza y "T" transparente.

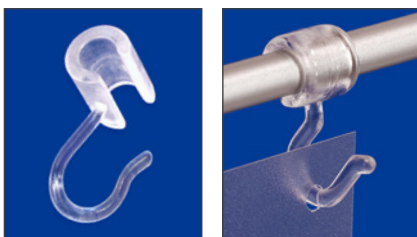
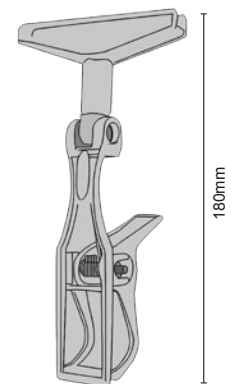

12.076 x20



12.291 180mm x20

Graphic Support

- T-Halter mit Broschürefächern.
- Graphic support for telescopic tube. Material: Plastic.
- Porte visuel à placer sur support télescopique.
- Porta-impressão para colocar sobre o suporte telescópico.
- Portagráficas para colocar sobre el soporte telescópico.



12.338

x25

"T"

- T-Halter zur Befestigung von Rahmen. Verfügbar in vier Farben.
- Support "T" for fixing frames. Available in four colors.
- Support en "T" pour fixer les cadres. Disponible en quatre couleurs.
- Suporte "T" para fixação de marcos. Disponíveis em quatro cores.
- Soporte "T" para sujeción de marcos. Disponible en cuatro colores.



12.077

x20

Tube Clip

- Transparenter Clip für Rahmenbefestigung an Stangen.
- Tube clip. Transparent colour. Material: Plastic.
- Crochet en plastique transparent à fixer sur tubes.
- Clip para fixar em tubos. Fabricado em cor transparente.
- Clip de enganche para tubos. Fabricado en color transparente.



12.081 Ø 18mm

x20

12.082 Ø 22mm

x20

12.083 Ø 26mm

x20

Wall Fix Clip

- Transparenter Clip für Rahmenbefestigung an Wänden.
- Wall Fix clip for wall frames. Suitable for front fastening. Transparent.
- Crochet pour fixer des cadres au mur. Fixation frontale. Fabriqué en couleur transparente.
- Clip de enganche à parede para marcos. Indicado para fixação frontal. Fabricado em cor transparente.
- Clip de enganche en pared para marcos. Indicada para sujeción frontal. Fabricado en color transparente.



12.080

x20

Connecting Clips

- Transparenter Clip zum Verbinden von mehreren Rahmen.
- Connecting clips. For connecting some frames. Plastic.
- Clips pour assembler plusieurs cadres.
- Clip para união de vários marcos.
- Clip para la unión de varios marcos.

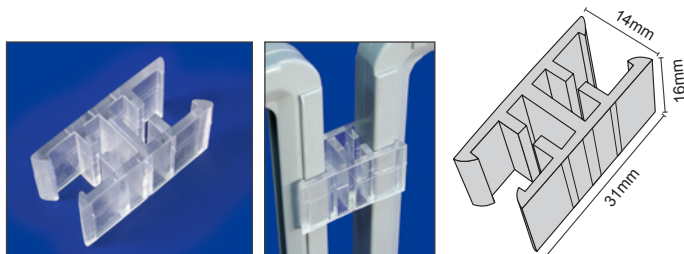

12.087

x20

Basket Clip

- Transparenter Clip für Rahmenbefestigung an Warenkörben.
- Hanging hook. Wire basket row clip. Material: Plastic.
- Clip pour fixation des cadres à des paniers.
- Clip para fixação de marcos a cestos.
- Clip para la sujeción de marcos a cestos.

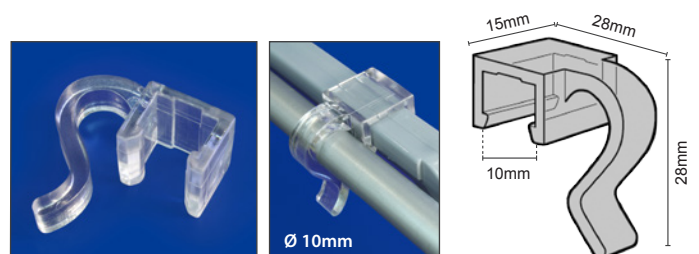

12.084

x20

Promo Showcard Clip

Transparenter Clip zur Befestigung von Werbeschildern an Rahmen.

Promo showcard clip. For graphics. Material: Plastic.

Clip permettant la fixation d'affichages publicitaires.

Clip para fixação de cartazes publicitários.

Clip para la sujeción de carteles publicitarios.

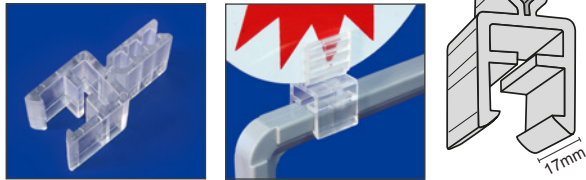

12.088

x20

Clip for Ceiling-Rail

Transparenter Clip zur Rahmenbefestigung an Profilschienen.

Clip for ceiling-rail. Material: Plastic.

Clip pour adapter les cadres aux profilés.

Clip para adaptar os marcos aos perfis.

Clip para acoplar los marcos a los perfiles.



12.089

x20

Ring Clip

Transparente Aufhänge-Öse für Rahmen, drehbar.

Rotating ring with clip frames. Suitable for upper clamp. Transparent.

Anneau rotatif avec pince pour cadres. L'accrochage se fait par la partie supérieure du cadre. Fabriqué en plastique transparent.

Anilha giratória com pinça para marcos. Indicada para suspensão superior. Fabricado em cor transparente.

Anilla giratoria con pinza para marcos. Indicada para sujeción superior. Fabricado en color transparente.

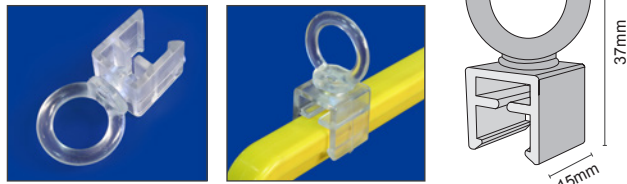

12.090

x20

Hook Clip 10mm

Transparenter Aufhängehaken für Rahmen, Durchmesser 10mm.

Hook clip Ø 10mm, for showcard frames. Suitable for upper clamp.

Crochet clip de 10mm permet la suspension de cadre par le haut. Fabriqué en couleur transparente.

Gancho clip para suspensão de 10mm para marcos. Indicado para suspensão na parte superior. Fabricado em cor transparente.

Gancho clip colgador de 10mm, para marcos. Indicado para sujeción en la parte superior. Fabricado en color transparente.

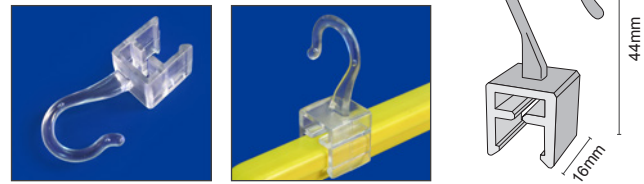

12.091

x20

Tube Clamp

Transparenter T-Halter mit Schelle zur Befestigung von Rahmen an Kleiderstangen, Gitterwänden und Warenkörben. Geeignet für jedes Rahmenformat.

Marcokit support that can be placed in laundry bars, baskets or grating panels. Allows placement of advertising by using a marcockit of any size. Includes support and transparent "T".

Support pour cadres à fixer sur panier, grille ou porte vêtement. Possibilité d'utiliser avec toutes les dimensions des cadres. Support en "T" inclus.

Suporte marcockit que pode ser colocado em barras de roupa, cestas ou painéis gradeados. Permite que se coloque publicidade através de um marcockit de qualquer tamanho. Inclui suporte e "T" transparente.

Soporte de marcockit que puede ser colocado en barras de ropa, cestas o paneles de rejilla. Permite la colocación de la publicidad mediante un marcockit de cualquier tamaño. Incluye soporte y "T" transparente.



12.292

Ø 30mm

x20

Hook Clip 20mm

Transparenter Aufhängehaken für Rahmen, Durchmesser 20mm.

Hook clip Ø 20mm, for showcard frames. Transparent colour. Material: Plastic. Suitable for upper clamp.

Crochet clip de 20mm pour la suspension des cadres par le haut. Fabriqué en couleur transparente.

Gancho clip para suspensão de 20mm para marcos. Indicado para suspensão na parte superior. Fabricado em cor transparente.

Gancho clip colgador de 20mm, para marcos. Indicado para sujeción en la parte superior. Fabricado en color transparente.

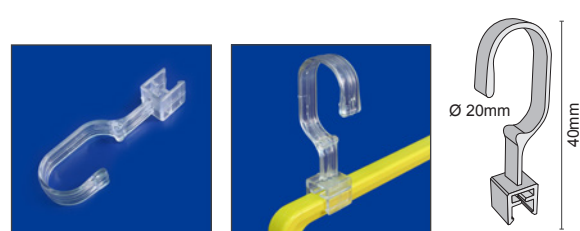

12.092

x20

Magnetic Clip Connector



- Magnethalter zur Rahmenbefestigung.
- Connector framework, used as magnetic plug type.
- Connecteur pour cadre à utiliser comme support magnétique d'accroche.
- Conector directo ao marco para utilizar como suporte magnético tipo encaixe.
- Conector para marco, empleado como soporte magnético de tipo enchufe.

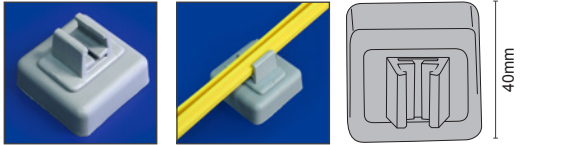

12.096

x20

Medium Magnetic Clip



- Magnethalter zum Stabilisieren von Stangenbefestigungen.
- Magnet for aluminum tube for using as intermediate support.
- Aimant pour tube d'aluminium, permet l'utilisation d'un support intermédiaire.
- Base magnética para tubo. Material: Plástico.
- Imán para tubo de aluminio, para utilizar como soporte intermedio.



12.097

x20

Lateral Clip

- Transparenter Aufhängerhaken für Rahmen. Haken wird an den Rahmenseiten aufgesteckt.
- Side hook for holding plastic frames. Made of transparent color.
- Crochet latéral en plastique transparent permettant la suspension des cadres.
- Gancho lateral de plástico para suspensão de marcos. Fabricado em cor transparente.
- Gancho lateral de plástico para sujeción de marcos. Fabricado en color transparente.

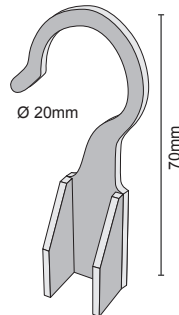

12.094

x20

← 10 Uni.
→ 10 Uni.

Base Support Clip

- Rahmenaufsteller.
- Frame base support clip. Material: Plastic.
- Support permettant de poser un cadre.
- Suporte para marcos.
- Soporte para marcos.

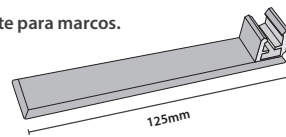

12.093

x10

End-Magnetic Clip



- End-Magnethalter zur Befestigung von Aluminiumstangen.
- End-magnetic clip for aluminium tube. Material: Plastic.
- Embout aimanté pour tube d'aluminium.
- Imã terminal para tubo de alumínio.
- Imán terminal para tubo de aluminio.



12.098

x20

Magnetic "T" Base



- T-Halter mit Magnet zur Rahmenbefestigung. Rahmen nicht inklusive.
- Magnetic base with short T-connector. Frame not included.
- Support en "T" magnétique pour cadres. Cadre non inclus.
- Base magnético com "T". Marco não incluído.
- Soporte "T" para sujeción de marcos con imán. (Marco no incluido).

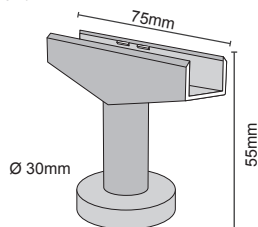
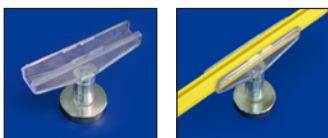

12.079

x20

Magnetic Clip for Frames



- Magnetfuß für Rahmenbefestigung.
- Magnetic feet clip for showcard frames. Plastic.
- Socle magnétique pour cadres.
- Pé magnético para marcos.
- Pie magnético para marcos.



12.099

x20

MINI SHOWCARD FRAMES - ACCESSORIES

Clear Frames

Transparenter Kunststoffrahmen, extra schmal. Hochwertige Qualität und äußerst resistent. Zusätzliche Gestaltungsmöglichkeiten durch das Kombinieren mit anderem Zubehör. Rahmenöffnung an den Stirnseiten.

Lightweight Showcard frame, manufactured in high quality transparent plastic. Available in transparent and fully adaptable to the visual message of its color. In addition, they are resistant and compatible with many accessories. Opening on the smaller side (short side).

Cadres extrafins fabriqués en plastique transparent de grande qualité. Disponibles en couleur transparente, résistants et compatibles avec beaucoup d'accessoires. Ouverture par le petit coté.

Marco de plástico transparente extra fino com ranhura para a introdução da imagem. Disponível em vários tamanhos.



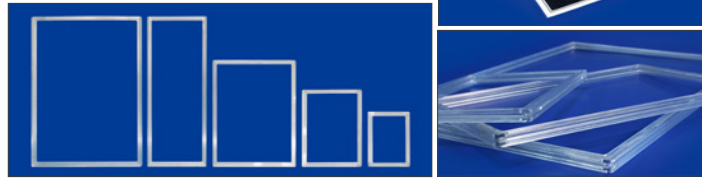

Marcos extrafinos, fabricados en plástico transparente de alta calidad. Son resistentes y compatibles con multitud de accesorios. Apertura por el lado de menor tamaño (lado corto).

 clear

12.336	74x105mm	A7	x10 	<input type="checkbox"/>
12.322	105x148mm	A6	x10 	<input type="checkbox"/>
12.323	148x210mm	A5	x10 	<input type="checkbox"/>
12.324	105x297mm	1/2A4	x10 	<input type="checkbox"/>
12.325	210x297mm	A4	x10 	<input type="checkbox"/>



Poster Protectors

12.337	A7	x10 	<input type="checkbox"/>
12.057	A6	x10 	<input type="checkbox"/>
12.058	A5	x10 	<input type="checkbox"/>
12.328	1/2A4	x10 	<input type="checkbox"/>
12.059	A4	x10 	<input type="checkbox"/>

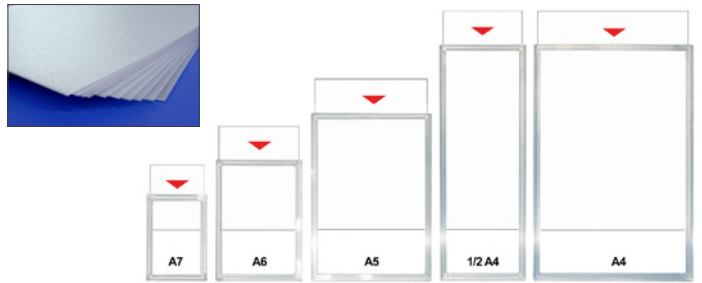



Hanging Hook



12.095 x20   10 Uni.
 10 Uni.

Frame Connector



12.334 x20 

Base Clip

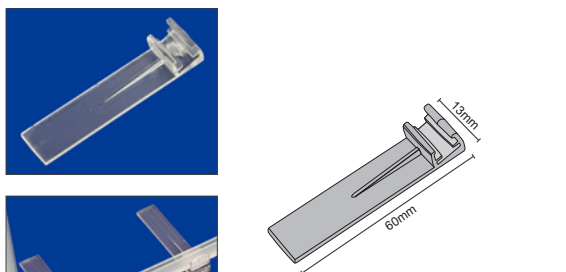

12.333 x20 

Hanging Hook



12.335 x20 

Promotion Clip



12.332 x20 

SIGN CLIP

9

"B" Big Clip

Transparenter Preishalter aus Kunststoff. Die B-Serie besteht aus einer 25mm breiten Befestigungsklammer und der Grafik-Halterung.

Price holders made in clear plastic; the "B" series are formed by a lower clamp of 25mm wide and an upper attachment.

Porte étiquette, en plastique transparent, avec pince de 25mm de large et un accessoire supérieur.

Pinça com um grampo de alta resistência. Largura da pinça de 25mm.

Portaprecios realizados en plástico incoloro; la serie "B" está formada por una pinza inferior de 25mm de ancho y un accesorio superior.

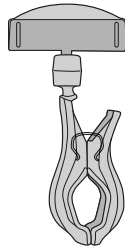
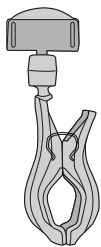

12.004 x25

12.007 x25

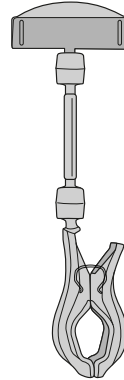

12.008 x25

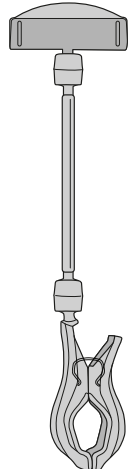

12.009 x25

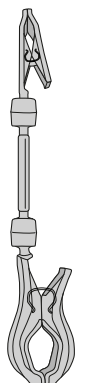
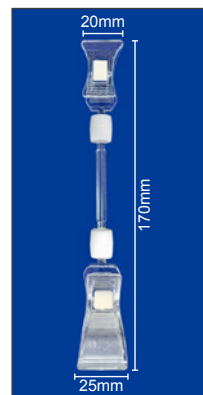
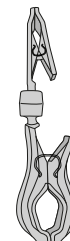
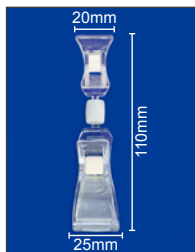
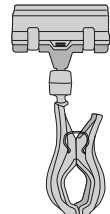
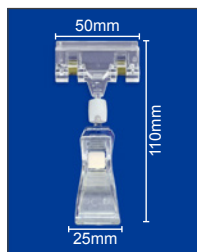
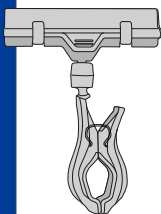
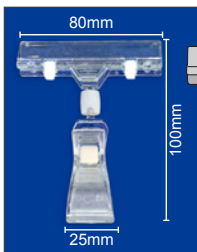
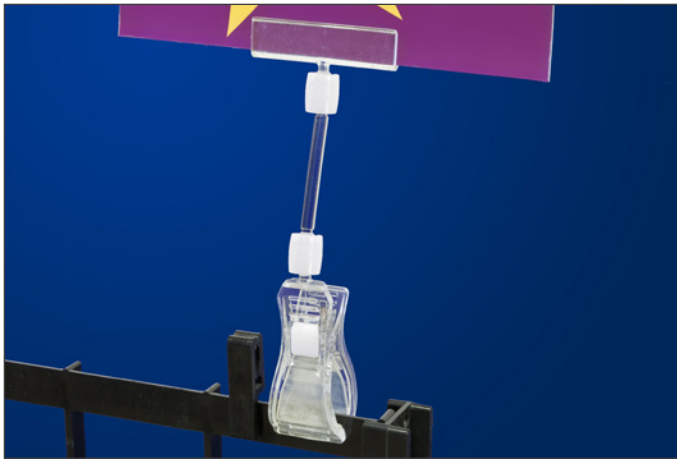

12.000 x25

12.001 x25

12.010 x25

12.011 x25

SIGN CLIP

"C" Medium Clip

Transparenter Preishalter aus Kunststoff. Die C-Serie besteht aus einer 20mm breiten Befestigungsklammer und der Grafik-Halterung.

Price holders made in clear plastic; the "C" series are formed by a lower clamp of 20mm wide and an upper attachment.

Porte étiquette, en plastique transparent, avec pince de 20mm de large et un accessoire supérieur.

Pinça com um grampo de alta resistência. Largura da pinça de 20mm.

Portaprecios realizados en plástico incoloro; la serie "C" está formada por una pinza inferior de 20mm de ancho y un accesorio superior.

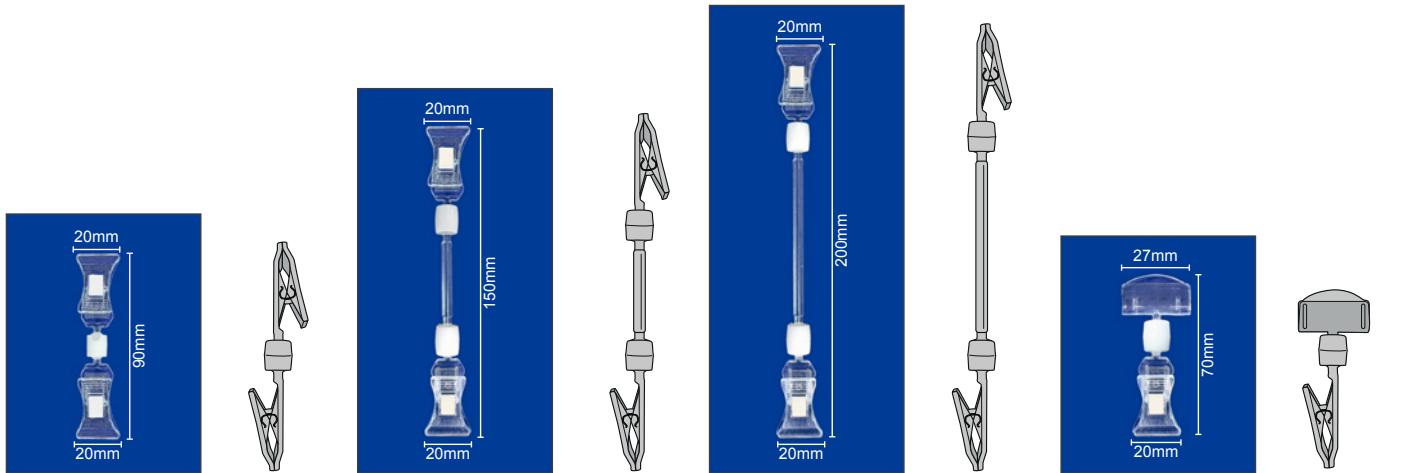

12.015 x25

12.016 x25

12.017 x25

12.020 x25

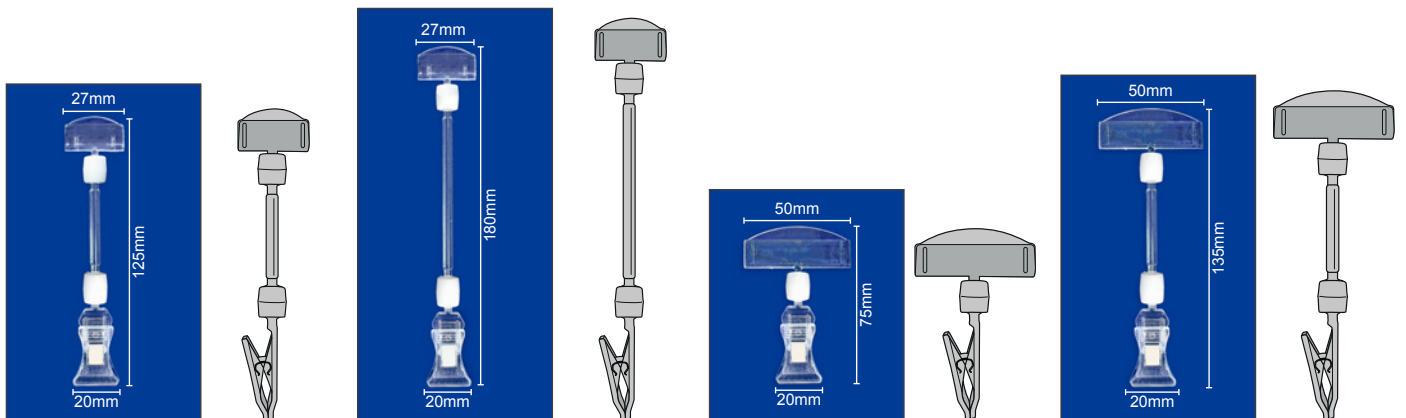
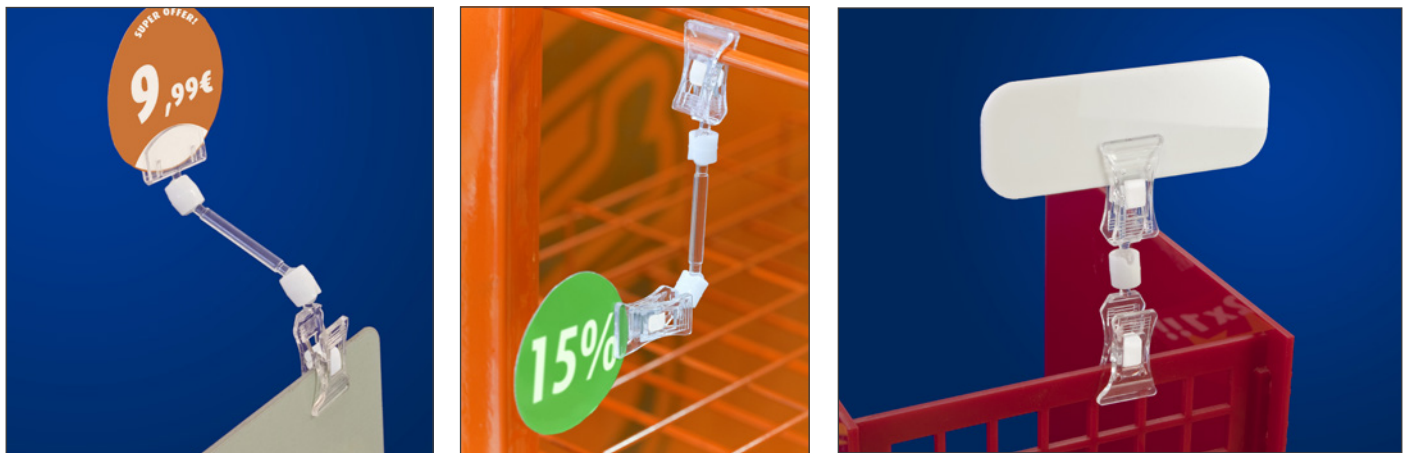

12.021 x25

12.022 x25

12.025 x25

12.026 x25

SIGN CLIP

9

"G" Magnetic Clip



Transparenter Preishalter aus Kunststoff. Die G-Serie besteht aus einer 20mm breiten Befestigungsklammer und der Grafik-Halterung.

Price holders made in clear plastic; the "G" series consist of a magnet of 20mm diameter at the bottom and a fixture in the top.

Porte étiquette, en plastique transparent, avec aimant de 20mm de diamètre et un accessoire dans la partie supérieur.

Transparenter Preishalter aus Kunststoff. Die G-Serie besteht aus einem 20mm breiten Magnethalter und der Grafik-Halterung.

Portaprecios realizados en plástico incoloro; la serie "G" está formada por un imán de 20mm de diámetro en su parte inferior y un accesorio en la parte superior.



12.029 x25



12.030 x25

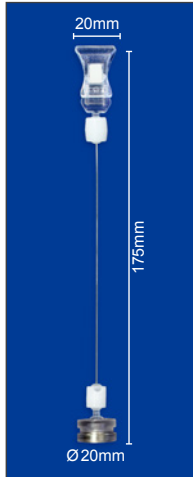

12.031 x25

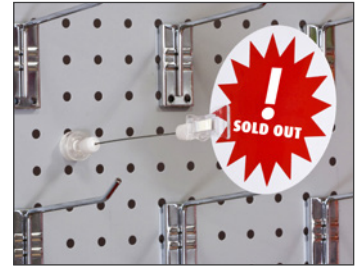

12.034 x25

"H" Table Clip Ø 90mm

Transparenter Preishalter aus Kunststoff. Die H-Serie besteht aus einem 90mm breiten Fuß und der Grafik-Halterung.

Price holders made in clear plastic; the "H" series are formed by a base diameter of 90mm and an upper attachment.

Porte étiquette, en plastique transparent, composée d'une base de 90mm de diamètre et d'un accessoire supérieur.

Portapreços realizados em plástico incoloro. A série "H" possui uma base 90mm de diâmetro e um acessório superior.

Portaprecios realizados en plástico incoloro; la serie "H" está formada por una base de 90mm de diámetro y un accesorio superior.

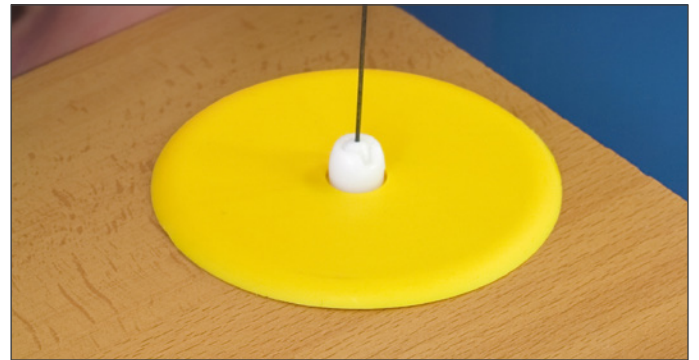

12.035 x25



12.036 x25







12.037 x25



12.038 x25

"I" Table Clip Ø 55mm

-  Transparenter Preishalter aus Kunststoff. Die I-Serie besteht aus einem 55mm breiten Fuß und der Grafik-Halterung.
-  Price holders made in clear plastic; Series "I" are formed by a base diameter of 55mm and an upper attachment.
-  Porte étiquette, en plastique transparent, composée d'une base de 55mm de diamètre et d'un accessoire supérieur.
-  Portapreços realizados em plástico incolor. A série "I" possui uma base inferior de 55mm de diâmetro e um acessório superior.
-  Portaprecios realizados en plástico incoloro; la serie "I" está formada por una base de 55mm de diámetro y un accesorio superior.



12.039 x25 







12.040 x25 



12.042 x25 



"K" Suction Clip

-  Transparenter Preishalter aus Kunststoff. Die K-Serie besteht aus einem 40mm breiten Saugnapf und der Grafik-Halterung.
-  Price holders made in clear plastic. Incorporating a lower suction 40mm diameter and a top accessory.
-  Porte étiquette, en plastique transparent, composée d'une ventouse de 40mm de diamètre et d'un accessoire supérieur.
-  Portapreços realizados em plástico incolor. Formados por uma ventosa inferior de 40mm de diâmetro e um acessório superior.
-  Portaprecios realizados en plástico incoloro. Formados por una ventosa inferior de 40mm de diámetro y un accesorio superior.



12.045 x25 



12.046 x25 

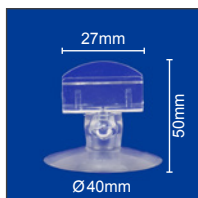

12.048 x25 



SIGN CLIP

9

"Q" Sign Support

- Preishalter aus Stahl mit Fuß, Teleskopstab und transparenten Klammern.
- Price holders made of steel; telescopic and colorless plastic clips holding chart.
- Support télescopique en acier, avec pince en plastique pour la fixation des visuels.
- Suporte telescópico com três alturas diferentes. Material: Aço e plástico.
- Portaprecios realizados en acero; telescópicos y con pinzas de plástico incoloro para sujeción de gráfica.

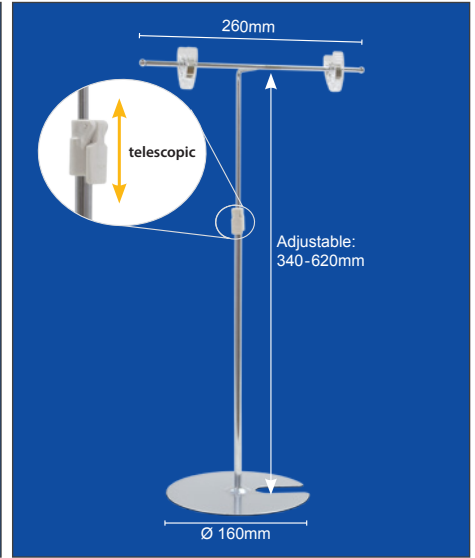
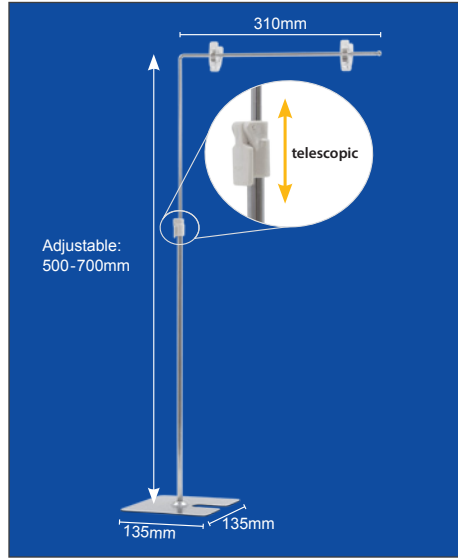
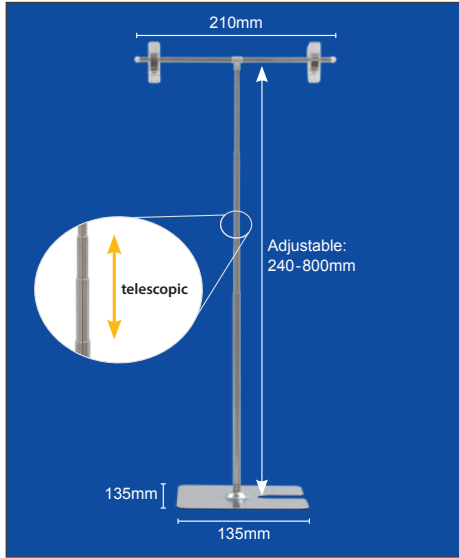
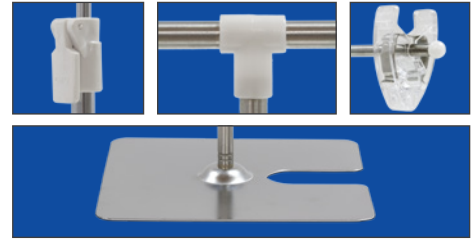

12.050 x10



12.051 x10



12.052 x10



Clip Strip

- Blisterleiste aus Kunststoff in verschiedenen Längen. Ideal für eine übersichtliche und flexibel einsetzbare Warenpräsentation.
- Clip strip of plastic of different sizes for the display of products in an orderly and secure form.
- Bande clip en plastique, pour l'exposition des produits. Plusieurs dimensions disponibles.
- Clip strip de plástico de diferentes medidas para a exposição de produtos de maneira ordenada e simples.
- Clip strip de plástico de diferentes medidas para la exposición de productos de manera ordenada y sencilla.



12.226

12.226 x50

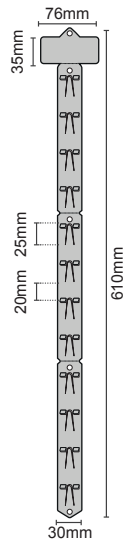

12.227

12.227 x50

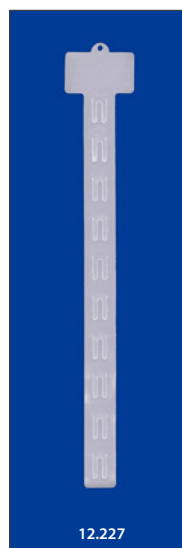

12.228

12.228 x50

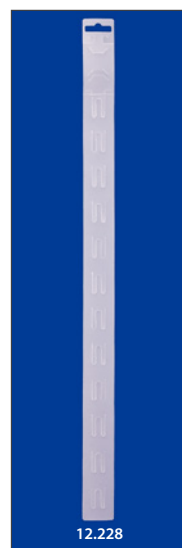



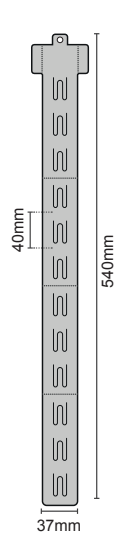
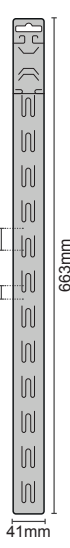

12.229

12.229 x50



Rotating Ceiling Button

-  Befestigungssysteme für Grafiken. Ist für verschiedene Untergrundmaterialien geeignet, wie z.B. Metall, Glas, Decken, etc.
-  Different systems for the attachment and placement of "suspended" graphics. They adapt to different surfaces that can be metal, glass, on ceilings, etc.
-  Système de fixation et suspension de visuels. S'adapte à tous types de superficies telles que le métal, le verre, etc.
-  Diferentes sistemas para a fixação e colocação de impressões suspensas. Adaptam-se a diferentes superfícies como o metal, o vidro, o tecto, etc.
-  Distintos sistemas para la fijación y colocación de gráficas "suspendidas". Se adaptan a distintas superficies como pueden ser metal, vidrio, techos, etc.

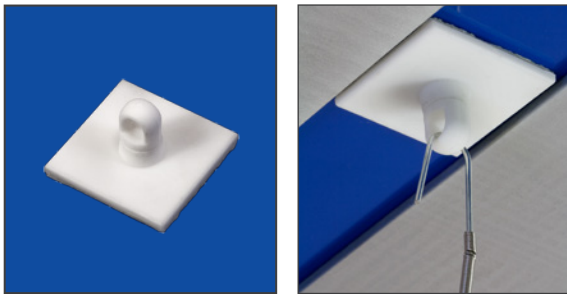
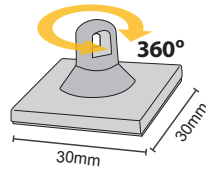



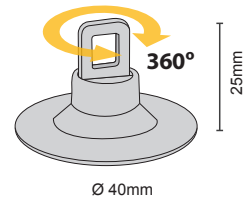

12.113 30x30mm x100 



12.384 Ø 40mm x100 

Mobile Button

-  Selbstklebende Aufhänge-Öse in Weiß.
-  Adhesive button with closed hook in white colour.
-  Bouton adhésif avec crochet fermé fabriqué en plastique blanc.
-  Botão adesivo com presilha. Cor branca.
-  Botón adhesivo con gancho cerrado. Color blanco.

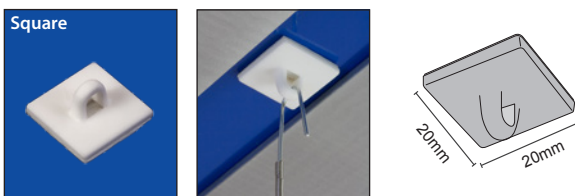

12.129 20x20mm x100 

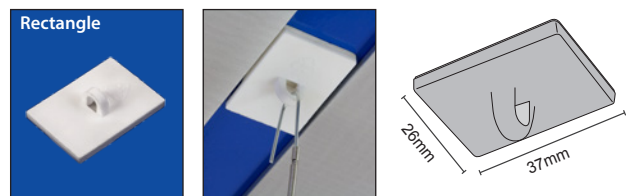

12.130 37x26mm x100 

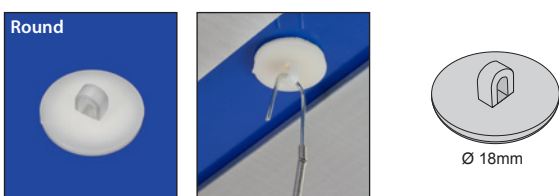

12.301 Ø 18mm x100 

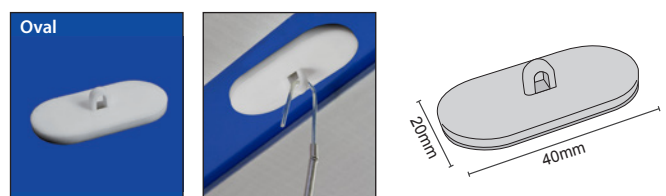

12.368 40x20mm x100 

Adhesive Multiclip



- Selbstklebender Mehrzweck-Clip in weiß. Kunststoff.
- White multipurpose self adhesive button. Plastic.
- Clip adhésif fabriqué en plastique blanc.
- Clip adhesivo de plástico.
- Clip adhesivo de múltiples usos.

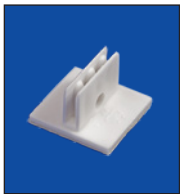
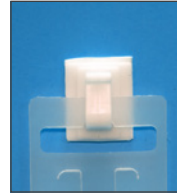
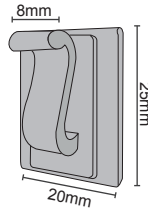
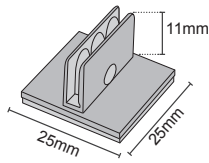

12.134 25x25mm x100

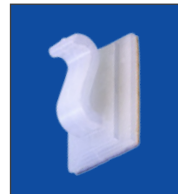

12.484 20x25mm x100

Ceiling Hook

- Selbstklebender Polypropylen-Haken in weiß. Material: Kunststoff.
- Adhesive button with open hook, that facilitates the open exchange of signage. Colour: white.
- Bouton adhésif avec crochet ouvert fabriqué en plastique blanc.
- Botão adesivo de gancho aberto, o gancho aberto facilita a mudança de cartazes. Cor branca.
- Botón adhesivo con gancho abierto, el gancho abierto facilita el intercambio de la cartelería. Color blanco.

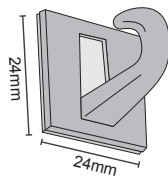

12.131 24x24mm x100

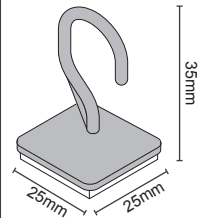

12.447 25x25mm x100



Vertical Clip for Ceiling

- Aufhängeöse 23x20mm mit Klemmbefestigung an Deckenschienen.
- Ceiling tee hanger. Natural polypropylene clip on hanger. Plastic.
- Clip vertical pour rail de faux plafond.
- Clip vertical para os carris de tectos falsos.
- Clip vertical para los railes de los falsos techos.

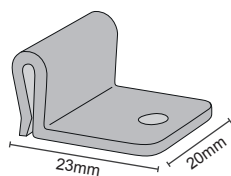
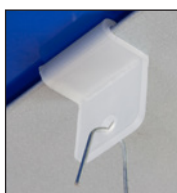
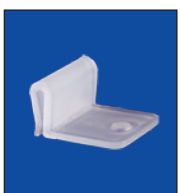

12.132 23x20mm x100



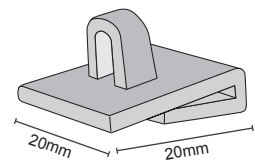
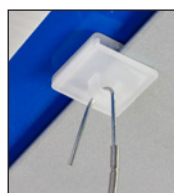

Horizontal Clip for Ceiling

- Aufhängeöse 20x20mm mit Klemmbefestigung an Deckenschienen.
- Clear polypropylene. Clips to ceiling tees. Plastic.
- Clip horizontal pour rail de faux plafond.
- Clip horizontal para os carris de tectos falsos.
- Clip horizontal para los railes de los falsos techos.



12.133 20x20mm x100

Pen Clip

-  Selbstklebender Befestigungs-Clip für Kulis und Stifte.
-  Pen holder. Suitable for standard pens and pencils, with adhesive. Plastic.
-  Bouton adhésif pour la fixation de stylo, crayon, etc.
-  Botão adesivo ideal para fixar canetas, lapiseiras, etc.
-  Botón adhesivo ideal para la fijación de bolígrafos, lapiceros, etc.

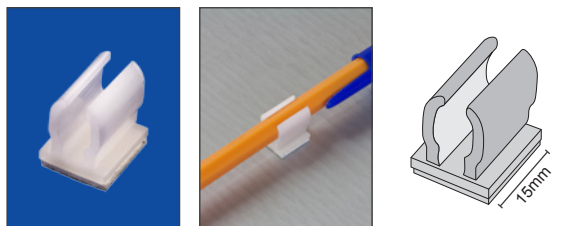



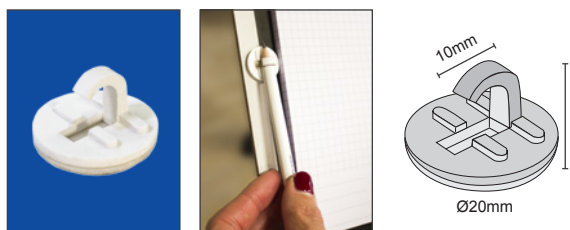

12.182 12x15mm x100 



12.448 Ø20x13mm x100 



CD Holder

-  Selbstklebender CD-Halter, in drei verschiedenen Farben.
-  CD holder with foam tape, three diferents colours.
-  Support adhésif pour CD, disponible en 3 couleurs.
-  Suporte para CD com adesivo. Disponível em três cores.
-  Porta CD, disponible en tres colores.

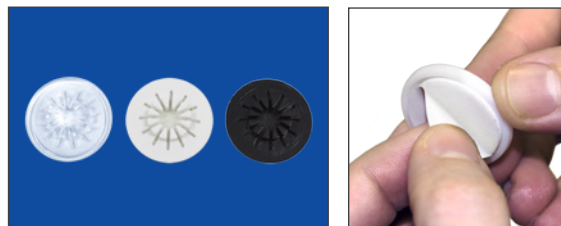





12.486 White

12.487 Clear

12.488 Black x100 

Plastic Hook

-  Weiße Kunststoffhaken.
-  Plastic hook. Can be attached to various systems or directly to posters.
-  Crochet en plastique blanc.
-  Gancho de plástico branco.
-  Gancho de plástico. Puede acoplarse a distintos sistemas o directamente a cartelería.

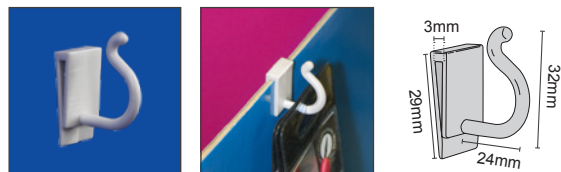

12.074 24x29 mm x50 



12.485 28x26x43mm x50 

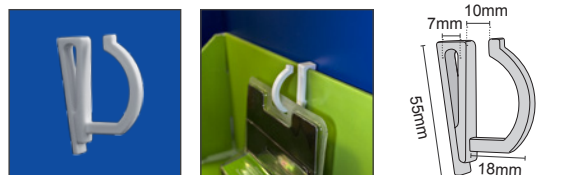

12.279 55x37mm x50 

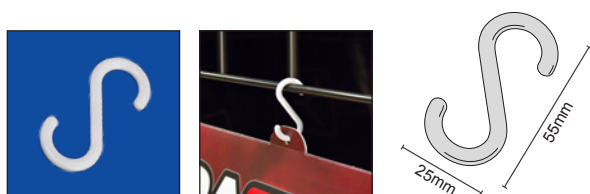

12.293 55mm x50 

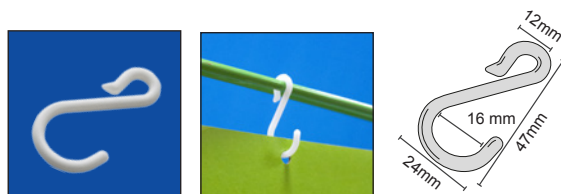

12.377 47mm x50 

"Fishing Clip"

🇩🇪 Deckenklemme für Zwischendecke.

🇬🇧 Spring metal clip for ceiling tee grids. Steel.

🇫🇷 Crochet pour faux plafond. S'accroche au faux plafond et reste immobilisé sur lui-même.

🇪🇸 Gancho metálico para teto falso.

🇪🇸 Gancho para falso techo, se engancha al falso techo y queda inmovilizado en el mismo.

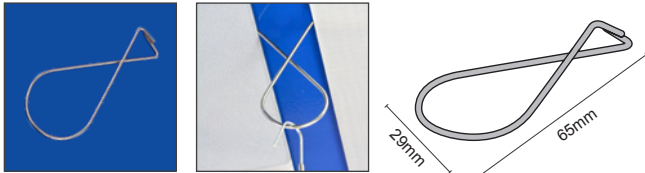

12.136 65x29mm x100

"Spider Clip"

🇩🇪 Deckenspinne aus Stahl für Zwischendecke.

🇬🇧 Suspended ceiling clip. For hanging poster, showcard, etc. from suspended ceiling. Material: Steel.

🇫🇷 Crochet araignée pour rails de faux plafond. Fabriqué en acier.

🇪🇸 Gancho aranha para carris de tecto falso. Fabricado em aço.

🇪🇸 Gancho araña para raíles de los falsos techos. Fabricado en acero.

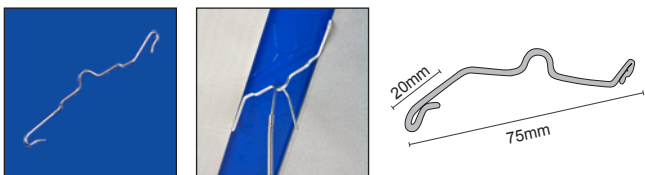

12.135 75x20mm x100

"Easy Clip"

🇩🇪 Deckenklemme für Zwischendecke.

🇬🇧 Spring metal clip for ceiling tee grids. Material: Steel.

🇫🇷 Crochet pour faux plafond. S'accroche au faux plafond et reste immobilisé sur lui-même.

🇪🇸 Gancho metálico para teto falso.

🇪🇸 Gancho para falso techo, se engancha al falso techo y queda inmovilizado en el mismo.

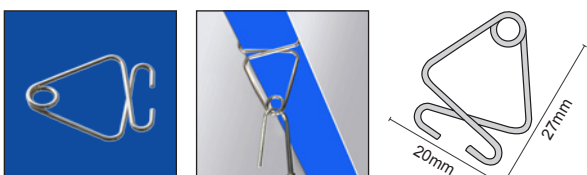

12.387 20x27mm x100

Adjustable Ceiling

🇩🇪 Längenverstellbarer Haken aus Stahl, Länge bis zu 2m.

🇬🇧 Adjustable ceiling hook. Two parts ceiling hook. Adjustable 2m. Material: Steel.

🇫🇷 Crochet ajustable en hauteur. Permet une extension jusqu' à 2m. Fabriqué en acier.

🇪🇸 Gancho ajustável em altura; pode chegar a alcançar os 2m de extensão. Fabricado em aço.

🇪🇸 Gancho ajustable en altura que puede llegar a alcanzar los 2m de extensión. Fabricado en acero.

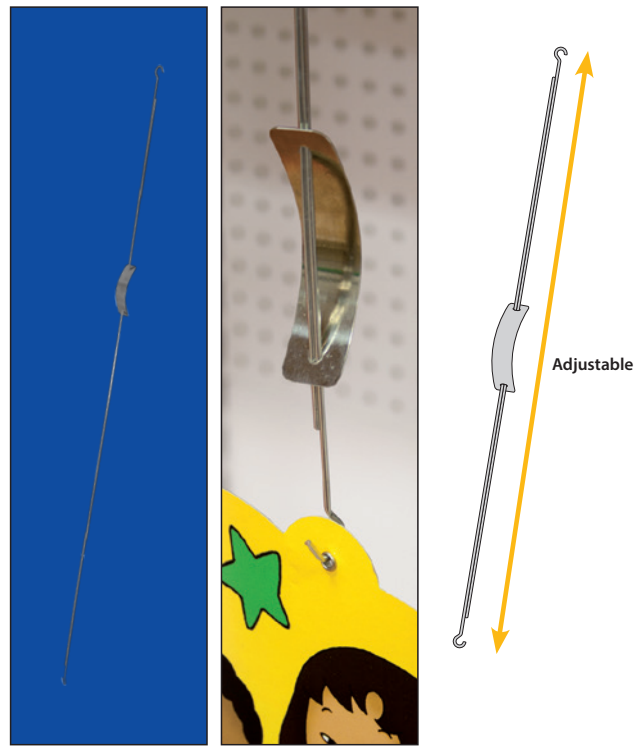

12.151 1000-2000mm x50

Nylon Wire with Hook

🇩🇪 Haken 105mm mit äußerst resistenstem Nylonfaden 1200mm.

🇬🇧 Metal hook and nylon wire with metal tip. Hook ±105mm, nylon ±1200mm.

🇫🇷 Crochet avec fil de nylon de grande résistance pour des affiches. Crochet ± 105mm Fil ± 1200mm.

🇪🇸 Gancho com fio de nylon de grande resistência para cartazes. Gancho ± 105mm fio ± 1200mm.





🇪🇸 Gancho con hilo de nylon de gran resistencia para la cartelería. Gancho ± 105mm, Hilo ± 1200mm.



12.137 x100





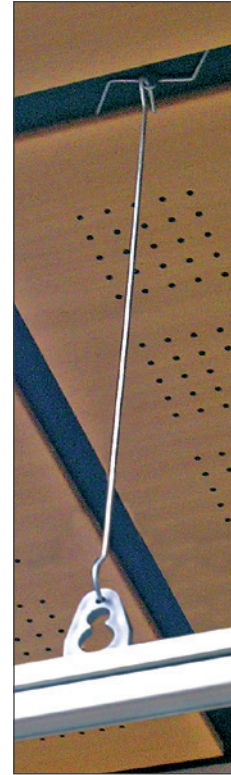

Double Ended Hooks

-  Drahthaken, geeignet für verschiedene Befestigungssysteme.
-  Bright galvanised double ended hooks for suspending and connecting signs. Steel.
-  Baguette avec double crochet pour s'adapter à différents systèmes pour la fixation d'affiches.
-  Vara com gancho duplo para adaptar aos diferentes sistemas de suspensão de cartazes.
-  Varilla con doble gancho para acoplar a los diferentes sistemas para colgar cartelaría.

12.141	100mm	x50 	<input type="text"/>
12.142	150mm	x50 	<input type="text"/>
12.143	200mm	x50 	<input type="text"/>
12.144	300mm	x50 	<input type="text"/>
12.145	400mm	x50 	<input type="text"/>
12.146	500mm	x50 	<input type="text"/>
12.147	600mm	x50 	<input type="text"/>
12.148	750mm	x50 	<input type="text"/>
12.149	900mm	x50 	<input type="text"/>
12.150	1000mm	x50 	<input type="text"/>







Extending Wire Hook

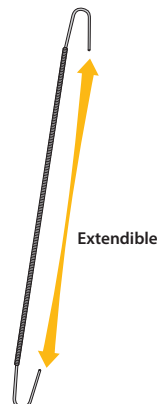

-  Doppel-Haken mit Feder.
-  Double extensible with spring hook.
-  Crochet extensible de double ressort.
-  Gancho extensível com mola dupla.
-  Gancho extensible doble con muelle.

12.138	160-1300mm	x100 	<input type="text"/>
12.139	210-1400mm	x100 	<input type="text"/>
12.140	320-2500mm	x50 	<input type="text"/>



"C" Hook

-  C-Haken zum Abhängen von Schildern, Plakaten usw.
-  "C" hook. You can engage with the clip button or directly to structures.
-  Crochet en "C". Peut s'adapter aux boutons clip ou directement aux structures.
-  Gancho em "C". Pode adaptar-se aos botões clip ou directamente às estruturas.
-  Gancho en "C". Puede acoplarse a los botón clip o directamente a las estructuras.

12.155	80mm	x100 	<input type="text"/>
12.156	39mm	x100 	<input type="text"/>

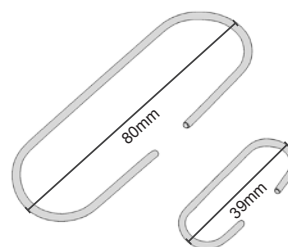

Hook for Clip Strip

- Haken für Blisterleisten.
- Hook for clip strip. Material: Steel.
- Crochet pour bande clip.
- Gancho para clip strip.
- Gancho para clip strip.



12.157 38mm x100

"S" Hook

- S-Haken zur Befestigung an Aufhänger-Ösen oder Stangensystemen.
- "S" hook. You can engage with the clip button or directly to structures.
- Crochet en "S" qui peut s'adapter aux boutons clip ou directement aux structures.
- Gancho em "S". Pode adaptar-se aos botões clip ou diretamente às estruturas.
- Gancho en "S". Puede acoplarse a los botón clip o directamente a las estructuras.

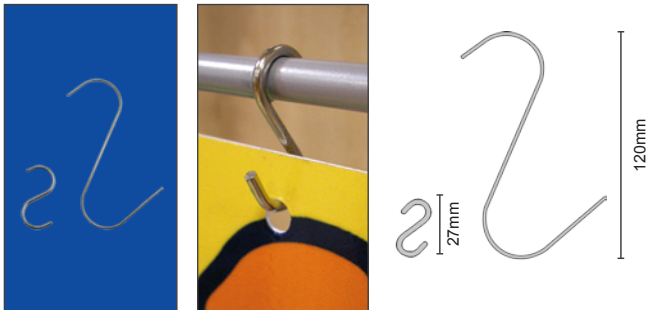

12.152 27mm - Ø1,1mm x100

12.154 120mm - Ø2mm x100

Oval Pop-Ring

- Ovaler Kunststoffring zur schnellen und einfachen Aufhängung.
- Oval plastic ring easy to use and quick installation.
- Anneau ovale de plastique, facile d'utilisation et mise en place rapide.
- Anilha oval de plástico de fácil utilização e rápida colocação.
- Anilla oval de plástico de fácil utilización y rápida colocación.

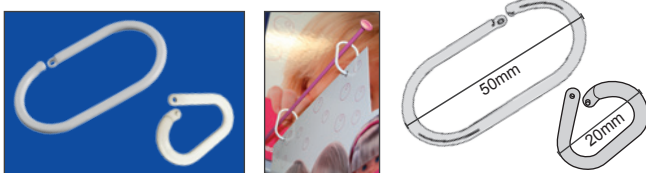

12.380 50mm x100

12.158 20mm x200

Nylon Line

- Nylonfaden 0,5mm, Rolle 5m.
- Blue nylon line, wire diameter : 0.5mm. 5m per roll.
- Fil de nylon, de diamètre 0.5mm / Mesure: 5m par rouleau.
- Fio de nylon com 0.5mm de diâmetro. Medida: 5m/rolo.
- Hilo de Nylon, diámetro 0.5mm. Medida 5m/rollo.

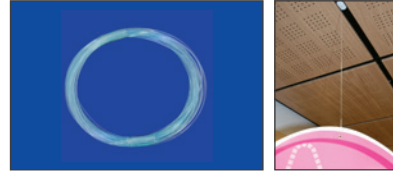

12.373 5m x50

Metal Ring

- Metallring, in verschiedenen Durchmessern verfügbar.
- Metal ring made in different diameters.
- Anneau métallique fabriqué en différents diamètres.
- Anilha metálica de diferentes diâmetros.
- Anilla metálica realizada en diferentes diámetros.



12.160 Ø 19mm x100

12.161 Ø 25mm x100

12.162 Ø 32mm x100

12.163 Ø 38mm x100

Round Pop-Ring

- Kunststoffring zur schnellen und einfachen Aufhängung.
- White plastic ring for connecting sets of signs.
- Anneau rond de plastique, facile d'utilisation.
- Anilha redonda de plástico de fácil utilização.
- Anilla redonda de plástico de fácil utilización.

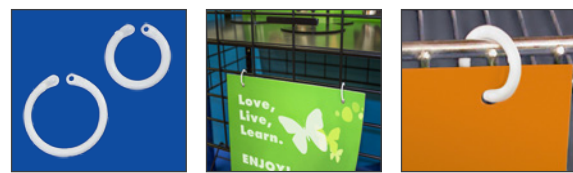

12.159 Ø 15mm x500

12.304 Ø 23mm x100

Hanging Clip

 Hänge-Clips aus Stahl oder Kunststoff.

 Hanging clips. Plastic or metal.

 Pince en acier ou plastique.

 Pinça de plástico ou aço.

 Pinza tipo clip para colgar cartelería, fabricada en plástico o metal.

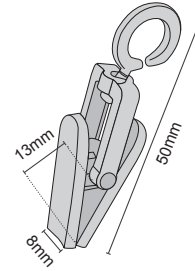
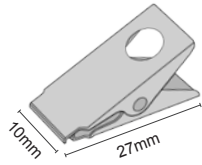

12.164 10x27mm

x100 

12.374  clear 50mm

x100 

12.375  50mm

x100 

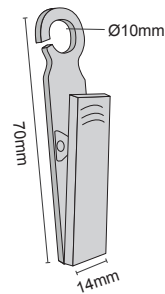
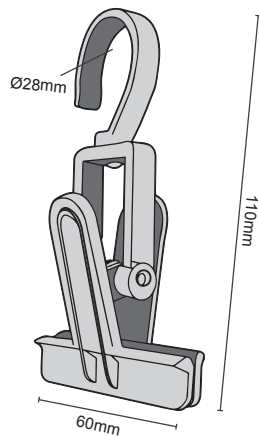

12.475 110mm

x50 



12.476 

12.477  70mm

x50 



Mini Magnetic Hook Hanger



Germany Magnet rund mit Haken.

UK Mini magnetic hook hanger. Material: Plastic.

France Aimant circulaire avec crochet ouvert.

Spain Iman circular com gancho aberto.

Spain Imán circular con gancho abierto.

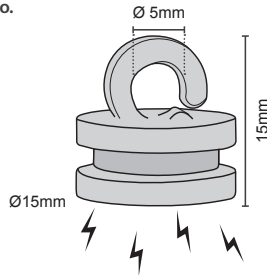
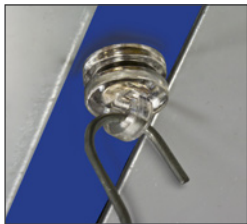

12.386 Ø 15mm x50

Mini Magnetic Ring Hanger



Germany Magnet rund mit Aufhäng-Öse.

UK Mini magnetic ring hanger. Material: Plastic.

France Aimant avec crochet fermé.

Spain Iman com gancho fechado.

Spain Imán circular con gancho cerrado.

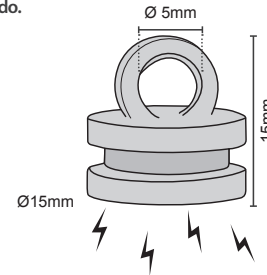
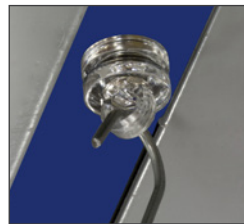

12.385 Ø 15mm x50

Magnet Square



Germany Magnet quadratisch mit Aufhänge-Öse.

UK Magnet square ceiling hook. Material: Plastic.

France Aimant carré avec crochet fermé.

Spain Iman quadrado com gancho fechado.

Spain Imán cuadrado con gancho cerrado.

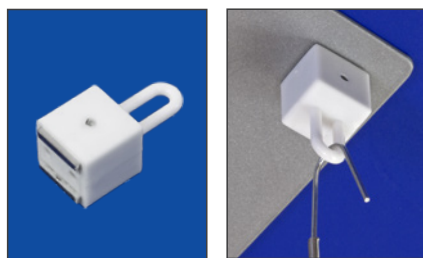
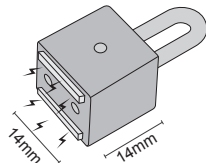

12.165 14x14mm x50

Magnet Rectangle



Germany Magnet rechteckig mit Aufhänge-Öse.

UK Magnet rectangle ceiling hook. Material: Steel.

France Aimant rectangulaire avec crochet fermé.

Spain Iman quadrado com gancho fechado.

Spain Imán rectangular con gancho cerrado.

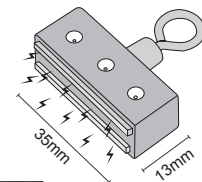

12.166 35x13mm x50

Square Magnet Hooks



Germany Magnet quadratisch mit Haken.

UK Square magnet hooks.

France Aimant rectangulaire avec crochet fermé.



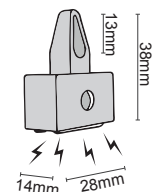
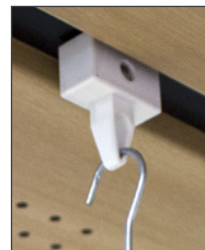

Spain Gancho cuadrado magnético.

Spain Gancho cuadrado magnético.



12.478 28x14x38mm x25



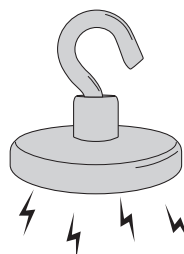

Round Magnetic

-  Magnet rund mit Haken.
-  Magnetic ceiling hook. Material: Steel.
-  Aimant circulaire avec crochet ouvert.
-  Iman circular com gancho aberto.
-  Imán circular con gancho abierto.



12.167	Ø 25mm	x50 	
12.347	Ø 32mm	x50 	
12.348	Ø 40mm	x50 	
12.349	Ø 50mm	x50 	
12.350	Ø 63mm	x50 	

Neodymium Ceiling Hook Ø24mm

-  Neodym-Magnet-Deckenhaken.
Durchmesser: 24 mm aus Stahl.
-  Neodymium magnet hook. Ø24mm. Steel.
-  Aimant rond de Ø24mm avec crochet ouvert. Fabriqué en acier.
-  Gancho magnético de neodímio. Ø24mm. Aço.
-  Gancho magnético de Neodímio. Ø24mm. Acero.

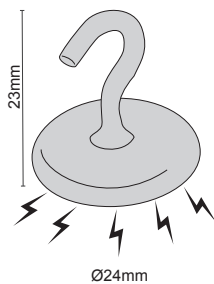

80403001	x50 	
----------	---	--

Round Magnet Discs Adhesive

-  Selbstklebende Magnetplatten, rund.
-  Magnetic disk having an adhesive face.
-  Disques magnétiques avec une face adhésive.
-  Discos magnéticos com uma face adesiva.
-  Discos magnéticos, con una cara autoadhesiva.

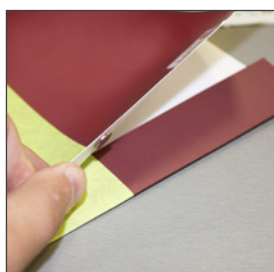
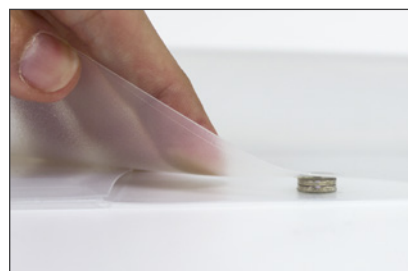

12.479	Ø9,5x0,75mm	x50 	
12.480	Ø9,5x1,5mm	x50 	
12.481	Ø8x0,75mm	x50 	
12.482	Ø8x1,5mm	x50 	

Pegboard

- Hergestellt aus widerstandsfähigem Kunststoff. Garantiert eine übersichtliche Warenpräsentation. Ideal für Waren in Blister.
- Made of rigid, durable plastic; ideal for mounting displays, furniture, PLV, etc., ensuring optimal and ordered presentation of the items.
- Fabriqué en plastique rigide et résistant; idéal pour le montage de display, meubles, plv, etc., garantissant une présentation des articles ordonnée et optimale.
- Fabricados em plástico rígido e resistente, são ideais para a montagem de displays, móveis, PVC, etc., garantindo uma ótima e ordenada apresentação dos artigos.
- Fabricados en plástico rígido y resistente; ideales para el montaje de displays, muebles, PLV, etc., garantizando una óptima y ordenada presentación de los artículos.

Double Prong Pegboard

- Lochblech-Doppelhaken. Verfügbar in 3 verschiedenen Längen.
- Double prong pegboard. Three different sizes are available. Material: Plastic.
- Broche double, pour la fixation sur fond perforé. Disponible en 3 dimensions.
- Gancho duplo para colocar em estruturas perfuradas. Disponível em três medidas.
- Gancho doble para la colocación en fondos perforados. Disponibles en 3 medidas.

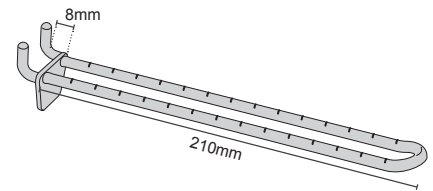
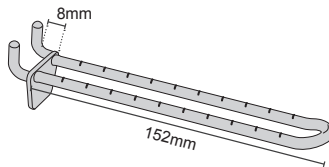
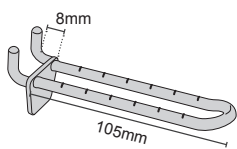
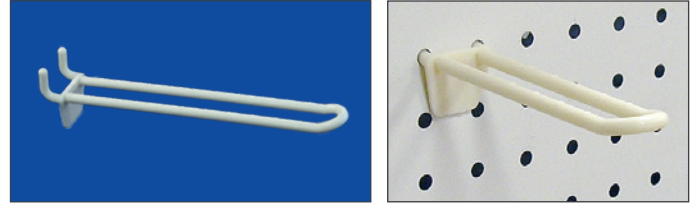

12.252 105mm x50

12.253 152mm x50

12.254 210mm x50

Long Single Prong Pegboard

- Lochblech-Einfachhaken. Verfügbar in 3 verschiedenen Längen.
- Single Hook for placement in perforated funds. Available in 3 sizes.
- Broche simple pour la fixation sur fond perforé. Disponible en 3 dimensions.
- Gancho simples para colocar em estruturas perfuradas. Disponível em 3 medidas.
- Gancho simple para la colocación en fondos perforados. Disponible en 3 medidas.

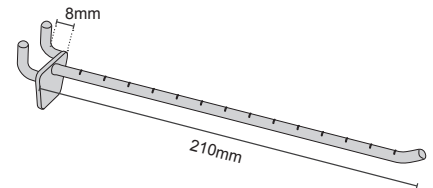
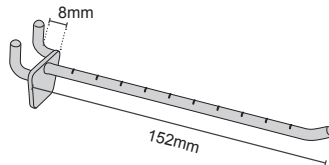
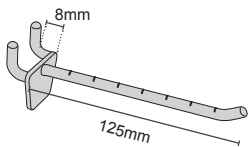
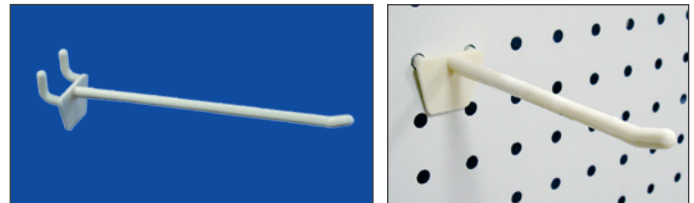

12.255 125mm x50

12.256 152mm x50

12.257 210mm x50

Double Prong Quick-Stick

- Doppelhaken zur Befestigung an Pappwänden oder Displays aus Karton. Verfügbar in 3 verschiedenen Längen.
- Double hook to nail directly on the cardboard. Available in 3 sizes.
- Broche double pour fixer directement sur le carton. Disponible en 3 dimensions.
- Gancho duplo para fixar directamente ao cartão. Disponível em 3 medidas.
- Gancho doble para clavar directamente sobre el cartón. Disponible en 3 medidas.

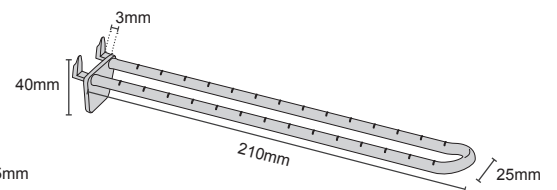
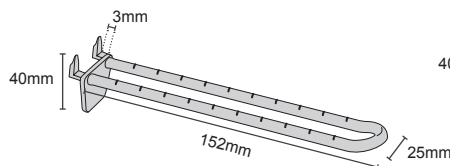
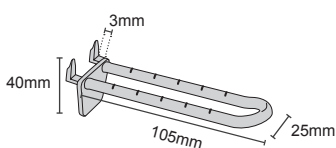
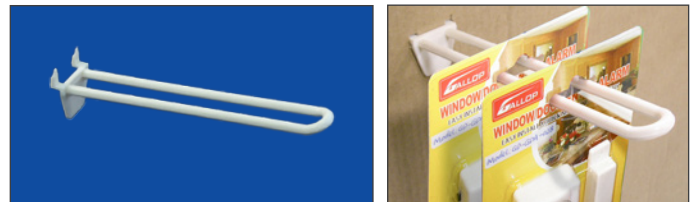

12.258 105mm x50

12.259 152mm x50

12.260 210mm x50

Single Prong Quick-Stick

Einzelhaken zur Befestigung an Pappwänden oder Displays aus Karton. Verfügbar in 6 verschiedenen Längen.

Single Hook nail directly on the cardboard. Available in 6 sizes.

Broche simple pour fixer directement au carton. Disponible en 6 dimensions.

Gancho simples para fixar directamente ao cartão. Disponível em 6 medidas.

Gancho simple para clavar directamente sobre el cartón. Disponible en 6 medidas.

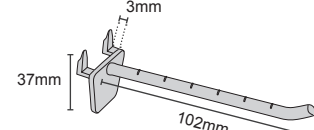
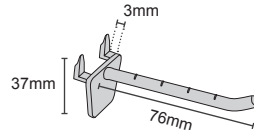
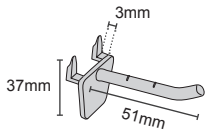

12.261 51mm x50

12.262 76mm x50

12.263 102mm x50

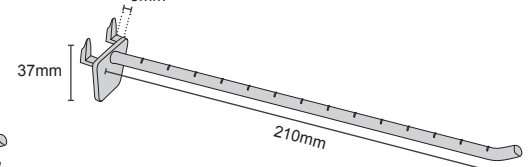
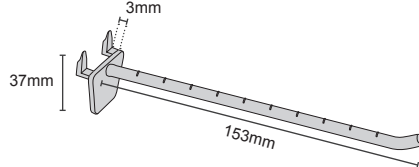
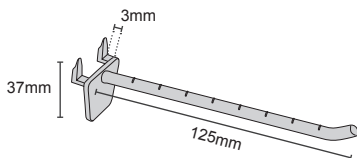

12.264 125mm x50

12.265 153mm x50

12.266 210mm x50

Single Hook

Einzelhaken aus Kunststoff.

Simple plastic hook.

Broche simple pour fixation directe au carton.

Gancho simples de plástico.

Gancho simple de plástico.

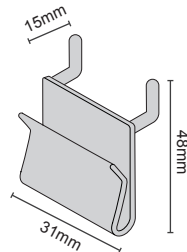

12.483 31x48mm x50

Insert Pegboard Flat

Doppelhaken durchgehend, mit doppelter Halterung. Zur Befestigung an Pappwänden oder Displays aus Karton. Verfügbar in 3 verschiedenen Längen.

Insert pegboard flat. Three different sizes are available. Material: Plastic.

Broche large pour la fixation sur display de carton. Disponible en 3 dimensions.

Gancho de pá larga para colocar em displays de cartão. Disponível em 3 medidas.

Gancho de pala ancha para colocar en displays de cartón. Disponible en 3 medidas.

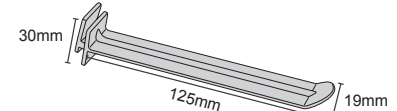
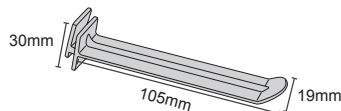
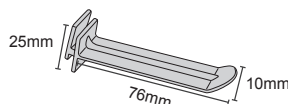

12.269 76mm x50

12.270 105mm x50

12.271 125mm x50

Insert Pegboard

🇩🇪 Einfachhaken zur Befestigung an Pappwänden oder Displays aus Karton. Verfügbar in 5 verschiedenen Längen.

🇬🇧 Single Hook nail directly on the cardboard. Available in 5 sizes.

🇫🇷 Broche simple pour fixer directement au carton. Disponible en 5 dimensions.

🇵🇹 Gancho simples para fixar directamente ao cartão. Disponível em 5 medidas.

🇪🇸 Gancho simple para clavar directamente sobre el carton. Disponible en 5 medidas.

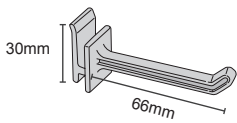
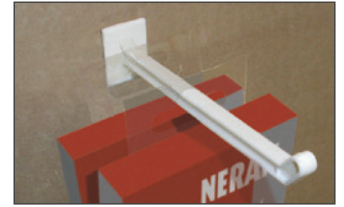

12.272 66mm x50

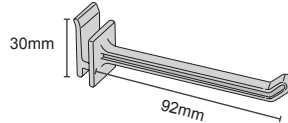

12.273 92mm x50

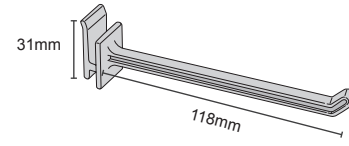

12.274 118mm x50

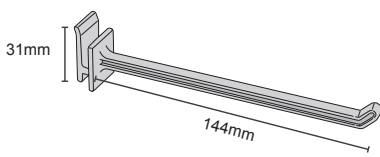

12.275 144mm x50

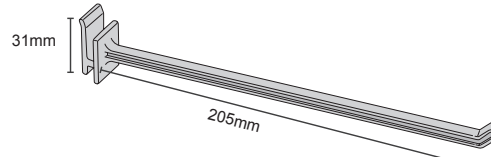

12.276 205mm x50

Double Hook

🇩🇪 Einfachhaken mit Etikthalter zur Befestigung an Pappwänden oder Displays aus Karton.

🇬🇧 Insert pegboard double hook with price holder. Material: Plastic.

🇫🇷 Broche pour carton avec porte étiquette.

🇵🇹 Gancho para cartão com portapreços incorporado.

🇪🇸 Gancho para cartón con portaprecios incorporado.

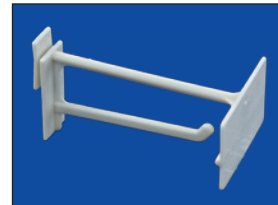
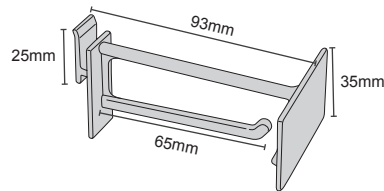

12.112 65mm x50

Pegboard for Slat Wall

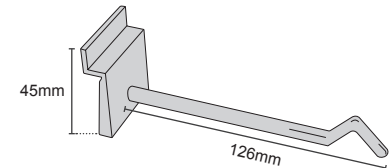
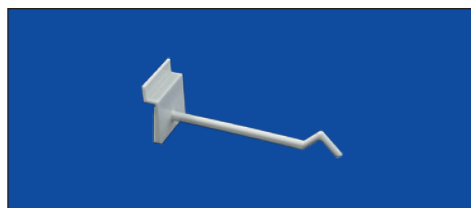

12.111 126mm x50

Insert Pegboard

🇩🇪 Einfachhaken zur Befestigung an Pappwänden oder Displays aus Karton. Verfügbar in 2 verschiedenen Längen.

🇬🇧 Simple Hook for cardboard stand. Available in 2 sizes.

🇫🇷 Broche simple pour support de carton. Disponible en 2 dimensions.

🇵🇹 Gancho simples para suporte de cartão. Disponível em duas medidas.

🇪🇸 Gancho simple para soporte de cartón. Disponible en 2 medidas.

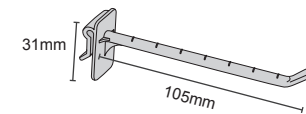
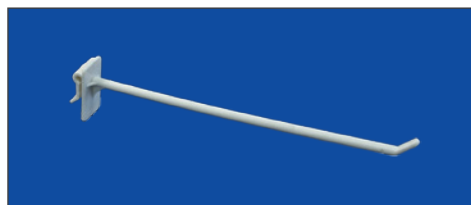

12.267 105mm x50

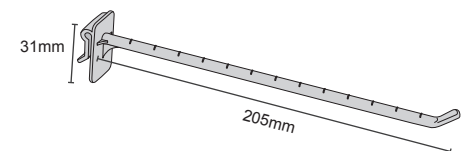

12.268 205mm x50

Power Wing

Klemmhaken zur Befestigung von Werbeträgern oder Produkten an Gitterwänden. Verfügbar in 2 verschiedenen Größen.

Power wing. White PVC clip fastens corrugated displays for cardboard, wire, glass, etc. Available in 2 different sizes. Material: Plastic.

Crochet clip pour baguette, idéal pour la fixation de supports publicitaires ou de produits sur panneau grillagé.

Gancho clip para vareta, ideal para colocar suportes publicitários ou produtos em painéis com grade. Disponível em duas medidas.

Gancho clip para varilla, ideal para la colocación de soportes publicitarios o productos en paneles de rejilla. Disponible en 2 medidas.

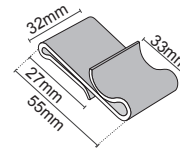

12.277 55x32mm x50

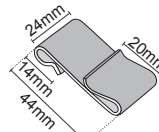
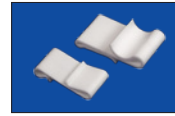

12.278 44x24mm x50

Stock Limiter

Abstandshalter für Lochblech-Haken.

Goods limiter to adjust the stock of products on the hooks.

Limiteur de marchandise pour ajuster le stock des produits sur les broches.

Limitadores de mercadorias para ajustar o stock dos produtos nos ganchos.

Limitadores de mercancía para ajustar el stock de productos en los ganchos.

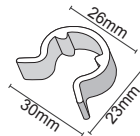

12.281 Double 26mm x50

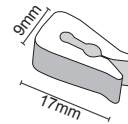

12.282 Simple 17mm x50

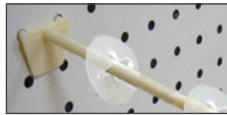

Ø 26mm

12.280 Ø 26mm x50

Plastic Display Caster

Kunststofffüße für Bodendisplays. Verhindert Verschmutzung und schnelle Abnutzung der Grafikkanten, durch die Vermeidung von Bodenkontakt.

Used for reinforcing and elevating in order to avoid contact with the ground.

Pieds de plastique pour le renfort de display en carton. Èlève le display de carton pour éviter le contact avec le sol.

Pé de plástico para reforçar os displays de cartão. Eleva os displays de cartão para evitar o contacto com o chão.

Patas de plástico para el refuerzo de los displays de cartón. Elevan el display de cartón para evitar el contacto con el suelo.

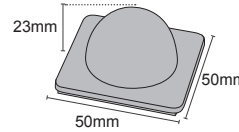

12.287 Adhesive x50

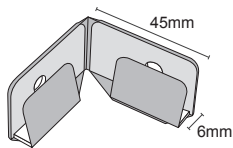

12.286 Simple x50

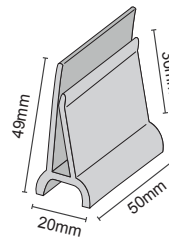

12.518 x50

Magic Tape

Selbstklebender Klettverschluss.

Adhesive Velcro coins. Male or female.

Rouleau de boutons, en velcro adhésif, mâle ou femelle.

Botões de velcro com adesivo. Macho ou fêmea.

Botones adhesivos de velcro. Macho o hembra.

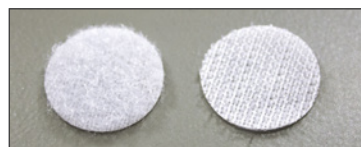

12.505 ♂ Ø10mm

12.506 ♀ Ø10mm x1000

12.507 ♂ Ø20mm

12.508 ♀ Ø20mm x1000

12.509 ♂ Ø25mm

12.510 ♀ Ø25mm x1000



Corrugated Display

Snap Rivet

🇩🇪 Druck-Öse zur Befestigung und Aufhängung von Schildern und Displays.

🇬🇧 Bolt and nut made of plastic for fixing signage.

🇫🇷 Vis et écrou réalisés en plastique pour la fixation de l'affichage.

🇵🇹 Parafuso e porca de nylon com diferentes tamanhos.

🇪🇸 Tornillo y tuerca realizados en plástico para fijación de cartelaria.

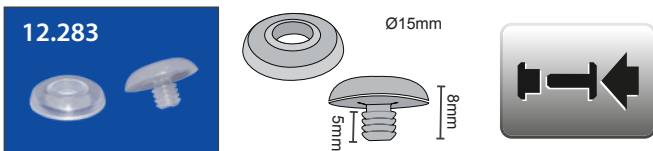

12.283 Ø15mm x50

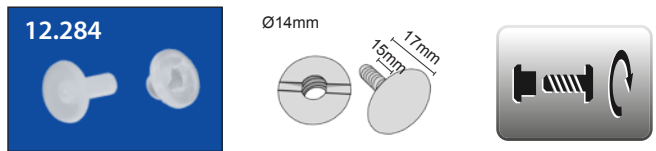

12.284 Ø14mm x50

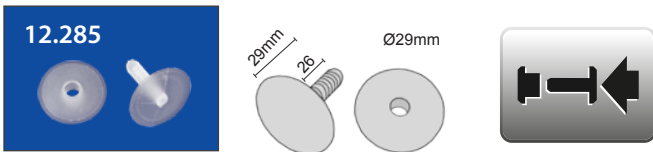

12.285 Ø29mm x50

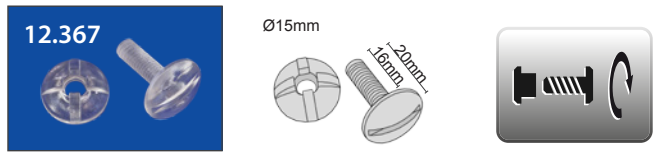

12.367 Ø15mm x50

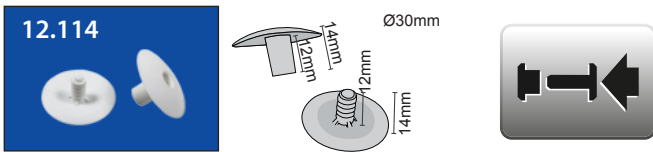

12.114 Ø30mm x50

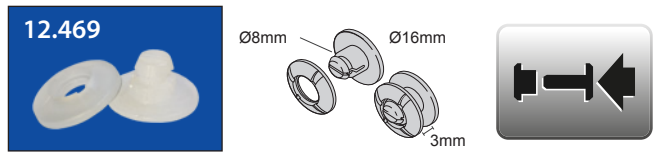

12.469 Ø16mm x100

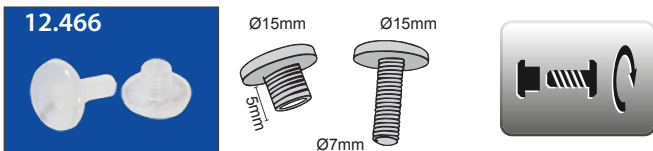

12.466 Ø15x8mm x100

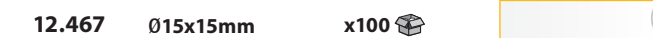

12.467 Ø15x15mm x100



12.468 Ø15x20mm x100

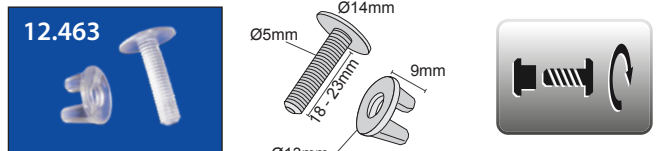

12.463 Ø14x18mm x100



12.464 Ø14x23mm x100



Cardboard Holders

Zwei ineinander greifende Elemente zur Unterstützung der Fachböden in Karton-Displays.

Two interlocking shelves for supporting parts on cardboard displays.

Equerre pour étagères en carton.

Conjunto de duas peças que se interligam para sustentar prateleiras de cartão.

Dos piezas ensamblables para el soporte de baldas en expositores de cartón.

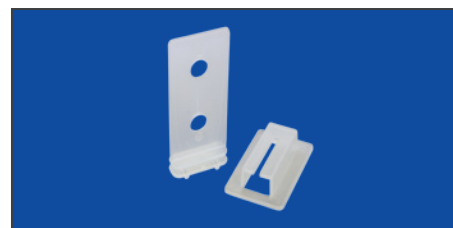
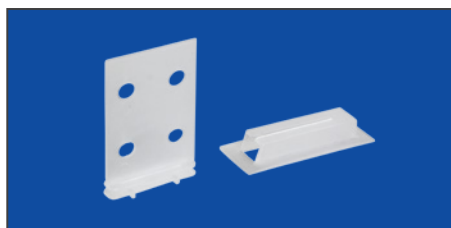
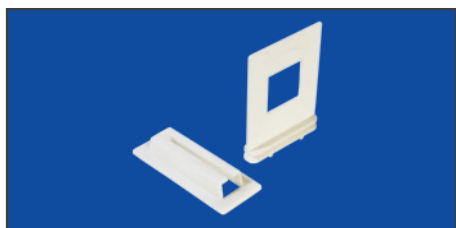
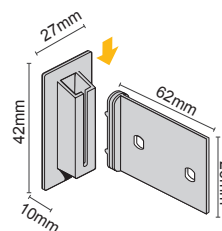
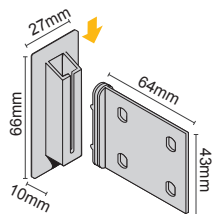
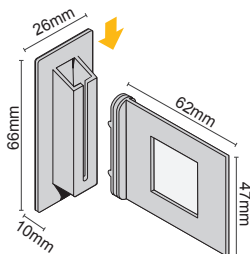
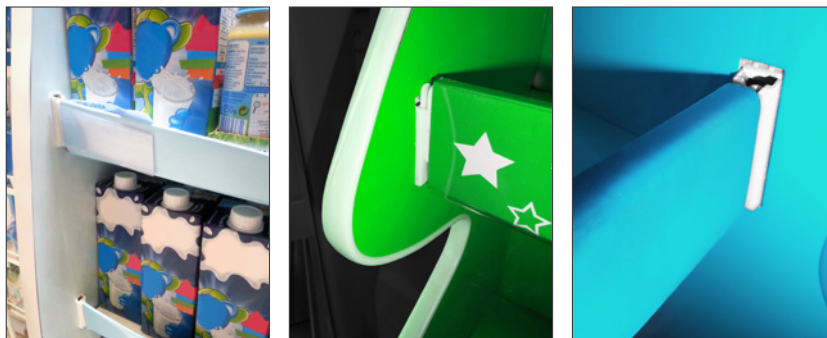

12.515

x50

12.516

x50

12.517

x50

Corrugated Bracket Clip

Transparente PVC-Clips zum Halten von Grafiken und Regalen.

Transparent PVC clip designed for holding graphics and shelves.

Support en pvc transparent pour fixation d'images et d'étagères.

Suporte de PVC para a fixação de imagens e prateleiras.

Clip transparente de PVC para soporte de gráficas y baldas.

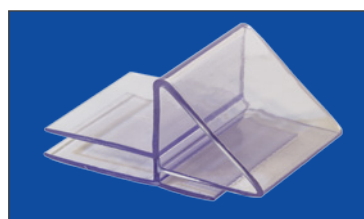
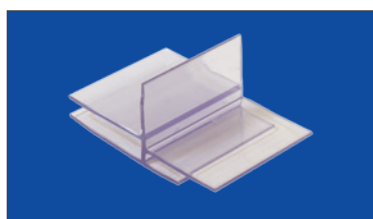
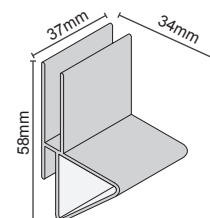
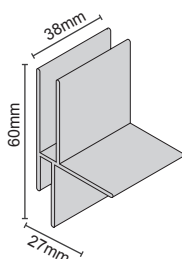





12.514

x50

12.513

x50



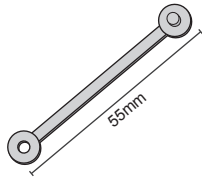

Plastic Clasp

-  Aufhänger aus Kunststoff, Länge 55mm.
-  Plastic clasp. Length 55mm.
-  Boucle en plastique 55mm.
-  Abraçadeira de plástico com 55mm.
-  Navete de plástico 55mm.



12.376 55mm x100 

Loop Pins



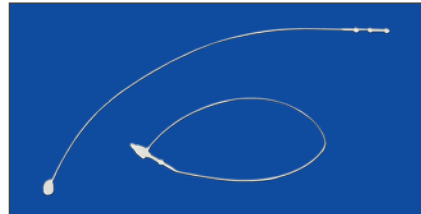
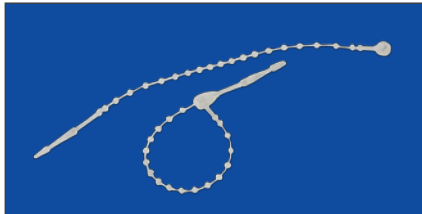

-  Kunststoff-Sicherheitsetiketten.
-  Plastic Snap Tag pin loop.
-  Boucle en plastique pour l'étiquetage des produits.
-  Cordão de plástico para etiquetar.
-  Navete de plástico para etiquetar productos.



12.492	3" (7,64mm)	x1000 	
12.493	4" (10,19mm)	x1000 	
12.494	5" (12,73mm)	x1000 	
12.495	6" (15,28mm)	x1000 	
12.496	7" (17,82mm)	x1000 	

12.497	3" (7,64mm)	x1000 	
12.498	4" (10,19mm)	x1000 	
12.499	5" (12,73mm)	x1000 	
12.500	6" (15,28mm)	x1000 	
12.501	7" (17,82mm)	x1000 	



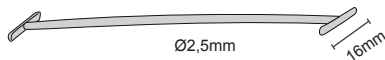
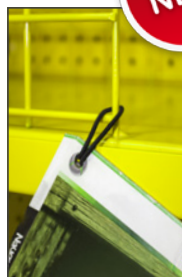

Elastic Cord

-  Elastische Kordel mit Metallende.
-  Loop cord with metal end. Fabric and metal.
-  Cordon élastique avec embouts en métal.
-  Cordão elástico com ponta metálica.
-  Cordón Elástico. Con punta de metal.



12.502	Ø2,5x100mm	x100 	
12.503	Ø2,5x150mm	x100 	
12.504	Ø2,5x200mm	x100 	

Ball Chain

-  Kugeldette. Kugeldurchmesser 2,4 mm.
-  Ball chain. Ball diameter 2,4mm.
-  Chaîne de 2,4mm de diamètre avec fermoir.
-  Cordão metálico. Diâmetro da bola 2,4mm.
-  Navete metálico. Diámetro de bola 2,4mm.

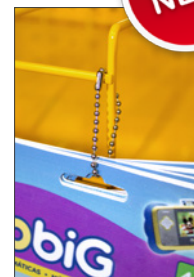

12.489	Ø2,4x100mm	x50 	
12.490	Ø2,4x500mm	x50 	
12.491	Ø2,4x1000mm	x50 	

Hang Tab

Selbstklebende Euroloch-Aufhänger zur Warenaufhängung oder Reparatur von Blister.

Hangtab are quick and easy to use for merchandising products. Material: Plastic.

Etiquettes adhésives permettant la mise en place ou la réparation de produit en blister. Facile et rapide d'utilisation.

Etiquetas adhesivas, para colocar o reparar o producto nas embalagens. Fácil e rápidas de usar.

Etiquetas adhesivas, para colocar o reparar producto en blister. Fácil y rápidas de usar.

Hang Tab Euroslot

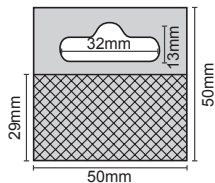

Empfohlenes Display Gewicht: 450g / Recommended display weight: 450g
Poids conseillé: 450g / Peso recomendado: 450g / Peso recomendado: 450g.

12.357 x100

Hang Tab Standard

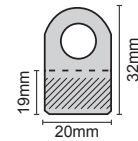

Empfohlenes Display Gewicht: 110g / Recommended display weight: 110g
Poids conseillé: 110g / Peso recomendado: 110g / Peso recomendado: 110g.

12.358 x100

Hang Tab Flexi

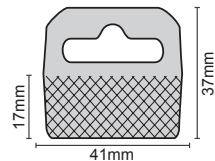

Empfohlenes Display Gewicht: 230g / Recommended display weight: 230g
Poids conseillé: 230g / Peso recomendado: 230g / Peso recomendado: 230g.

12.359 x100

Hang Tab Hooks

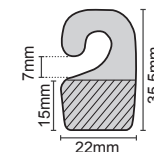
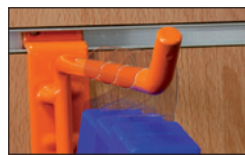

Empfohlenes Display Gewicht: 120g / Recommended display weight: 120g
Poids conseillé: 120g / Peso recomendado: 120g / Peso recomendado: 120g.

12.360 x100

Hang Tab Easy

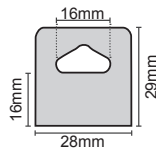

Empfohlenes Display Gewicht: 185g / Recommended display weight: 185g
Poids conseillé: 185g / Peso recomendado: 185g / Peso recomendado: 185g.

12.361 x100

Hang Tab Nova

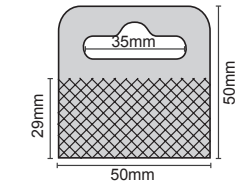

Empfohlenes Display Gewicht: 400g / Recommended display weight: 400g
Poids conseillé: 400g / Peso recomendado: 400g / Peso recomendado: 400g.

12.362 x100

Hang Tab Folding

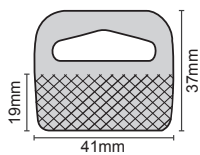
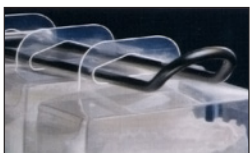

Empfohlenes Display Gewicht: 230g / Recommended display weight: 230g
Poids conseillé: 230g / Peso recomendado: 230g / Peso recomendado: 230g.

12.363 x100

Hang Tab Quick

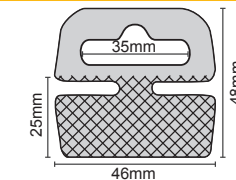

Empfohlenes Display Gewicht: 400g / Recommended display weight: 400g
Poids conseillé: 400g / Peso recomendado: 400g / Peso recomendado: 400g.

12.364 x100

Hang Tab Use

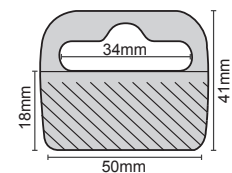

Empfohlenes Display Gewicht: 400g / Recommended display weight: 400g
Poids conseillé: 400g / Peso recomendado: 400g / Peso recomendado: 400g.



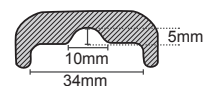
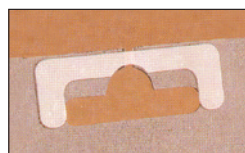

12.365 x100

Hang Tab Repair







12.366 x100

Suction Cup

-  Saugnapfsysteme zur Befestigung von Werbeträgern. Ideal für Glas- oder glatte Oberflächen.
-  Suction Cup for the placement of advertising messages at the point of sale. Ideal for glass or smooth surfaces.
-  Système de ventouses pour la fixation de publicité et messages sur lieu de vente. Idéal pour le verre ou les surfaces lisses.
-  Ventosa de plástico fácil e simples de usar em vidro ou superfícies lisas.
-  Sistemas de ventosas para la colocación de publicidad y mensajes en el punto de venta. Ideal para vidrio o superficies lisas.



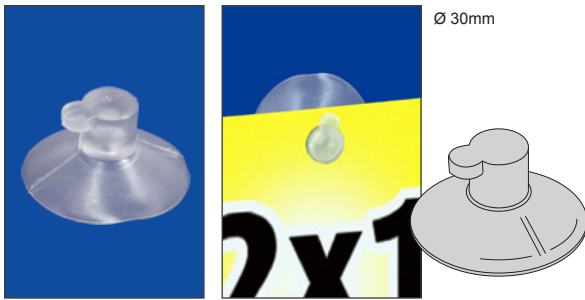

Suction Cup with Nipple

-  Haftsauger mit Kopf zur Befestigung von Grafiken.
-  Suction cup with plastic stopper that is inserted directly in the graphic
-  Ventouse avec butoir de plastique, qui s'insère directement dans le visuel.
-  Ventosa com ponta que se coloca directamente na impressão.
-  Ventosa con tope de plástico que se inserta directamente en la gráfica.



12.168 Ø 30mm x100 



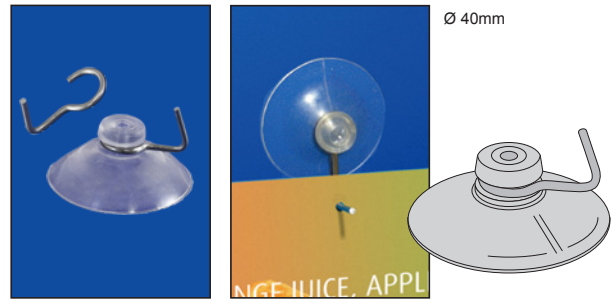

Suction Cup Metal Hook

-  Haftsauger mit Drahhaken. Ideal zur Befestigung von Schildern auf Glasflächen.
-  Suction cup with metal hook at the end. Ideal for hanging posters on glass, flat surface.
-  Ventouse avec crochet métallique à l'extrémité. Idéal pour accrocher des affiches sur le verre.
-  Ventosa com gancho metálico no extremo. Ideal para pendurar cartazes em vidro.
-  Ventosa con gancho metálico en el extremo. Ideal para colgar carteles sobre vidrio.



12.169 Ø 40mm x100 





Double Suction Cup with Plastic Hook

-  Doppelt-Haftsauger mit drehbarem Aufhängehaken zur Befestigung von Grafiken in gewünschter Position.
-  Double suction cup with plastic hook. For extra strong adhesion, with a 3 position hook (left, right, ahead).
-  Ventouse double avec crochet tournant, peut être placé dans n'importe quelle position pour une meilleure disposition de la publicité.
-  Ventosa dupla com gancho que pode ser colocado em qualquer posição para uma melhor exposição da publicidade.
-  Ventosa doble con gancho giratorio, puede ser colocado en cualquier posición para una mejor disposición de la publicidad.



12.172 Ø 45mm x100 

Suction Cup Thumbback Plastic

-  Haftsauger mit Kunststoffdorn.
-  Suction cup with screw.
-  Ventouse avec punaise.
-  Ventosa com parafuso.
-  Ventosa con tornillo.

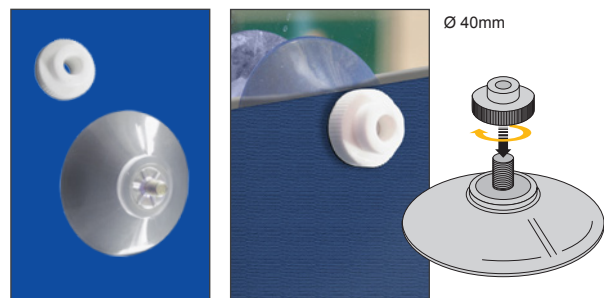

12.388 Ø 40mm x100 

Suction Cup Thumbtack Plastic

Haftsauger mit Kunststoffdorn zur Befestigung von Grafiken. Ideal zur Befestigung von Schildern auf Glasflächen.

Suction cup sign holder with plastic thumbtack. It has a plastic pin advertising to hold the cup.

Ventouse avec punaise. Possède une punaise de plastique pour fixer la publicité à la ventouse.

Ventosa com tacha que permite bloquear a impressão. Para um uso em superfícies suaves e planas.

Ventosa con chincheta. Posee una chincheta de plástico para sujetar la publicidad a la ventosa.

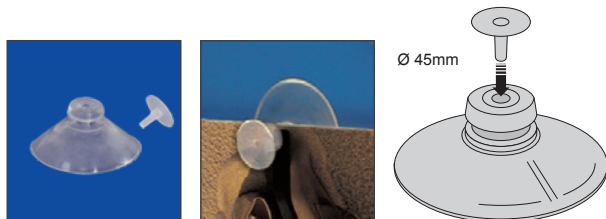

12.170 Ø 45mm x100

Double Suction Cup Thumbtack Plastic

Doppelt-Haftsauger mit Kunststoffdorn zur Befestigung von Grafiken. Ideal zur Befestigung von Schildern auf Glasflächen.

Double suction cup holder with plastic thumbtack. For extra strong adhesion with hook.

Ventouse double avec punaise. Possède une double ventouse pour une meilleure fixation.

Ventosa dupla com gancho metálico. Permite uma fixação extra.

Ventosa doble con chincheta. Posee doble ventosa para una mayor sujeción.

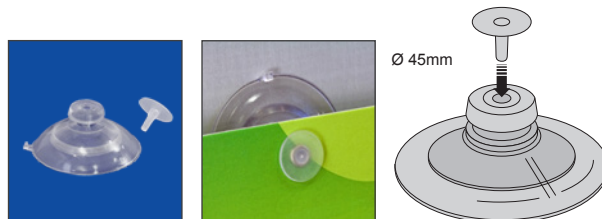

12.171 Ø 45mm x100

Double Suction Cup

Doppelt-Haftsaugnapf.

Double suction cup.

Ventouse double.

Ventosa dupla.

Ventosa doble.

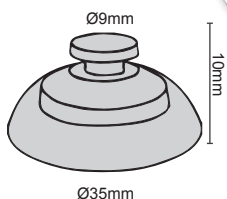

12.472 Ø35mm x100

Double-Sided Suction Cup

Doppelt-Haftsaugnapf.

Double-sided suction cup.

Ventouse double, double face.

Ventosa dupla e dupla face.

Ventosa doble, a doble cara.

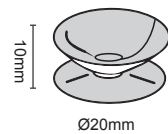

12.470 20mm x100

12.471 30mm x100

Suction Cup Sign Holder

Saugnapf mit waagerechtem Schilderhalter.

Suction cup sign holder. Material: Plastic.

Ventouse avec Gripper horizontal.

Ventosa com Gripper horizontal.

Ventosa con Gripper horizontal.

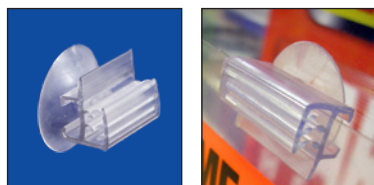
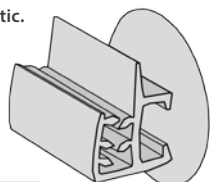

12.200 Ø 25mm x50

Suction Cup Sign Holder

Saugnapf mit vertikalem Schilderhalter.

Suction cup sign holder. Plastic.

Ventouse avec Gripper vertical.

Ventosa com Gripper vertical.

Ventosa con Gripper vertical.

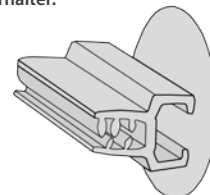





12.201 Ø 25mm x50

12.473 Ø 50mm x100

Grip Strip



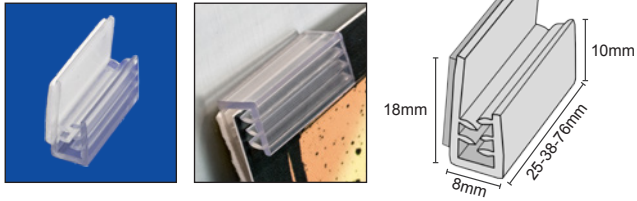

Grip Strip with Adhesive

-  Selbstklebender Schilderhalter. Verfügbar in 3 verschiedenen Größen.
-  Grip adhesive strip. Available in three different sizes.
-  Grip bande avec adhésif. Disponible en 3 dimensions.
-  Grip strip com adesivo. Disponível em três tamanhos diferentes.
-  Grip strip con adhesivo. Disponible en tres tamaños distintos.



12.187	25mm	x200		
12.188	38mm	x200		
12.189	76mm	x100		

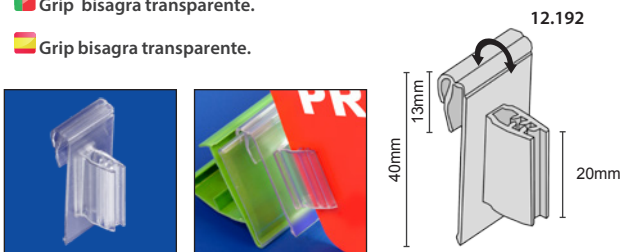

Hinged Data Grip

-  Klappbarer, transparenter Schilderhalter zum Klemmen.
-  Transparent hinge grip.
-  Grip charnière transparente.
-  Grip bisagra transparente.
-  Grip bisagra transparente.



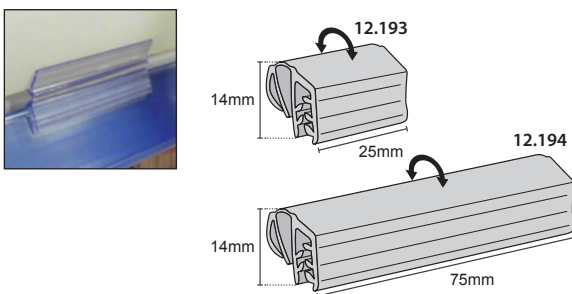
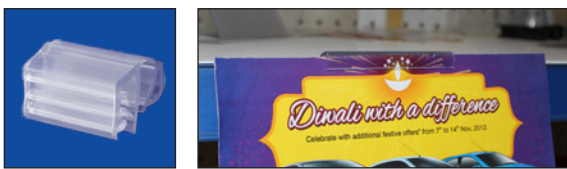



12.192	20x40mm	x100		
--------	---------	------	---	--





12.193	25mm	x200		
12.194	75mm	x100		



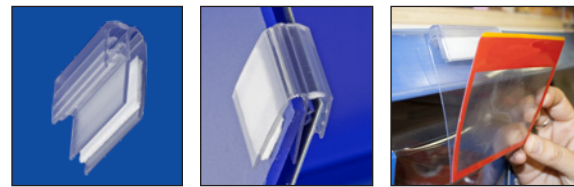
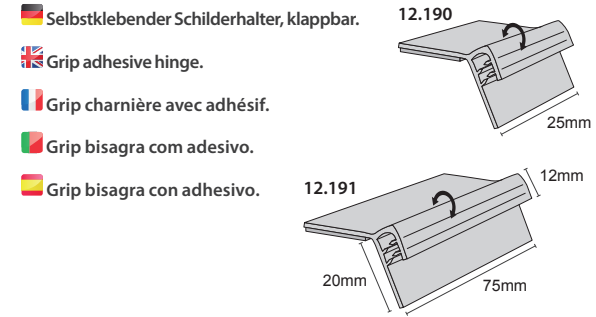

Hinged Flip Strip with Adhesive

-  Selbstklebender Schilderhalter, klappbar.
-  Grip adhesive hinge.
-  Grip charnière avec adhésif.
-  Grip bisagra com adesivo.
-  Grip bisagra con adhesivo.



12.190	25mm	x100		
12.191	75mm	x100		



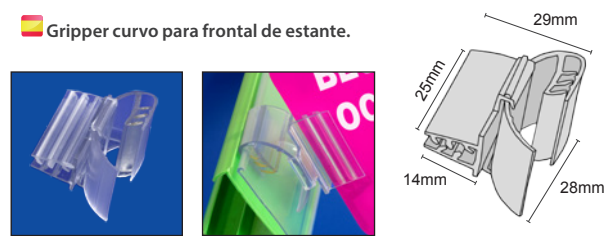

Adjustable Angle Data Clip

-  Geschwungener Schilderhalter zum Klemmen an Regalfront.
-  Gripper for curved front shelf.
-  Gripper courbé frontal d'étagère.
-  Gripper curvo para o frontal de estante.
-  Gripper curvo para frontal de estante.



12.233	28x29mm	x100		
--------	---------	------	---	--

Shelf Edge Poster

-  Schilderhalter zum Klemmen an Regalfront.
-  Shelf edge poster bracket for data strip. Plastic.
-  Gripper stop rayon pour devant d'étagère.
-  Gripper portastopper para a frontal de estantes.
-  Gripper portastopper para frontal de estante.

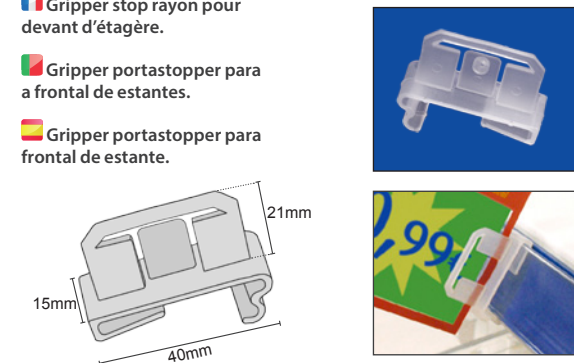

12.071	40x15mm	x100		
--------	---------	------	---	--

Double Gripper

- Doppel-Schilderhalter.
- Double Gripper. Material: Plastic.
- Gripper double.
- Gripper duplo.
- Gripper doble.

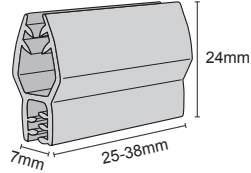
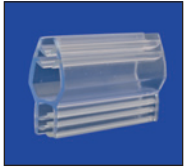

12.369	25mm	x100	<input type="text"/>
12.370	38mm	x100	<input type="text"/>

Data Clip

- Schilderhalter zum Klemmen an Profil.
- Data clip is inserted into the label holder Profiles.
- Grip porte étiquette, s'insère au profil porte étiquette.
- Grip para porta-preços. Coloca-se nos perfis porta-etiquetas.
- Grip para portaprecios, se inserta en los perfiles portaetiquetas.

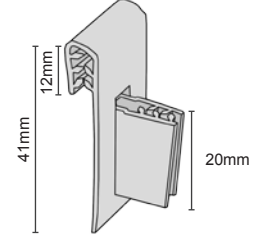

12.195	20mm	x100	<input type="text"/>
--------	------	------	----------------------

Gripper

- Verbindungselement für Schilder.
- Gripper - Gripper for union of posters.
- Gripper pour l'union d'affiches.
- Gripper para união de cartazes.
- Gripper para unión de carteles.

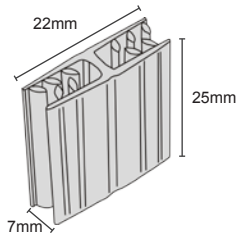
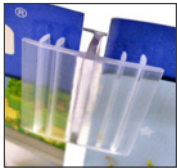
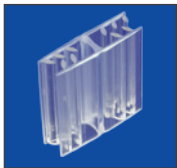

12.197	22x25mm	x100	<input type="text"/>
--------	---------	------	----------------------

2 - Way Gripper (90°)

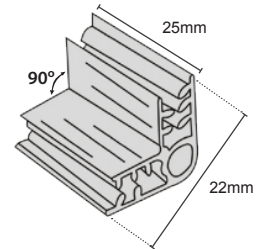
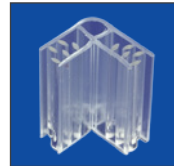

12.198	22x25mm	x50	<input type="text"/>
--------	---------	-----	----------------------

3 - Way Gripper

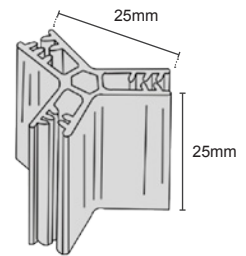

12.372	25x25mm	x50	<input type="text"/>
--------	---------	-----	----------------------

2 - Way Gripper (60°)

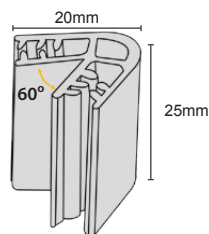
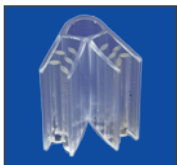



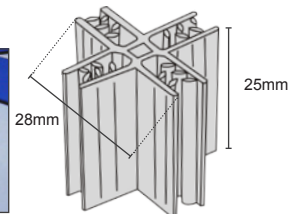
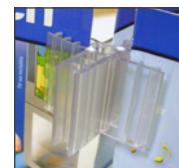
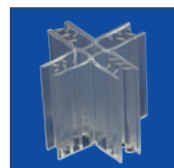

12.371	20x25mm	x100	<input type="text"/>
--------	---------	------	----------------------

4 - Way Gripper



12.199	28x25mm	x50	<input type="text"/>
--------	---------	-----	----------------------



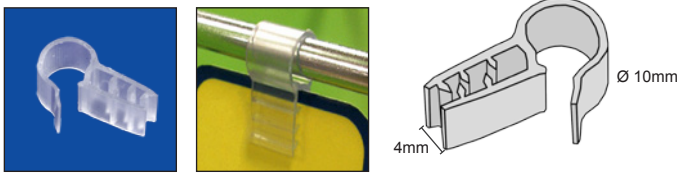

Wire Basket Sign Holder

-  Schilderhalter für Metallstangen und Körbe.
-  Gripper to place on baskets or metal bars.
-  Gripper pour fixer sur des paniers ou des barres métalliques.
-  Gripper para colocar em cestas ou barras metálicas.
-  Gripper para colocar en cestas o barras metálicas.



12.196 15mm x200 



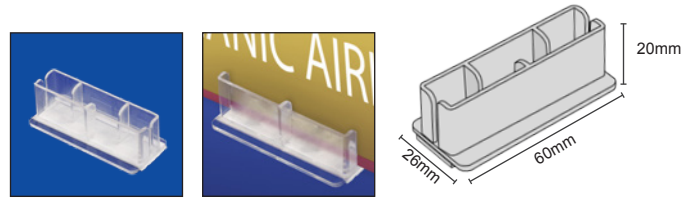

Sign Gripper

-  Schilderhalter mit selbstklebendem Boden.
-  Support for displaying posters with adhesive base.
-  Support pour la fixation d'affiches avec base adhésive.
-  Suporte para colocar cartazes com base adesiva.
-  Soporte para la colocación de carteles con base adhesiva.



12.339 60x20mm x25 

Clear Supergrip Card Holder

-  Selbstklebender Schilderhalter, transparent. Verfügbare Größen: 12mm Breite / 25mm Länge und 25mm Breite/ 75mm Länge.
-  Supergrip clear sign holders; vertical and horizontal use. Available in 12 and 25mm widths, and lengths of 25 and 75mm respectively.
-  Supergrip porte affiche transparent, usage vertical et horizontal. Disponible en 12 ou 25mm de large et 25 ou 75mm de longueur.
-  Supergrip porta-cartazes transparentes para uso vertical e horizontal. Disponíveis em larguras de 12 e 25mm e comprimentos de 25 e 75mm respectivamente.
-  Supergrip portacarteles transparente; uso vertical y horizontal. Disponible en anchos de 12 y 25mm, y largos de 25 y 75mm respectivamente.

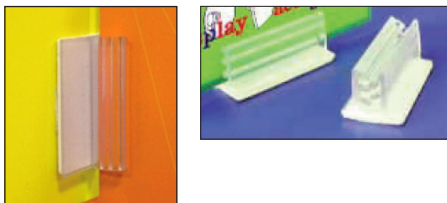
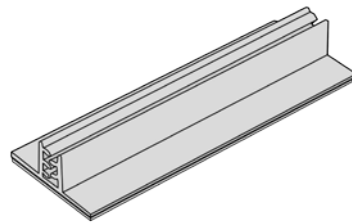
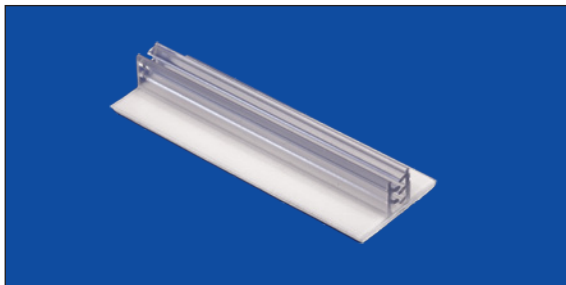





12.183 12x25mm x100 

12.184 12x75mm x50 

12.185 25x25mm x100 

12.186 25x75mm x50 

Single Spring

-  Klappbarer Schilderhalter.
-  Single spring hinge sign holder.
-  Single Grip articulé.
-  Single Grip basculante.
-  Single Grip basculante.

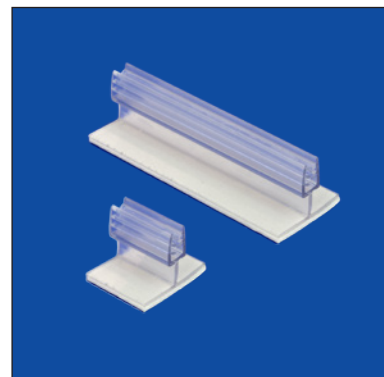
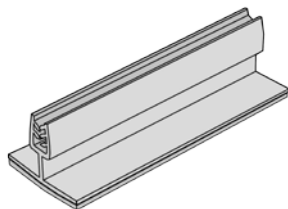

12.382 25mm x100 

12.202 76mm x100 

Master Grip with Adhesive

- 🇩🇪 Selbstklebender Schildhalter extra breit.
- 🇬🇧 Master Grip hinge sign holder with adhesive.
- 🇫🇷 Master Grip avec adhésif.
- 🇵🇹 Master Grip com adesivo.
- 🇪🇸 Master Grip con adhesivo.

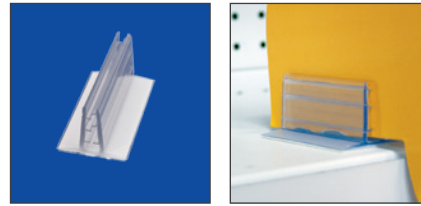
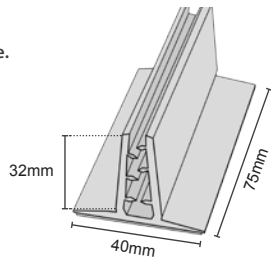

12.346 40x75mm x50

Master Grip with Magnet

- 🇩🇪 Schildhalter mit Magnet.
- 🇬🇧 Master Grip with magnet.
- 🇫🇷 Master Grip magnétique.
- 🇵🇹 Master Grip magnético.
- 🇪🇸 Master Grip magnético.

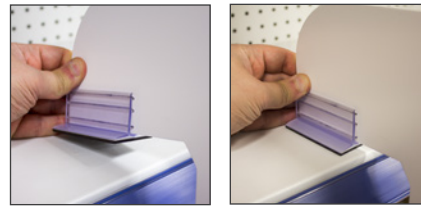
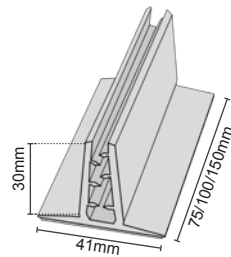

12.455	75mm	x50	
12.456	100mm	x50	
12.457	150mm	x50	

Super Grip with Adhesive

- 🇩🇪 Selbstklebender Schildhalter extra breit.
- 🇬🇧 Super Grip hinge sign holder with adhesive.
- 🇫🇷 Super Grip avec adhésif.
- 🇵🇹 Super Grip com adesivo.
- 🇪🇸 Super Grip con adhesivo.

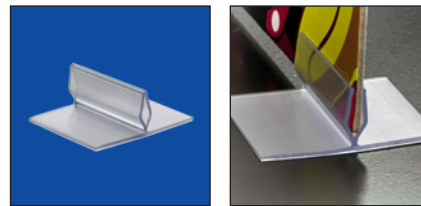
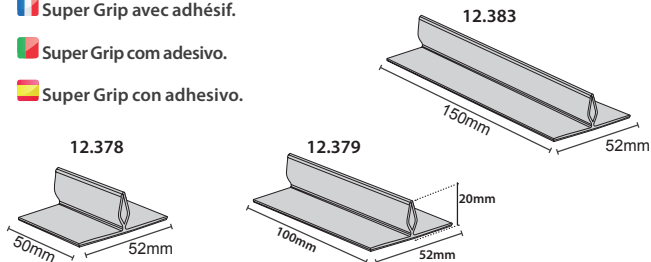

12.378	50mm	x50	
12.379	100mm	x50	
12.383	150mm	x50	

Supergripper Data Strip

- 🇩🇪 Super-Schildhalter für den Einsatz an Regalen.
- 🇬🇧 Super Gripper to be inserted into profiles.
- 🇫🇷 Super gripper pour profiles.
- 🇵🇹 Super Gripper para perfis.
- 🇪🇸 Super Gripper para ser insertado en perfiles.

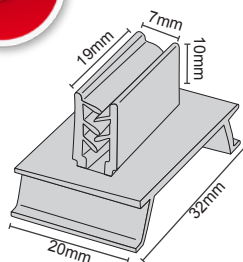

Gripper for Shelf

- 🇩🇪 Schildhalter für Regal.
- 🇬🇧 Gripper for shelf.
- 🇫🇷 Gripper pour profiles.
- 🇵🇹 Gripper para perfis.
- 🇪🇸 Gripper para perfiles.

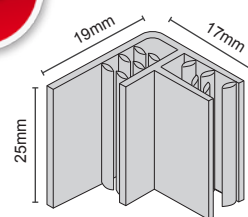



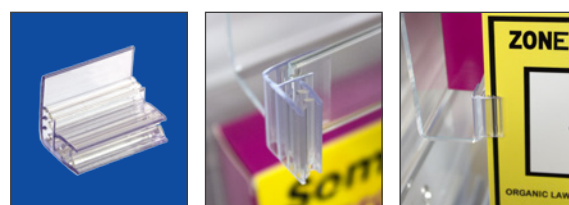

12.452 x100



12.453 x100

Wobblers

-  Verkaufssystem zur Befestigung von Aktionsschildern. Dank ihres bewegenden Effekts, springen die "Wobblers" sofort ins Auge und garantieren somit eine erhöhte Aufmerksamkeit.
-  Systems for advertising placements. The "wobblers" highlight the messages, as it can give oscillating and separation effects. They are ideal for encouraging your PLV.
-  Systèmes pour placer de la publicité. Les "wobblers" font ressortir les messages et créent des effets oscillants et une séparation. Ils sont idéaux pour animer son PLV.
-  Sistemas para colocar publicidade. Os wobblers ressaltam as mensagens porque permitem criar efeitos oscilantes e de separação. São ideais para animar o seu PLV.
-  Sistemas para la colocación de publicidad. Los "wobblers" resaltan los mensajes gracias a que permiten dar efectos oscilantes y de separación. Son ideales para animar su PLV.

Clear Wobbler

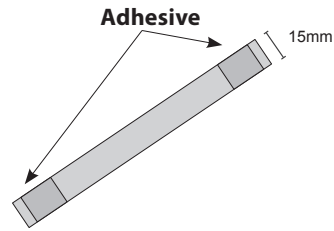
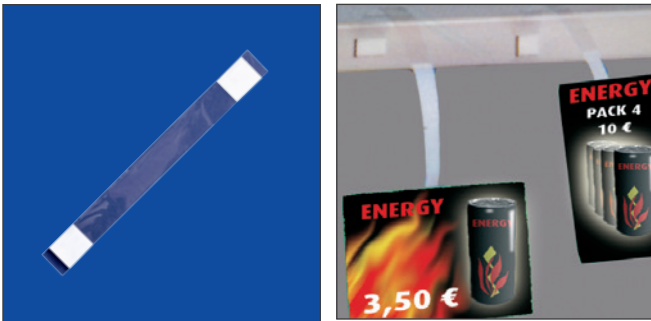

12.203 15x150mm x200 

12.225 15x200mm x200 

Aluminium Wobbler

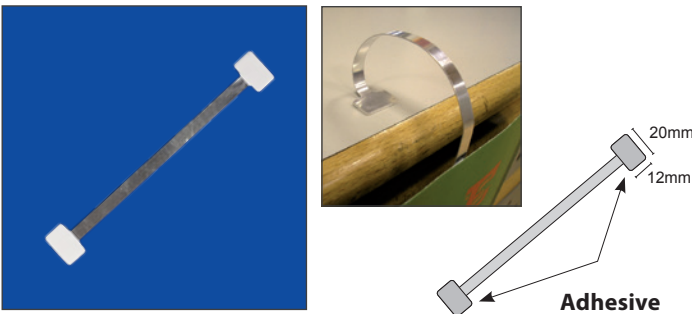



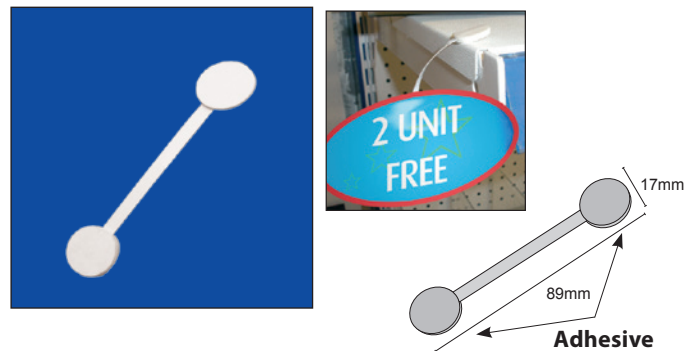

12.204 75mm x100 

12.205 150mm x50 



12.294 89mm x50 





Spring Wobbler

-  Mit Feder und selbstklebenden Enden. Hohe Flexibilität und Widerstandsfähigkeit.
-  Wobbler with 2 adhesives, possesses great flexibility and endurance.
-  Wobbler avec ressort et deux adhésifs. Il possède une grande flexibilité et résistance.
-  Wobbler com mola e dois adesivos, possui grande flexibilidade e resistência.
-  Wobbler con muelle y 2 adhesivos, posee gran flexibilidad y resistencia.



12.206 20x20x40mm x100 

Wobbler "Spacer"

-  Wobbler "Spacer". Selbstklebend. Material: Kunststoff.
-  Wobbler "Spacer" with adhesive, ideal for separating the posters with a space.
-  Wobbler "Entretoise" avec adhésif, idéal pour séparer des affiches avec un espace.
-  Wobbler "Spacer" com adesivo ideal para cartazes com um espaço.
-  Wobbler "Spacer" con adhesivo, ideal para separar la cartelera con un espacio.



12.207 13x26x17mm x100 

Ticket Holder

Pin ticket



Schildhalter für Schilder bis zu 1 mm Dicke. Breite: 38mm.

Price holders nailed or inserted into the product.

Porte étiquettes en plastique à utiliser avec matériel jusqu'à 1mm d'épaisseur.

Espeto de plástico que suporta até 1 mm de espessura.

Pin ticket. Soporta material de hasta 1mm de grosor.

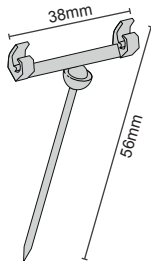
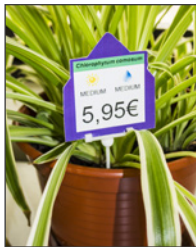

12.462 38x56mm x100

Pin Ticket

Schildhalter wird direkt ins Produkt gesteckt.

Ticket holder pin 60/80mm.

Porte étiquette pour clouer ou insérer dans un produit.

Portapreços para cravar ou inserir num produto.

Portaprecios para clavar o insertar en el producto.

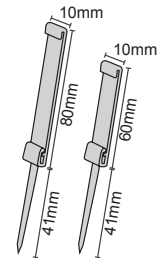

12.209 60mm x100

12.210 80mm x100

Label Holder



Etikettenhalter, Gesamthöhe: 175 mm.

Label holder, total height:175mm.

Porte étiquette. Hauteur maximale: 175mm.

Porta etiquetas. Altura máxima: 175mm.

Porta etiquetas, altura máxima: 175mm.

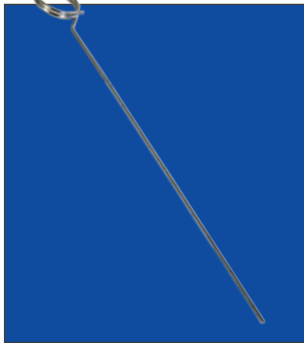
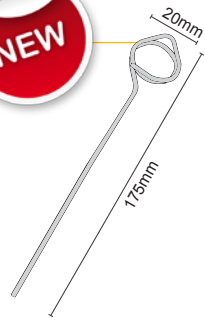

12.461 175mm x100

Hanging Price Holder

Schildhalter aus Kunststoff zur Befestigung an Metallstangen und Körbe.

Price holders made of plastic that allows be placed on brackets with metal rods, such as baskets, trolleys, etc.

Porte étiquette fabriquée en plastique que l'on insère dans les supports avec des tiges métalliques, que l'on attache aux paniers ou dans les self-service, etc.

Portapreços fabricado em plástico que se podem colocar em suportes com varetas metálicas, como cestas, carros de auto-serviço, etc.

Portaprecios realizado en plástico que permite colocarse en soportes con varillas metálicas, como cestas, carros autoservicio, etc.

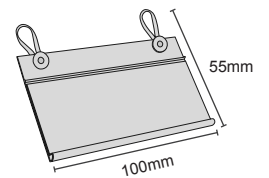

12.295 Graphic 100x40mm x50

Arrow Hole

Preishalter für Flaschen. Geeignet zur Befestigung von verschiedenen Kartonarten.

Price holders for bottles. Its arrow shape allows nailing different types of cardboard.

Porte étiquette pour bouteille. Sa forme de flèche permet la fixation de différent type de cartons.

Porta-preços para garrafas. A sua forma com seta permite fixar diversos tipos de cartão.

Portaprecios para botellas. Su forma de flecha permite clavar distintos tipos de cartón.

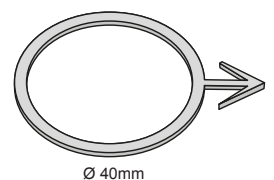
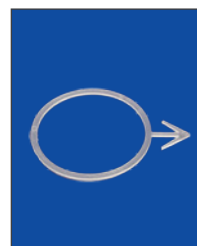

12.296 Ø 40mm x50

Wire Hook Sign Holder



- Schildhalter für Haken. Material Plastik.
- Frontal Gripper for Hook. Plastic.
- Gripper en plastique pour broche.
- Gripper para gancho.
- Gripper para frontal de gancho.

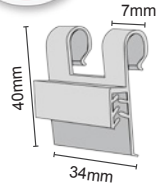

12.230 34x40mm x50

Gripper for Wire Hook



- Schildhalter seitlichen Haken. Länge: 32 mm.
- Gripper lateral hook.
- Gripper pour broche.
- Gripper para gancho.
- Gripper para lateral de gancho.

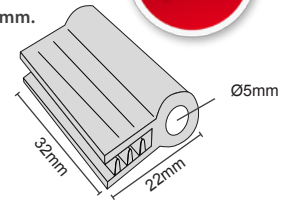

12.450 32mm x100

Hook Label Display

- Einzelhaken. Material: Kunststoff.
- Single hook label holder.
- Etiquette en plastique.
- Gancho de plástico para colocar precios.
- Gancho simple portaprecios.

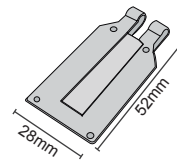
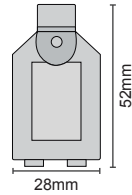

50.123 27x31mm x100

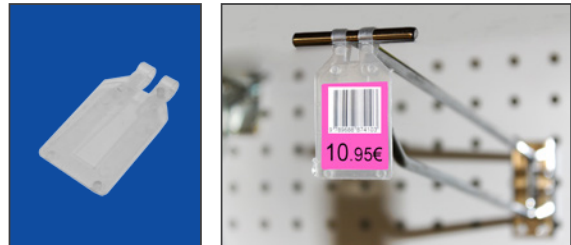

50.119 27x31mm x100

Label Holder

- Kunststoff-Etikettenhalter.
- Label Holder. Material: Plastic.
- Porte étiquettes en plastique.
- Porta etiquetas de plástico.
- Portaetiquetas. Plástico.

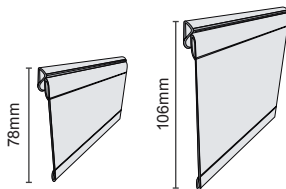
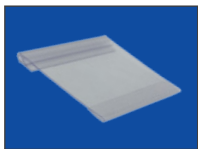

12.414 78x152mm x50

12.417 78x203mm x50

12.419 106x152mm x50

12.421 106x203mm x50



Pin Ticket





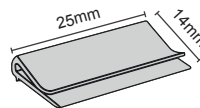

- Transparenter Etikettenhalter. Unterstützt eine maximale Dicke von 1 mm.
- Transparent polystyrene. Supports a maximum thickness of 1mm.
- Support transparent pour étiquette d'une épaisseur maximale de 1mm.
- De poliestireno transparente. Espesura maxima 1mm.
- Poliestireno transparente. Soporta un grosor máximo de 1mm.



12.458 25mm x100

Menu Holder

-  Schildhalter mit Fuß. Ideal für Preisauszeichnungen in Schaufenstern.
-  Price holders with base. Ideal for windows, shelves, etc.
-  Porte étiquette avec socle. Idéal pour vitrines, étagères, etc.
-  Portapreços com base para montras, estantes, etc.
-  Portaprecios con peana. Ideal para escaparates, estanterías, etc.

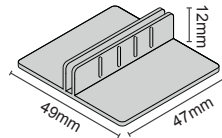
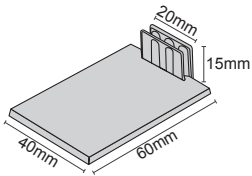

12.460 49x47mm x50 

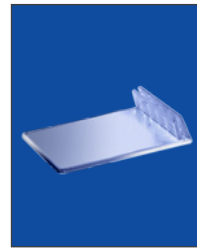
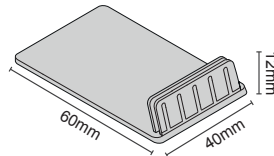
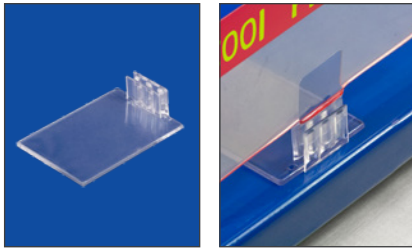





12.208 40x60mm x100 

12.459 40x60mm x50 



Ticket Holder

-  Tickethalter aus Edelstahl mit verstellbarem Winkel.
-  Cabinet ticket holder made of stainless steel. Adjustable angle.
-  Support en acier inoxydable avec ajustable.
-  Suporte em aço inoxidável. Angulo ajustável.
-  Portaticket en acero inoxidable. Inclinable.

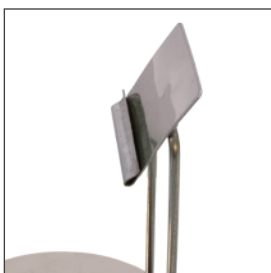
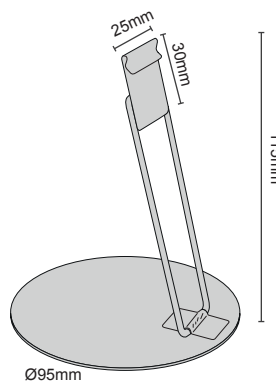

12.519 x100 

Sign Supports and Flags

Präsentationssysteme zur Gestaltung von Regalen.

Sistema de exibição para pontos de venda.

This simple system is suitable for exhibition and points of sale.

Sistemas para ambientar y animar los lineales y estanterías.

Système pour acclimater et animer les bords des étagères.

Magnet Flag Holder

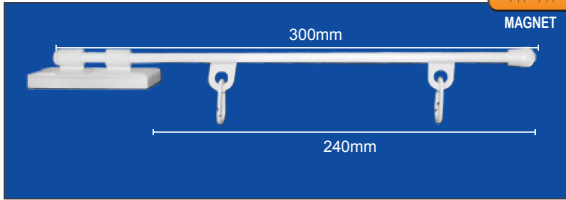

12.173 300mm x10

Banner Holder with Two Adhesive

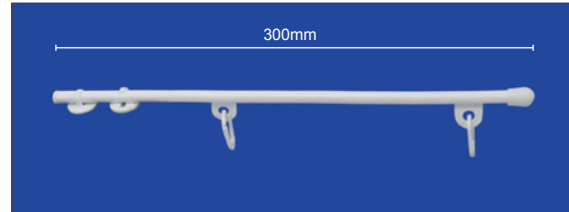

12.180 300mm x20

Adhesive Flag Holder

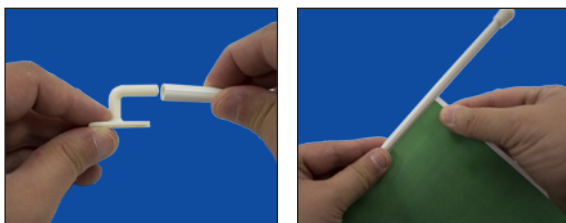
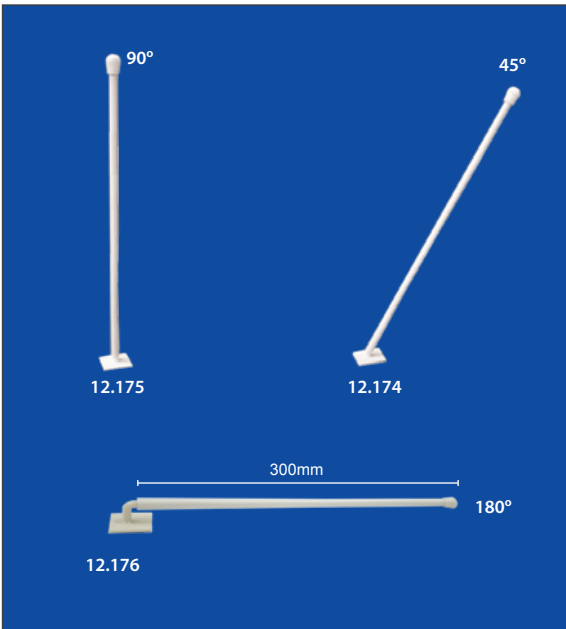

12.174 45° x50

12.175 90° x50

12.176 180° x50

Flag Holder with Adhesive and Ring

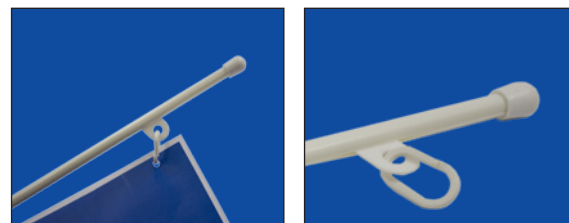
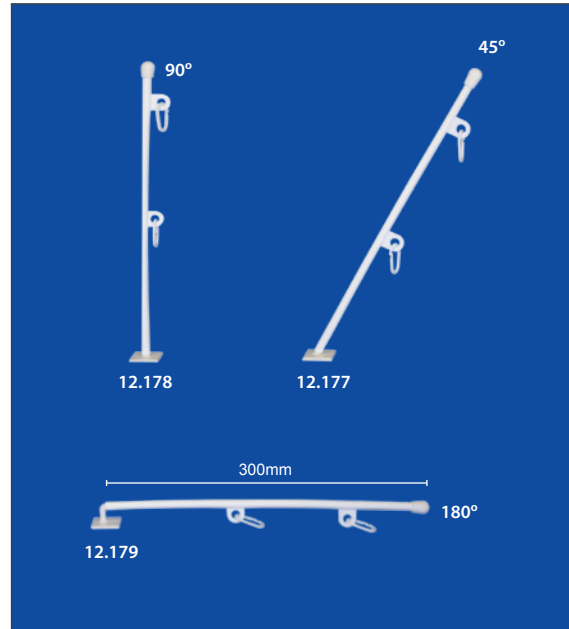

12.177 45° x50

12.178 90° x50

12.179 180° x50

Sign Clip "L" Magnetic

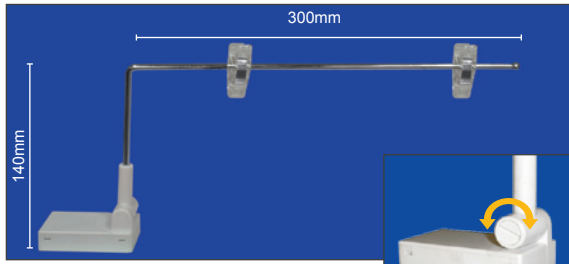

12.302

x10

Sign Clip "L" Magnetic

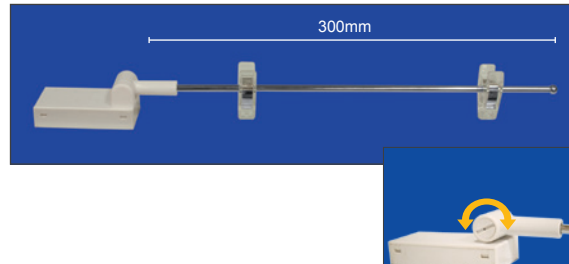

12.303

x10

Sign Clip "L" Magnetic

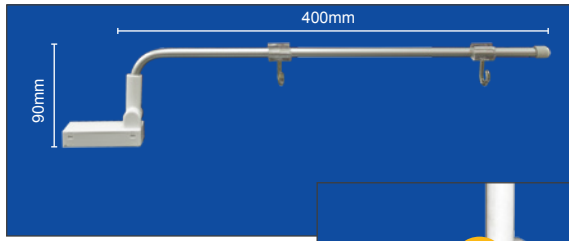

12.381

x10

Sign Gripper "U" Magnetic

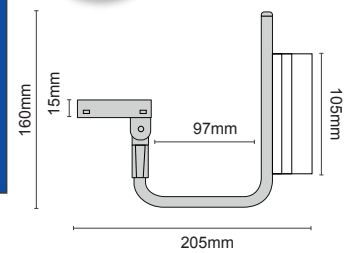

12.511

x2

Adhesive Flag Support

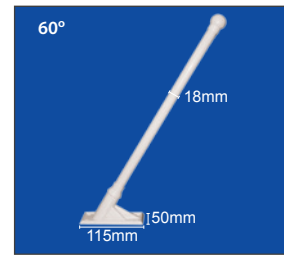
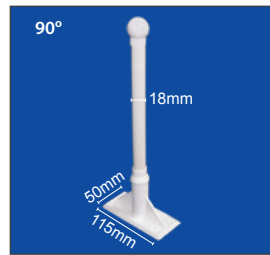
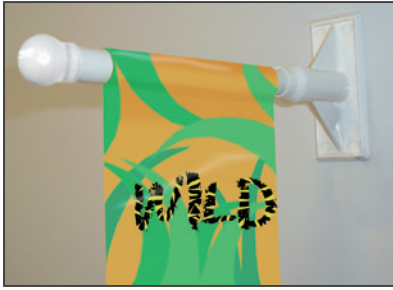

12.297	60°	280mm	x20		
12.299	60°	400mm	x20		
12.289	60°	600mm	x20		
12.298	90°	280mm	x20		
12.288	90°	400mm	x20		
12.290	90°	600mm	x20		

Razz Thin Poster Channel

- Kunststoff-Klemmschiene 300 oder 460mm, zur Befestigung von Schildern mittels L-Magnetfuß (Ref.Nr.: 12.220, 12.221).
- Plastic poster holders measuring 300 or 460mm, ideal for the presentation of posters. Magnet engages in "L" (Reference 12.220, 12.221).
- Porte-affiche de plastique de 300 ou 460mm de longueur, idéal pour la présentation d'affiches. On le place dans un aimant en forme de "L" (Référence 12.220, 12.221).
- Porta-cartaz de plástico em medida de 300 ou 460mm, ideal para a apresentação de cartazes. Coloca-se num íman em "L" (Referência 12.220, 12.221).
- Portacartel de plástico en medida de 300 ó 460mm, ideal para la presentación de cartelería. Se acopla en el imán en "L" (Referencias 12.220, 12.221).

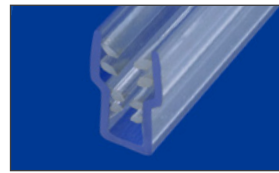
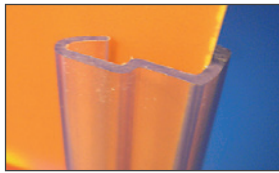
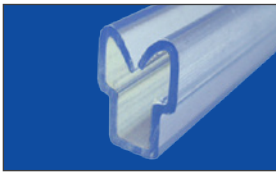

12.218	300mm	x20		
12.219	460mm	x20		

12.216	300mm	x20		
12.217	460mm	x20		

L-Base Magnetic

- Magnetfuß zur Befestigung von Schildern mit Klemmschiene auf Metall-Oberflächen.
- Magnet with "L" disposition for introducing sign holders (gripper or guide) and place on metal surfaces.
- Aimants avec disposition en "L" pour introduire porte affiches (gripper ou guide) et placer sur surfaces métalliques.
- Imanes com disposição em "L" para introduzir porta-cartazes (gripper ou guia) e colocar sobre superfícies metálicas.
- Imanes con disposición en "L" para introducir portacarteles (gripper o guía) y colocar sobre superficies metálicas.

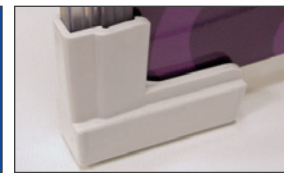
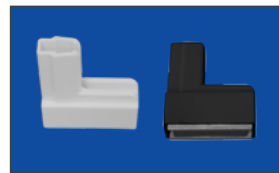
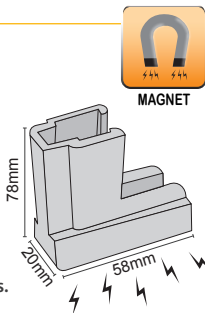

12.220		x20		
12.221		x20		

Magnetic Clip

- Schilderhalter magnetisch, zur Befestigung von Werbeträgern.
- Magnetic clip for sign support. Material: Plastic.
- Clip avec base magnétique pour placer un panneau d'affichage.
- Clip magnético para colocar impressões.
- Clip magnético para colocación de cartelería.

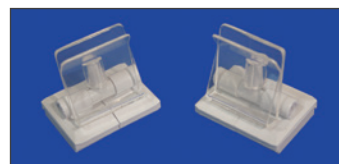

12.078	x50		
--------	-----	--	--

Coupon Holder

Coupon-Heft Halter mit großem Fassungsvermögen, Breite 75mm. Schnelle und einfache Befestigung mittels Klebestreifen oder Klemmschiene an Regalsystemen. 8mm Kapazität für ca. 75 Coupons oder 18mm Kapazität für ca. 125 Coupons (Papierstärke von 115g).

Coupon holders of large capacity. Easy mounting with adhesive or supergrip 75mm wide, ideal for shelving, shelves, etc. 8mm capacity: approx 75 coupons. (paper of 115g). 18mm capacity: approx 125 coupons. (paper of 115g).

Porte coupons de grande capacité. Fixation facile par adhésif ou super grip de 75mm de largeur. Idéal pour des rayons, étagères, etc. Capacité 8mm: 75 coupons approximativement (en papier 115g). Capacité 18mm: 125 coupons approximativement (en papier 115g).

Porta-cupões de grande capacidade. De fácil fixação mediante adesivo ou supergrip de 75mm de largura. Ideal para estantes, prateleiras, etc. Capacida 8mm: 75 cupões aprox. (papel de 115g). Capacidade 18mm: 125 cupões aprox. (papel de 115g).

Portacupones de gran capacidad. De fácil fijación mediante adhesivo o supergrip de 75mm de ancho, ideal para estanterías, baldas, etc. Capacidad 8mm: 75 cupones aprox. (papel de 115g). Capacidad 18mm: 125 cupones aprox. (papel de 115g).

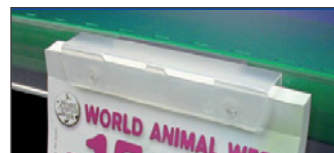

12.212 **8mm** x20

12.214 **18mm** x20

12.213 **8mm** x20

12.215 **18mm** x20

"Spiral"

Schilderhalter für Regalsysteme. Befestigung der Grafik mittels Klebepad mit hoher Haftbarkeit.

Portastopper for front rack, the signage is supported by adhesive.

Stop Rayon à placer à l'avant de l'étagère. L'affiche est fixée par un adhésif.

Portastopper para frontal de estante. O cartaz é fixado através de um adesivo grande.

Portastopper para frontal de estante, la cartelera se sustenta mediante adhesivo.



12.232 **30x70mm** x20

Datastrip Stopper

Stopper für Leisten in 90°. Durchsichtiger Kunststoff.

Stopper for Datastrip can be placed in 90°. Clear plastic.

Stop Rayon en plastique transparent.

Stopper para Datastrip para colocar em 90°.

Stopper para Datastrip se puede colocar en 90°. Plástico transparente.

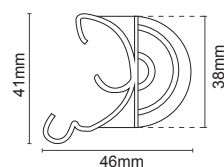

12.474 x100

Shelf Edge Poster Brackets

Fahnenhalter mit einer Höhe von 85mm für perforierte Regalsysteme mit 54mm Lochabstand. Inklusive Metallstift zur Befestigung.

Portastopper 85mm high. Fits perforated shelves to 54mm spaced holes. Includes metal clip for portastopper; shelves this subject.

Stop rayon de 85mm de hauteur. Adaptable aux étagères perforées avec 54mm d'espacement entre les trous. Un clip métallique pour stop rayon est inclus. Il se fixe aux étagères perforées.

Portastopper de 85mm de altura. Adapta-se às prateleiras perfuradas com 54mm de espaçamento entre os furos. Inclui clip metálico para portastopper; Fixa-se às prateleiras perfuradas.

Portastopper de 85mm de altura. Se adapta a baldas perforadas, para taladros espaciados 54mm. Incluye clip metálico para portastopper; éste sujeta las baldas.



12.222 **85mm** x50

Shelf Edge Poster Brackets 3 Positions

Fahnenhalter für perforierte Regalsysteme mit 54mm Lochabstand. Winkel-Einstellungen: 45°, 90° oder 180°. Inklusive Metallstift zur Befestigung.

Portastopper with 3 positions can be placed in 90°, 45° and fully horizontal. Fits perforated shelves to 54mm spaced holes. Includes metal clip for portastopper.

Stop Rayon avec 3 positions que l'on peut placer dans un angle de 90° ou de 45° degrés ou à l'horizontal. Adaptable aux étagères perforées avec 54mm d'espacement entre les trous. Un clip métallique pour stop rayon est inclus. Il se fixe aux étagères perforées.

Portastopper com 3 posições que se pode colocar a um ângulo de 90° ou 45° graus ou na horizontal. Adapta-se às prateleiras perfuradas com 54mm de espaçamento entre os furos. Inclui clip metálico para portastopper; Fixa-se às prateleiras perfuradas.

Portastopper con 3 posiciones, se puede colocar en 90°, 45° y totalmente horizontal. Se adapta a las baldas perforadas, para taladros espaciados 54mm. Incluye clip metálico para portastopper; éste sujeta las baldas.



12.223 **145mm** x50

NAME BADGES

9

Name Badges

🇩🇪 Verschiedene Halterungen, Clips für z.B. Namensschilder, Ausweise, mit verschiedenen Befestigungssystemen (unter Verwendung von Klebeband, Magneten, Klammern ...) verschiedenen Farben und Materialien erhältlich.

🇬🇧 Different formats for card holders and nameplates (using adhesives, magnetic, safety pins...) Available in various colors and materials.

🇫🇷 Support pour badges ou cartes d'identification (fixés par adhésifs, magnétiques, épingles etc). Disponibles en différents colories et matériaux.

🇵🇹 Suportes para crachás com diferentes sistemas (magnéticos, pinça ou alfinete). Disponíveis em diferentes materiais e cores.

🇪🇸 Diferentes soportes para portatarjetas y chapas de identificación (mediante adhesivos, magnéticos, imperdibles...) varios colores y materiales disponibles.



12.439 40x12mm x50

12.440 40x7mm x50

12.441 52x20mm x50



12.100 32x12mm x50



12.101 40x10mm x50



12.102 19x19mm x50

Hung Clamp

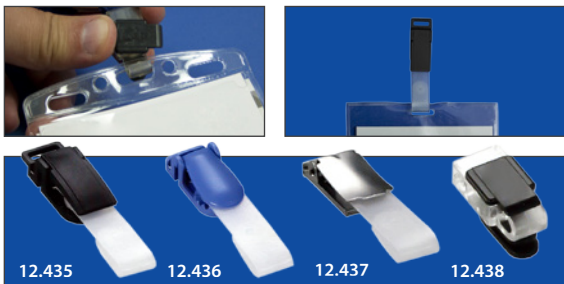

12.435 x50

12.436 x50

12.437 x50

12.438 x50

Metal Clamp



12.442 24x12mm x50

12.443 25x15mm x50

12.164 10x27mm x100

Hanger Magnetic - Pin Clamp



12.433 x50

NAME BADGES

Badge Pin

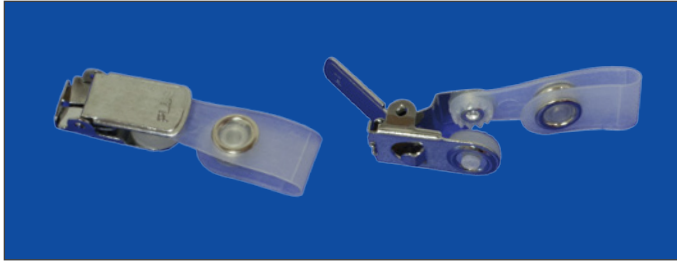

12.110 x50

Name Badge

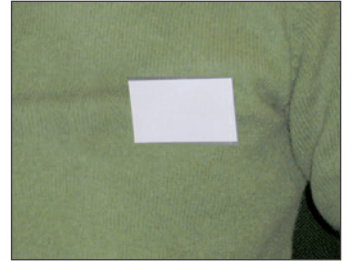
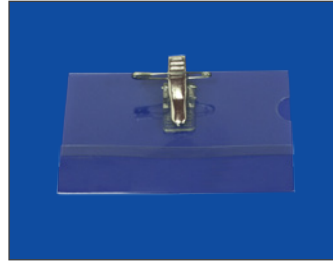

12.105 90x55mm x50

Acrylic Pin Name Badges

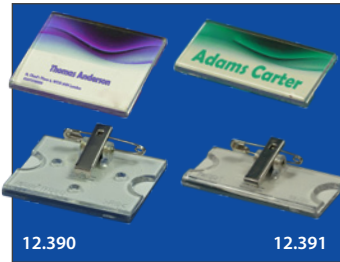

12.390 12.391

12.390 50x40mm x10

12.391 60x25mm x10

Pin Name Badges

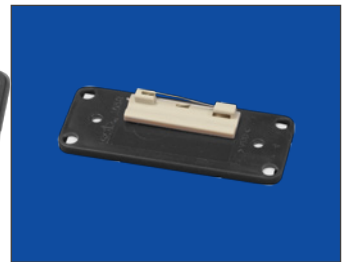
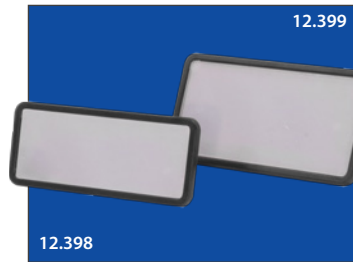

12.398 12.399

12.398 75x25mm x10

12.399 75x35mm x10

Magnet Name Badges

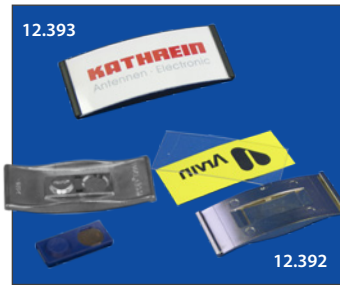

12.392 12.393

12.392 75x32mm x10

12.393 75x32mm x10

Pin Name Badges



12.394 12.395

12.394 75x32mm x10

12.395 75x32mm x10

Magnet Name Badges

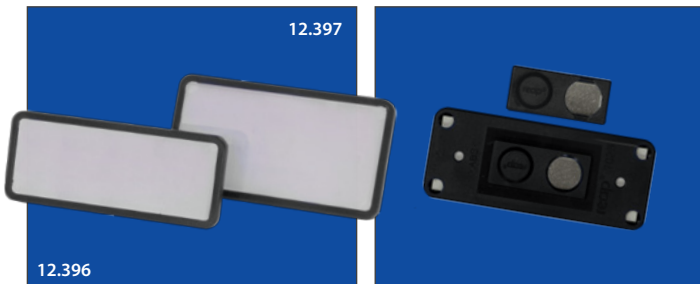

12.396 12.397

12.396 75x25mm x10

12.397 75x35mm x10



NAME BADGES

9

Soft PVC Card Holders



12.107		95x55mm	x50		
12.108		80x105mm	x50		
12.109		105x150mm	x50		

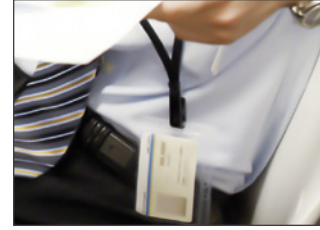

*Band ist nicht enthalten / Rope is not included / Cordon non inclus / Cordão não incluído / Cordon no incluido.

Card Holder



12.106	86x54mm	x10		
--------	---------	-----	--	--

Acrylic ID/IC Card Case



12.413	54x86mm	x10		
--------	---------	-----	--	--



Acrylic ID/IC Card Case



12.411		54x86mm	x10		
12.412		86x54mm	x10		

Vertical/Horizontal ABS Card Holder



12.422	89x49mm	x10		
--------	---------	-----	--	--

SUSPENSION ROPE

"Yo Yo" for Badges



12.103

12.104

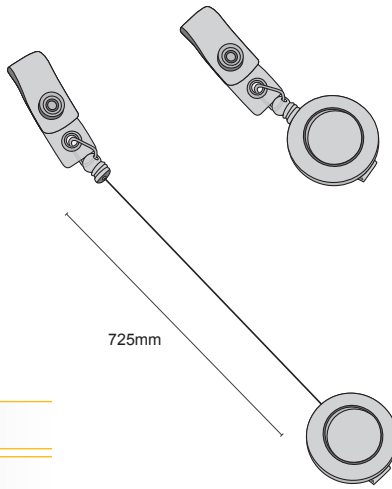

725mm



12.103		x50		
12.104		x50		

Multifuncional Dual Colour Suspension Rope



12.431 450x11mm x50

Plastic Button Dual Colour Suspension Rope



12.432 450x11mm x50

Metal Clip Suspension Rope



12.429 450x11mm x50



Mobile Kits

Die Triaramas bestehen aus 2 Kunststoff-Aufhängern mit 3 oder 4 Seiten zur Befestigung von Werbeträgern.

The triaramas consist of two pieces of plastic available in 3 or 4 sides for display advertising. Ideal for indoor use.

Les prismes sont formés par deux pièces de plastique, pour disposer 3 ou 4 visuels de publicité sur les côtés. Idéal pour une utilisation intérieure.

Os triaramas estão formados por duas peças de plástico com disposição em 3 ou 4 lados para a visualização da publicidade. Ideal para uso em interiores.

Los triaramas están formados por dos piezas de plástico con disposición en 3 ó 4 lados para la visualización de la publicidad. Ideal para su uso en interiores.

Mobile Kit - Trimaxi

Lochabstand: 317mm. Loch-Durchmesser: 5mm. Grafikgröße: von 400mm bis 750mm (mind. 330mm).

Distance between holes: 317mm. Holes Ø 5mm. Graphic size: 400mm to 750mm (minimum 330mm). Material: Plastic.

Distance entre les trous: 317mm. Trous: 5mm. Dimension de l'impression: à partir de 400mm jusqu'à 750mm (minimum 330mm).

Distância entre buracos: 317mm. Buracos: 5mm. Tamanho da Impressão: desde 400mm até 750mm (mínimo 330mm).

Distancia entre agujeros: 317mm. Agujeros: 5mm. Tamaño gráfica: desde 400mm a 750mm (mínimo 330mm).

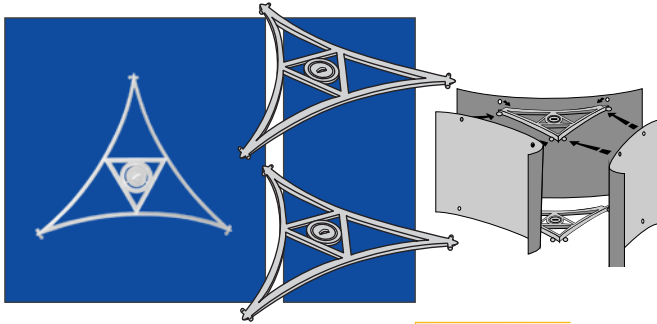

12.234

x2

Mobile Kit - Trimedium

Lochabstand: 160mm. Loch-Durchmesser: 5mm. Grafikgröße: von DIN A4 bis 400mm (mind. 200mm).

Distance between holes: 160mm. Holes Ø 5mm. Graphic size: A4 to 400mm (minimum 200mm). Material: Plastic.

Distance entre les trous: 160mm. Trous: 5mm. Dimension de l'impression: à partir d'un A4 jusqu'à 400mm (minimum 200mm).

Distância entre buracos: 160mm. Buracos: 5mm. Tamanho da Impressão: desde um A4 até 400mm (mínimo 200mm).

Distancia entre agujeros: 160mm. Agujeros: 5mm. Tamaño gráfica: desde un A4 hasta 400mm (mínimo 200mm).

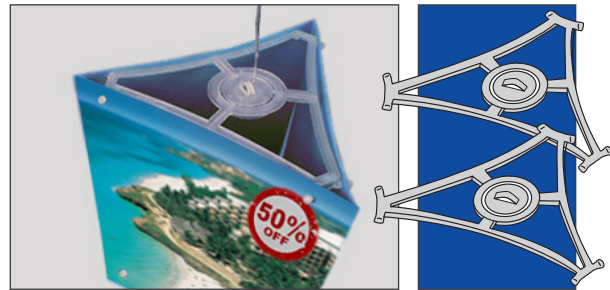

12.235

x2

Mobile Kit - Quadrama

Lochabstand: 160mm. Loch-Durchmesser: 5mm. Grafikgröße: von DIN A4 bis 400mm (mind. 200mm).

Distance between holes: 160mm. Holes Ø 5mm. Graphic size: A4 to 400mm (minimum 200mm). Material: Plastic.

Distance entre les trous: 160mm. Trous: 5mm. Dimension de l'impression: à partir d'un A4 jusqu'à 400mm (minimum 200mm).

Distância entre buracos: 160mm. Buracos: 5mm. Tamanho da Impressão: desde um A4 até 400mm (mínimo 200mm).

Distancia entre agujeros: 160mm. Agujeros: 5mm. Tamaño gráfica: desde A4 a 400mm (mínimo 200mm).

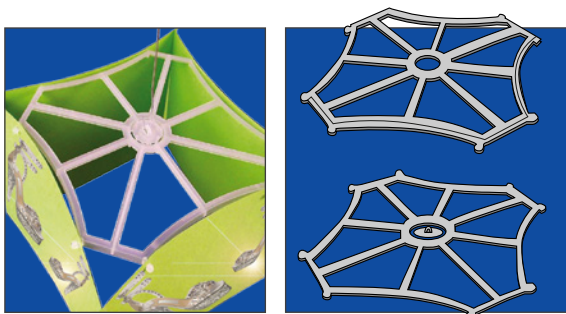

12.236

x2

Mobile Kit - Minirama

Lochabstand: 105mm. Loch-Durchmesser: 5mm. Grafikgröße: von DIN A4 bis 400mm (mind. 200mm).

Distance between holes: 105mm. Holes Ø 5mm. Graphic size: A4 to 400mm (minimum 200mm). Material: Plastic.

Distance entre les trous: 105mm. Trous: 5mm. Dimension de l'impression: à partir d'un A4 jusqu'à 400mm (minimum 200mm).

Distância entre buracos: 105mm. Buracos: 5mm. Tamanho da Impressão: desde um A4 até 400mm (mínimo 200mm).

Distancia entre agujeros: 105mm. Agujeros: 5mm. Tamaño gráfica: desde un A4 hasta 400mm (mínimo 200mm).



12.067

x2





SIGNS

Sign System	322
Wall Flag Signs	329
Desk Signs	332
Wall Mounting Panel Supports	334
LED Sign System	336
Cube System	337
Panel Support	338
Outdoor Sign	340

Sign System "Louvre"

Infotafel als Glas-Sandwich-Rahmen mit Halterung, Glasscheibe 3mm, für Innenräume. Lieferung als komplettes Set. Set enthält:

- Halter (1 oder 2), Aluminiumprofil. *Anwendung: Versammlungsräume, Büros, Eingänge, etc.
- 2 Glasscheiben, Stärke 3mm. *Materialempfehlung: Fotopapier, Vinyl-Display, etc. Schnelle und einfache Montage. Befestigungsschrauben nicht enthalten.
- Kunststoff-Abdeckkappen.
- Montageschlüssel.

Interior signage system consists of a "sandwich" of glass 3mm thickness each. Supplied in complete kits. Content:

- Aluminium profile (1 or 2). * Indoor usage: Meeting rooms, offices, portals, etc...
- Two 3mm thickness glasses. * Recommended Materials: Paper photographic, vinyl cutting, etc.. And fast assembly. Fixing screws not included.
- Plastic endcaps.
- Screw key.

Système de signalisation intérieur composé d'un "sandwich" en verre de 2 faces de 3mm d'épaisseur chacune. Vendus en jeux complets. Contenu:

- Profil d'aluminium (1 ou 2). *Utilisation: intérieur, salles de réunion, bureaux, façades, etc.
- Deux vitres de 3mm d'épaisseur. *Matières recommandées: papier photographique, vinyle de coupe, etc. Montage rapide et facile. Vis non incluses.
- Bouchons latéraux.
- Outil pour le montage.

Sistema de sinalização interior composto por uma "sandwich" de vidro de 3mm de espessura cada uma. Fornece-se em kits completos. Conteúdo:

- Perfil de alumínio (1 ou 2). *Uso: Interiores, salas de reuniões, escritórios, fachadas, etc.
- Dois vidros de 3mm de espessura. *Materiais recomendados: Papel fotográfico, vinil de corte, etc. Montagem rápida e fácil. Parafusos não incluídos.
- Tampas laterais de plástico.
- Ferramenta para a montagem.

Sistema de señalización interior compuesto por un "sandwich" de cristal de 3mm de espesor cada uno. Se suministra en kits completos. Contenido:

- Perfil de aluminio (1 ó 2). *Uso: Interior. Salas de juntas, oficinas, portales, etc.
- Dos cristales de 3mm de espesor. *Materiales recomendados: Papel fotográfico, vinilo de fijación, etc. Fácil y rápido montaje. Tornillería de fijación no incluidos.
- Tapas laterales de plástico.
- Llave para el montaje.

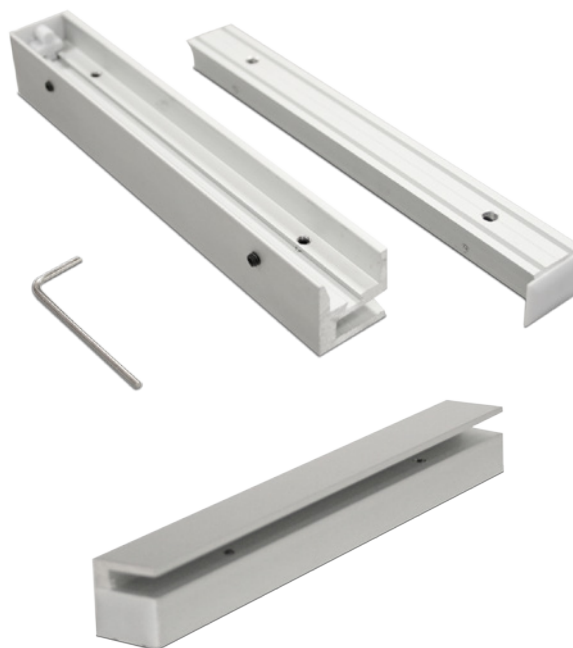

Simple Profile

15.571		105x105mm	
15.572		105x149mm	
15.573		149x105mm	
15.574		149x149mm	
15.575		149x210mm	
15.576		210x149mm	
15.577		297x105mm	
15.578		297x149mm	
15.579		297x210mm	
15.580		420x149mm	
15.581		594x149mm	
15.582		840x149mm	
15.583		840x210mm	

 **Installationsanleitung:**

1. Befestigen der Aluminiumschiene in gewünschter Position an der Wand.
2. Einsetzen der Glasscheiben in das Aluminiumabdeckung und verschrauben.
3. Aluminiumabdeckung auf Schiene setzen und verschrauben.
4. Anbringen der Kunststoff-Abdeckkappen an den Profilenenden.

 **Install explanation:**

1. Attach/Fasten the aluminum surface with screws in the place where you want.
2. Insert the glass into the aluminium surface. Secure with screw.
3. Attach the two surfaces together with the bottom screw.
4. Attach the plastic caps on the ends of the aluminum surface.

 **Installation:**

1. Fixer le profil en aluminium avec les vis.
2. Introduire les plaques en verre dans la rainure de la 2ème pièce en aluminium.
3. Fixer les deux pièces ensemble avec les vis.
4. Placer les bouchons en plastique aux extrémités.

 **Instalação:**

1. Fixe a superfície de alumínio com os parafusos onde pretender.
2. Introduzir o vidro na superfície de alumínio. Fixar o parafuso.
3. Fixe as duas superfícies juntas com o parafuso inferior.
4. Coloque as tampas de plástico nos extremos da superfície de alumínio.

 **Instalación:**

1. Sujete la superficie de aluminio con tornillos en el lugar donde usted quiera.
2. Introducir el cristal en la superficie de aluminio. Fijar con tornillo.
3. Fije las dos superficies juntas con el tornillo inferior.
4. Coloque las tapas de plástico en los extremos de la superficie de aluminio.



Install explanation

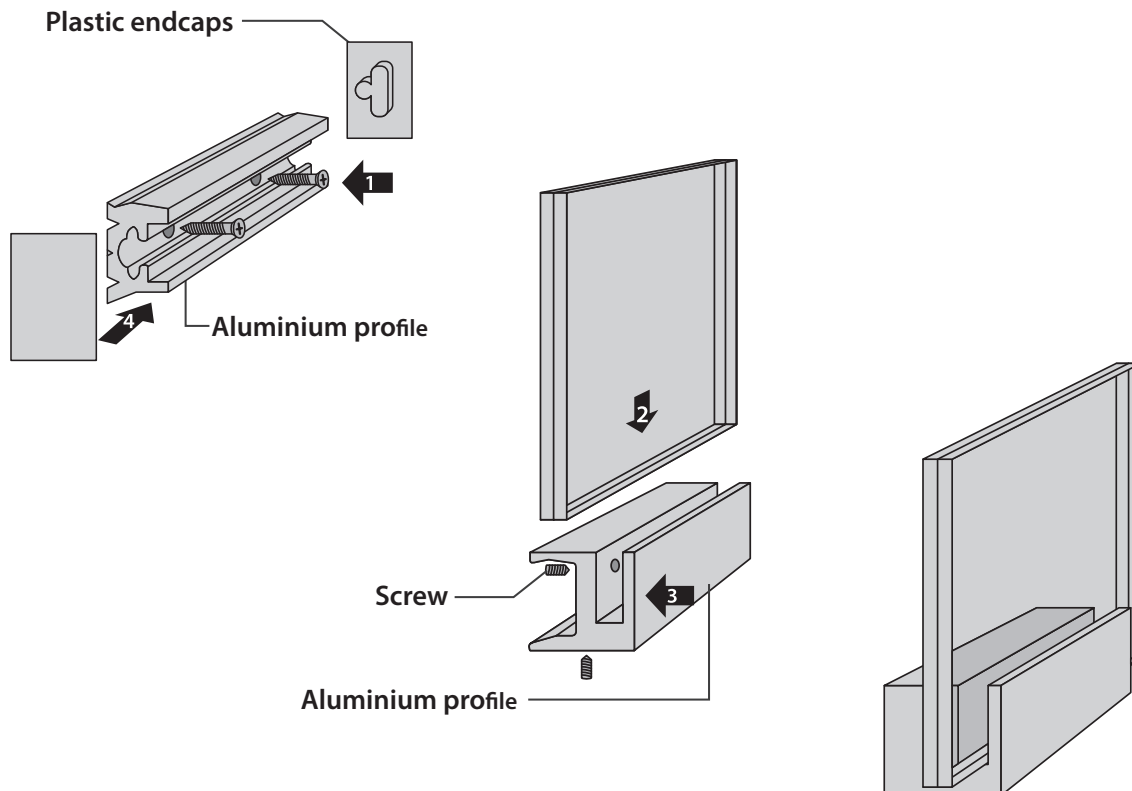

Sing System Straight-Curve

 Informationssystem Standard mit eckigen (BARGELLO) oder abgerundeten (ORSAY) Aluminiumprofilen. In verschiedenen Standardformaten verfügbar. Lieferung als komplettes Set. Set enthält:

- Seitlich gerade oder gebogene Aluminiumprofile.
- Kunststofffixierer.
- Gerade Aluminiumprofile.
- Kunststoffendkappen.
- * Innenbereich: Büro, Badezimmer, Gebäude usw.
- * Einfach und schnell zu montieren.

 Standard Information System, consisting of aluminum profiles STRAIGHT (BARGELLO) or CURVED (ORSAY) and aluminum plates. Available in standard formats of various sizes. Supplied in complete kits. Content:

- Profile of aluminum STRAIGHT or CURVED.
- Plastic pieces for fixing.
- Aluminium straight sign profile.
- Plastic endcaps.
- * Indoor use: office, Signage office, hall, door, meeting rooms, etc...
- * Recommended materials: vinyl cutting and digital printing.
- * Application: with screws or double-sided adhesive. Quick and easy assembly. Graphic and screws not included.

 Système d'information Standard composé d'un profil en aluminium DROIT (BARGELLO) ou COURBÉ (ORSAY) et d'une plaque en aluminium. Plusieurs dimensions disponibles.

- Profil en aluminium droit ou courbé.
- Plastique de fixation.
- Plaque en aluminium.
- Bouchons latéraux.
- * Utilisation: à l'intérieur, signalisation de bureaux, hall d'entrée, porte d'accès, salles de réunion, etc.
- * Matières recommandées: vinyle de coupe et impression digitale.
- * Application: au moyen de vis ou adhésif double face. Montage facile et rapide. Vis non incluses.

 Sistema de sinalização em alumínio. Perfil lateral RECTO (BARGELLO) ou CURVO (ORSAY). Kits completos que incluem:

- Perfil de alumínio lateral reto ou curvo.
- Plásticos de fixação.
- Placa de alumínio.
- Tampas laterais.
- *Uso: Interiores, sinalização de escritórios, hall, porta de acesso, salas de reuniões, etc.
- *Materiais recomendados: vinil de corte e impressão digital.
- *Aplicação: mediante parafusos ou adesivo duplo. Montagem fácil e rápida. Impressão e parafusos não incluídos.

 Sistema informativo estandar, compuesto de perfilera de aluminio RECTA (BARGELLO) o CURVA (ORSAY) y placas de aluminio. Disponible en formatos estandar de varios tamaños. Se suministra en kits completos. Contenido:

- Perfil de aluminio RECTO o CURVO.
- Plásticos de fijación.
- Placa de aluminio.
- Tapas laterales.
- *Uso: interior. Señalización de oficinas, hall, puertas de acceso, salas de juntas, etc.
- *Materiales recomendados: vinilo de corte e impresión digital.
- *Aplicación: mediante tornillos o adhesivo doble cara. Fácil y rápido montaje. Gráfica y tornillería no incluidos.



Bargello

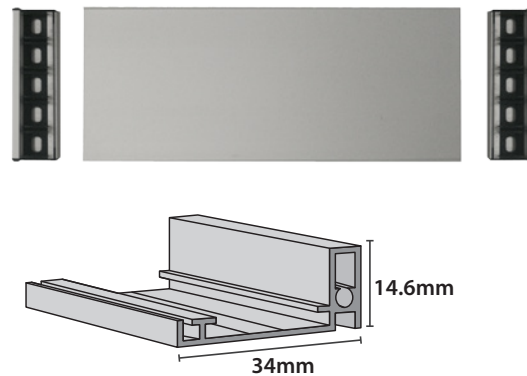

15.634	120x60mm	
15.635	220x60mm	
15.636	300x60mm	
15.637	150x90mm	
15.638	220x90mm	
15.639	300x90mm	
15.668	124x120mm	
15.640	150x124mm	
15.641	220x124mm	
15.642	300x124mm	

15.670	150x150mm	
15.643	220x150mm	
15.644	300x150mm	
15.645	400x150mm	
15.672	180x180mm	
15.646	500x60mm	
15.647	500x90mm	
15.648	500x124mm	
15.649	500x150mm	
15.650	500x180mm	

Orsay

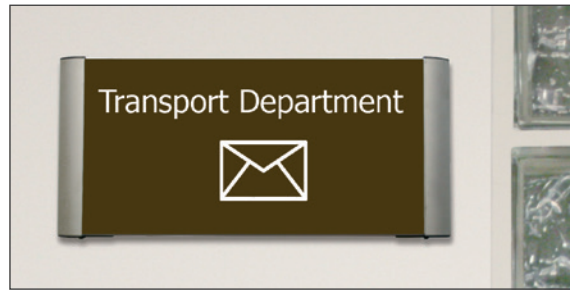
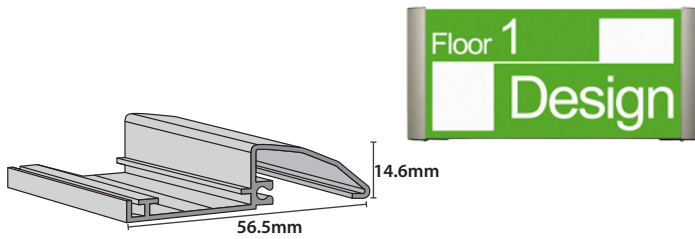

15.651	120x60mm	
15.652	220x60mm	
15.653	300x60mm	
15.654	150x90mm	
15.655	220x90mm	
15.656	300x90mm	
15.657	150x124mm	
15.658	220x124mm	
15.659	300x124mm	

15.660	220x150mm	
15.661	300x150mm	
15.662	400x150mm	
15.663	500x60mm	
15.664	500x90mm	
15.665	500x124mm	
15.666	500x150mm	
15.667	500x180mm	

Installationsanleitung:

- Bohren der Löcher entsprechend der Breite des Infoschildes, innerhalb der ovalen Löcher in den Seitenteilen. (Für die Befestigung mittels doppelseitigen Klebeband ist dieser Schritt nicht notwendig).
- Befestigungsschienen an die Wand schrauben, Abstand entsprechend des Aluminiumprofils. Befestigung mittels doppelseitigen Klebebands. Band auf Rückseite der beiden Befestigungsschienen kleben. Schienen werden wie zuvor beschrieben mit entsprechendem Abstand an der Wand angebracht.
- Sind die Kunststoffschienen an der Wand befestigt, werden die Aluminiumprofile aufgedrückt.

Install explanation:

- Make holes in the oval gaps that are in the sides covers. (This step is not whether to fix with double-sided tape).
- Screw caps to the wall, adjusting the width of the aluminum profile. In the case of double-sided tape is placed on the back of the caps and placed on the wall as the above.
- Once subjected to the wall, is placed above the aluminum pressing, until it is secured.

Installation:

- Faire quelques perforations dans les cavités ovales des bouchons latéraux. (Cette étape ne se fait pas si l'on choisi une fixation avec de l'adhésif double face).
- Visser au mur les bouchons, en les ajustant à la largeur du profil en aluminium. Si on utilise l'adhésif double face, on le place dans la partie arrière des bouchons et après sur le mur, comme dans la description précédente.
- Une fois les bouchons fixés sur le mur, on le place en haut du profil en aluminium, en faisant pression jusqu'à ce qu'il soit bien maintenu.

Instalação:

- Fazer algumas perfurações nas cavidades ovaladas que estão nas tampas laterais. (Este passo não se segue caso se opte por fazer a fixação com fita adesiva dupla).
- Aparafusar à parede as tampas, ajustando à largura do perfil de alumínio. No caso da fita dupla, coloca-se na parte traseira das tampas e coloca-se na parede, como a descrição anterior.
- Uma vez fixas as tampas na parede, coloca-se em cima o perfil de alumínio, pressionando até que fique seguro.

Instalación:

- Realizar unos agujeros en los huecos ovalados que hay en las tapas laterales. (Este paso no se sigue si se va a fijar con cinta de doble cara).
- Atornillar a la pared las tapas, ajustándose a la anchura del perfil de aluminio. En el caso de la cinta de doble cara se pone en la parte trasera de las tapas y se coloca sobre la pared como lo dicho anteriormente.
- Una vez sujetas las tapas a la pared, se coloca encima el perfil de aluminio presionando, hasta que quede sujeto.

Install explanation

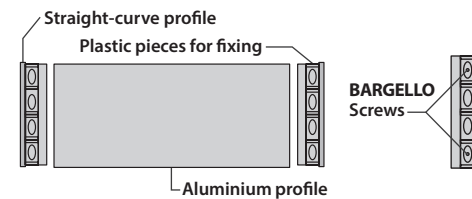
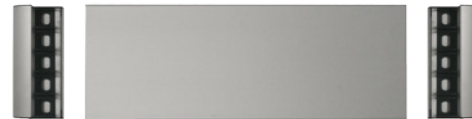

Curved Sign System "Special"

Standard Info-/Leitsystem, aus konvex gewölbten Aluminium Profilen und Aluminium Platten. Das Standard-Modell ist in mehreren Größen verfügbar. Lieferung als komplettes Set. Set enthält:

- Abgerundet Aluminium Profil.
- 2 Abschlusskappen.
- Konvex gewölbte Aluminium Platte.

*Anwendung: Innenraum. Beschilderung für Versammlungsräume, Büros, Ein- und Ausgänge, Hallen etc.

*Materialempfehlung: Digitaldrucke, Vinyl-Display etc.

*Befestigung: mittels Schrauben oder doppelseitigen Klebeband. Schnelle und einfache Montage. Befestigungsschrauben nicht enthalten.

STANDARD CURVED Information System, compound of an curved aluminum profiles and aluminum plates. Available in standard formats of various sizes. Supplied in complete kits. Content:

- Curved aluminium profile.
- Two plastic end caps.
- Curved aluminium plate.

* Indoor use. Office signage, hall, door, meeting rooms, etc..

* Recommended materials: vinyl cutting and digital printing.

* Application: with screws or double-sided adhesive.

Quick and easy assembly. Screws not included.

Système d'information Standard Courbe composé d'un profil en aluminium courbé et des plaques en aluminium. Plusieurs dimensions disponibles. Jeux complet fournit. Contenu:

- Profil en aluminium courbé.
- 2 Bouchons latéraux.
- Plaque d'aluminium courbée.

*Utilisation: à l'intérieure, signalisation de bureaux, hall d'entrée, porte d'accès, salles de réunion, etc.

* Matières recommandées: vinyle de coupe et impression digitale.

*Application: au moyen de vis ou adhésif double face.

Montage facile et rapide. Vis non inclus.

Sistema informativo CURVO STANDAR, composto de perfilaria de alumínio CURVO e placas de alumínio. Disponível em formatos standar e vários tamanhos. Fornece-se em kits completos. Conteúdo:

- Perfil de alumínio CURVO.
- 2 tampas laterais.
- Placa de alumínio CURVA.

*Uso: interiores. Sinalização de escritórios, hall, portas de acesso, salas de reuniões, etc.

*Materiais recomendados: vinil de corte e impressão digital.

*Aplicação: mediante parafusos ou adesivo duplo.

Montagem fácil e rápida. Parafusos não incluídos.

Sistema informativo CURVO ESTÁNDAR, compuesto de perfilaria de aluminio CURVO y placas de aluminio. Disponible en formatos estándar de varios tamaños. Se suministra en kits completos. Contenido:

- Perfil de aluminio CURVO.
- 2 Tapas laterales.
- Placa de aluminio CURVA.

*Uso: interior. Señalización de oficinas, hall, puertas de acceso, salas de juntas, etc.

*Materiales recomendados: vinilo de corte e impresión digital.

*Aplicación: mediante tornillos o adhesivo doble cara.

Fácil y rápido montaje. Tornillería no incluida.

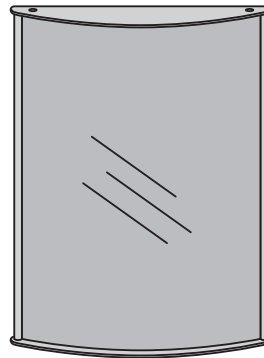

Install explanation

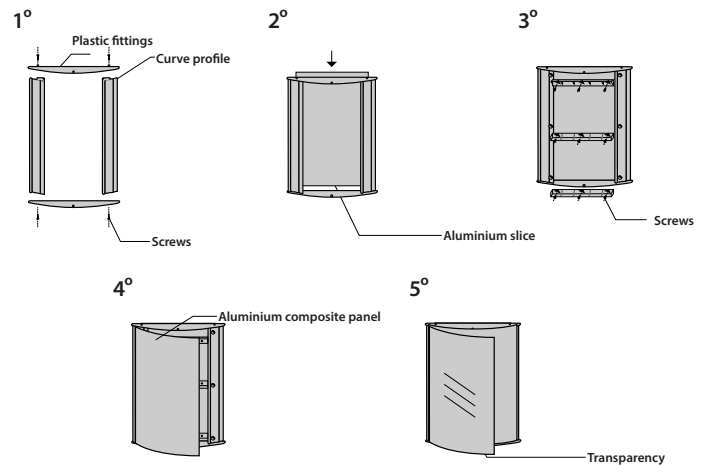

Installationsanleitung:

1. Stecken Sie die Kunststoff - Abschlusskappen auf die Aluminium Profile und verschrauben Sie sie. (s.Abb).
2. Befestigen Sie die Aluminium Platte und schrauben sie das Info-System an der Wand.
3. Drücken Sie zuerst das gewölbte Aluminium- und dann das transparente Panel auf die Wandhalterung.

Install explanation:

1. Join aluminum plate with plastic caps and curved profiles, as in the picture and screw.
2. Place the transparent panel on the stand and tighten to secure.

Installation:

1. Insérer les bouchons en plastique sur les latéraux et les profils courbés comme indiqué sur l'image. Les fixer avec les vis.
2. Placer le panneau transparent sur le support et presser pour le fixer.

Instalação:

1. Una a placa de alumínio com as tampas de plástico e os perfis curvos, como na imagem e una com os parafusos.
2. Coloque o painel transparente sobre o suporte e aperte para fixá-lo.

Instalación:

1. Une la placa de aluminio con las tapas de plástico y los perfiles curvos, como en la imagen y atornillar.
2. Colocar el panel transparente sobre el soporte y apretar para sujetarlo.

15.614	200x200mm	
15.615	200x250mm	
15.616	200x300mm	
15.617	300x400mm	
15.618	500x500mm	

Sign System Data Frame

 Schild mit Kunststoffrahmen. Erhältlich in drei verschiedenen Größen. Einfacher grafischer Informationsaustausch.



 Signaling system with plastic frame. Available in three different sizes. Graphical information exchange easy.

 Système de signalisation avec cadre en plastique. Visuel facile à changer. Trois dimensions disponibles.

 Sistema de sinalização com perfil de plástico. Disponível em três tamanhos. Fácil de mudar a informação, a impressão, etc.

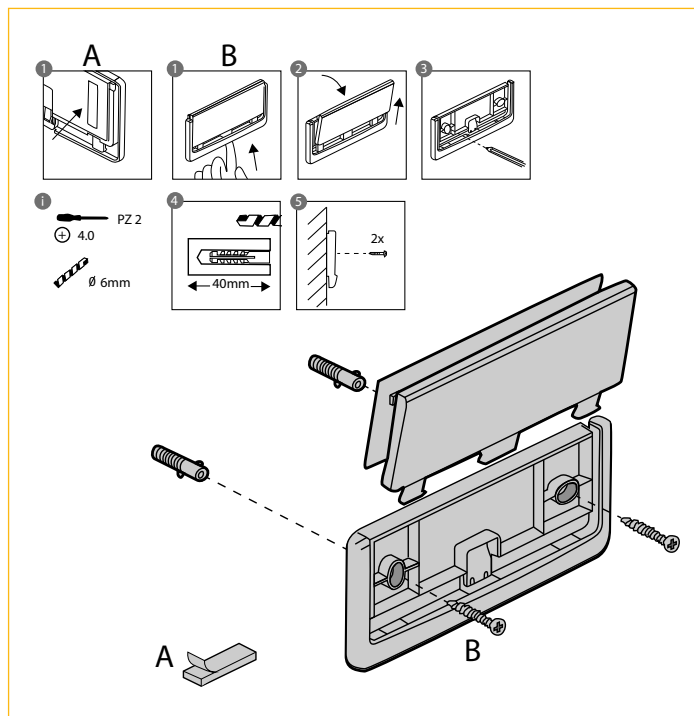
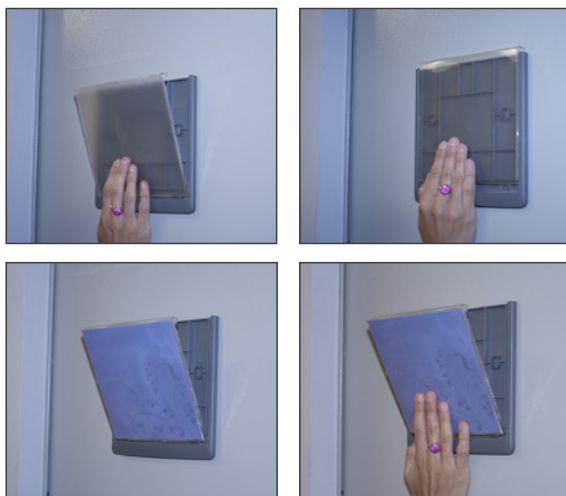
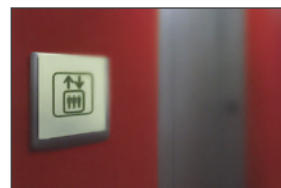
 Sistema de señalización con marco de plástico. Disponible en tres tamaños diferentes. Gráfica informativa fácil de intercambiar.





15.200		149x63mm	
15.201		149x104mm	
15.202		149x145mm	

Curved Sign System "Beyeler"

 Zusammengesetztes Info-/Leitsystem aus Aluminium Profil und seitlichen Abschlusskappen. In 3 verschiedenen Breiten verfügbar. Das Leitsystem kann individuell durch das Hinzufügen der Info-Schildern erweitert werden, da die Bestandteile separat geliefert werden.

 Signaling system composed of curved aluminum plates and side covers. Available in 3 different widths. This system allows the composition of curved wall directories according to customer need. The components of this system are supplied separately.

 Panneaux directionnels en aluminium. Les lames sont disponibles en couleur argentée et en trois hauteurs différentes. Accessoires vendus séparément.

 Sistema de sinalização composto por placas de alumínio curvas e tampas laterais. Disponível em 3 larguras distintas. Este sistema permite a composição de directórios curvos para parede, segundo a necessidade do cliente. Os componentes deste sistema fornecem-se separadamente.

 Sistema de señalización compuesto por placas de aluminio curvas y tapas laterales. Disponible en 3 anchos distintos. Este sistema permite la composición de directorios de pared curvos según la necesidad del cliente. Los componentes de este sistema se suministran por separado.

Aluminium sign profile

 Alu-profil. Preis pro laufendem Meter (Inkl. Abdeckschutz aus Kunststoff).

 Directory plate. Price for linear meter. (Includes plastic protector).

 Plaque de direction. Prix au mètre linéaire. (Protection en plastique incluse).

 Placa de directório. Preço por metro linear (Inclui plástico protector).

 Placa de directorio. Precio por metro lineal (Incluye plástico protector).

10.224	60mm	
10.225	90mm	
10.226	140mm	



Profile Cut

 Meterpreis.

 Plastic Endcaps.

 Coupe unitaire.

 Corte unitário.

 Corte unitario.

10.233		
--------	--	--

Accessories - Plastic Endcaps

 Nylon - Abschlusskappen.

 Plastic Endcaps.

 Bouchon Nylon.

 Tampas de Nylon.

 Tapas Nylon.



60mm profiles

10.227		x10 	
10.230		x10 	

90mm profiles

10.228		x10 	
10.231		x10 	

140mm profiles

10.229		x10 	
10.232		x10 	

Straight Flag Sign

Zusammengesetztes System aus doppelseitigen Aluminium Profilen zur Wandbefestigung, für beidseitige Beschriftung. Lieferung als komplettes Set. Set enthält:

- Doppelseitige Aluminium Profile.
- Wandhalterung.
- Seitliche Abschlusskappen.

*Anwendung: innenraum. Für Fluchtweg-/Brandschutz-/Raumkennzeichnungen.

*Materialempfehlung: digitaldrucke, vinyl-display, etc.

*Befestigung: mittels schrauben. Schnelle und einfache Montage. Befestigungsschrauben nicht enthalten.

System composed of double-sided aluminum plates for fixing on the wall, with dual signage. Supplied in complete kits. Content:

- Double-sided aluminum plates.
- Fixing bracket.
- Plastic endcaps.

* Indoor use: corridors, office building, comercial centres, etc.

* Recommended materials: vinyl cutting and digital printing.

* Application: with screws. Quick and easy assembly.

Screws not included.

Système composé de plaques d'aluminium double face à fixer au mur qui permet une double signalisation. On les fournit en jeux complets. Contenu:

- Plaque d'aluminium double face.
- Support de fixation.
- Bouchons latéraux.

*Utilisation: à l'intérieur, toilettes, coins, etc.

* Matières recommandées: vinyle de coupe et impression digitale.

*Application: au moyen de vis. Montage facile et rapide. Vis non inclus.

Sistema composto de placas de alumínio de dupla face para fixar à parede, com dupla sinalização. Fornece-se em kits completos. Conteúdo:

- Placas de alumínio dupla face.
- Suporte de fixação.
- Tampas laterais.

*Uso: interiores, WC, esquinas, etc.

*Materiais recomendados: vinil de corte e impressão digital.

*Aplicação: mediante parafusos. Montagem fácil e rápida.

Impressão e parafusos não incluídos.

Sistema compuesto de placas de aluminio a doble cara para fijar a pared, con señalización doble. Se suministra en kits completos. Contenido:

- Placas de aluminio a doble cara.
- Soporte de fijación.
- Tapas laterales.

*Uso: interior. Aseos, esquinas, etc.

*Materiales recomendados: vinilo de corte e impresión digital.

*Aplicación: mediante tornillos. Fácil y rápido montaje.

Tornillería no incluida.



Install explanation

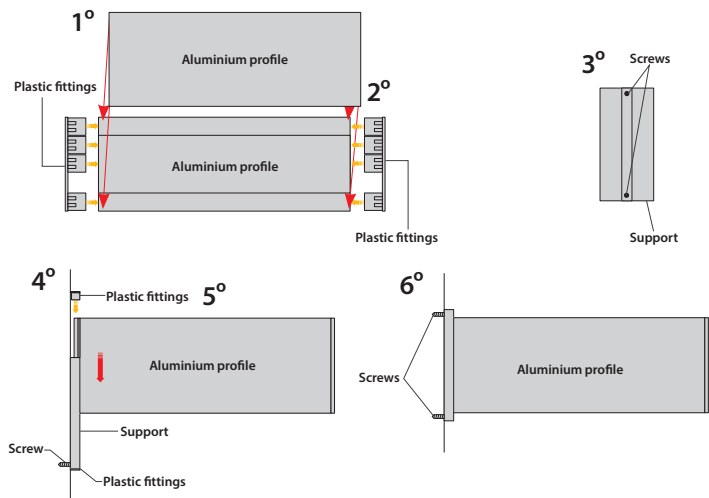

Installationsanleitung:

1. Fügen Sie die beiden Aluminium Profile zusammen.
2. Stecken Sie die Kunststoff-Abschlusskappen auf die Profelseiten.
3. Bohren Sie 2 Löcher in die Wandhalterung und Wand.

4. Schrauben Sie den unteren Teil der Halterung an die Wand und kleben Sie die Abschlusskappe auf.
5. Stecken Sie die Aluminium Profile in die Halterung. (s. Abb.)
6. Schrauben Sie den oberen Teil der Halterung an und kleben Sie die Abschlusskappe auf.

Install explanation:

1. Join the aluminium profiles.
2. Place the plastic caps.
3. Make 2 holes in the ends of the support and fix.

4. Screw the bottom of the bracket to the wall and attach the lid.
5. Connect the aluminum profiles as in the image.
6. Screw the top of the bracket and attach the lid.

Installation:

1. Assembler les profils en aluminium.
2. Insérer les bouchons en plastique.
3. Faire 2 trous dans les extrémités du support pour la fixation.

4. Visser la partie inférieure du support au mur et coller le bouchon.
5. Fixer les profils en aluminium au support comme sur l'image
6. Visser la partie supérieure et placer le bouchon.

Instalação:

1. Unir os perfis de alumínio.
2. Colocar as tampas de plástico.
3. Fazer 2 furos nos extremos do suporte para fixação.

4. Aparafusar a parte inferior do suporte à parede e colar a tampa.
5. Juntar os perfis de alumínio como na imagem.
6. Aparafusar a parte superior e colocar a tampa.

Instalación:

1. Unir los perfiles de aluminio.
2. Colocar las tapas de plástico.
3. Hacer 2 agujeros en los extremos del soporte y fijar.

4. Atornillar la parte inferior del soporte a la pared y pegar la tapa.
5. Acoplar los perfiles de aluminio al soporte como en la imagen.
6. Atornillar la parte superior del soporte y pegar la tapa.

15.685	220x90mm	
15.686	320x90mm	
15.687	220x124mm	
15.688	320x124mm	
15.689	420x124mm	
15.690	150x150mm	
15.691	220x150mm	
15.692	320x150mm	
15.693	420x150mm	

Curve Flag Sign

 Zusammengesetztes System aus konvex gewölbten Aluminium Profilen zur Wandbefestigung, für beidseitige Beschriftung in Standard Formaten. Lieferung als komplettes Set. Set enthält:

- Doppelseitige Aluminium Profile. *Anwendung: innenraum. Für Fluchtweg-/ Brandschutz-/ Raumkennzeichnungen.
- Wandhalterung, seitliche *Befestigung: mittels schrauben.
- Abschlusskappen und Kunststoff * Schnelle und einfache Montage. Befestigungsschrauben nicht enthalten.
- Abdeckschutz. *Materialempfehlung: digitaldrucke, vinyl-display etc.

 Curve flag sign. Aluminium double-sided flag wall. Mount any projected wall sign with screws. Complete kits. Includes:

- Aluminum double-sided profile. * Indoor use: office building, shops, public places, etc.
- Aluminium fitting. * Easy and quick to assemble. Screws not included.
- Plastic endcaps. * Application: au moyen de vis.
- Transparent sleeve. Montage facile et rapide. Vis non incluses.

 Système de signalisation composé de plaques courbés double face, en aluminium. Dimensions standard. Jeux complet fournit. Contenu:

- Plaque d'aluminium double face. * Utilisation: à l'intérieur, toilettes, coins, etc.
- Support de fixation. * Matières recommandées: vinyle de coupe et impression digitale.
- Bouchons latéraux. * Application: au moyen de vis.
- Plastique de protection. Montage facile et rapide. Vis non incluses.

 Sistema de sinalização composto de placas curvas de alumínio de dupla face em medidas standar. Fornece-se em kits completos. Conteúdo:

- Placas de alumínio dupla face. * Uso: interiores, WC, esquinas, etc.
- Suporte de fixação. * Materiais recomendados: vinil de corte e impressão digital.
- Tampas Laterais. * Aplicação: mediante parafusos. Montagem fácil e rápida. Parafusos não incluídos.
- lástico protector. * Aplicação: mediante parafusos. Montagem fácil e rápida. Parafusos não incluídos.

 Sistema de señalización compuesto de placas de aluminio curvo a doble cara en medidas estándar. Se suministra en kits completos. Contenido:

- Placas de aluminio a doble cara. * Uso: interior. Aseos, esquinas, etc.
- Soporte de fijación. * Materiales recomendados: vinilo de corte e impresión digital.
- Tapas laterales. * Aplicación: mediante tornillos.
- Plástico protector. Fácil y rápido montaje. Tornillería no incluida.

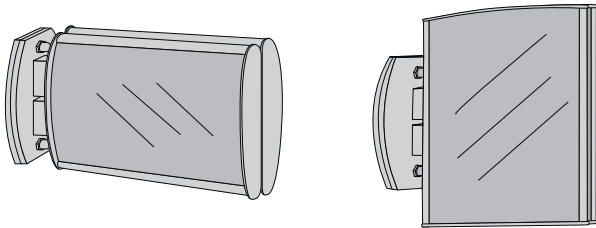

Curve Flag Sign (with separator)

15.619	150x115mm	
15.620	180x115mm	
15.621	220x115mm	
15.625	150x150mm	
15.626	180x150mm	
15.622	115x150mm	
15.623	115x180mm	
15.624	115x220mm	
15.627	150x180mm	
15.628	150x200mm	

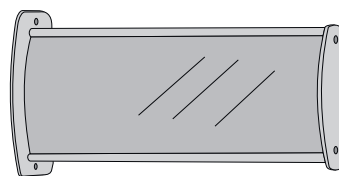

Curve Flag Sign (direct to wall)

15.629	220x115mm	
15.630	280x115mm	
15.631	300x115mm	
15.632	150x150mm	
15.633	250x150mm	

Install explanation (with separator)

Installationsanleitung:

1. Verschrauben Sie die beiden Aluminium Profile miteinander.
2. Stecken Sie die Kunststoff Abschlusskappen auf die Profileseiten.
3. Bringen Sie den transparenten Abdeckschutz auf den Alu-Profilen an.
4. Stecken Sie das fertig zusammengesetzte Profil auf die Wandhalterung.
5. Schrauben sie das Fahnschild an den gewünschten Platz.

Install explain:

1. Attach the two aluminum profiles with screws.
2. Placing the side covers.
3. Put the transparent sheets on the aluminum profiles.
4. Attach the fixing supports to profiles.
5. Place screws in the right place.

Installation:

1. Joindre les profils d'aluminium en utilisant des vis.
2. Placer les couvertures latérales.
3. Placer les lames transparentes sur les profils d'aluminium.
4. Joindre les profils au support de fixation.
5. Placer avec des vis dans le lieu choisi.

Instalação:

1. Unir os perfis de alumínio mediante parafusos.
2. Colocar as tampas laterais.
3. Colocar as lâminas transparentes sobre os perfis de alumínio.
4. Unir os perfis ao suporte de fixação.
5. Colocar com parafusos no lugar apropriado.

Instalación:

1. Unir los dos perfiles de aluminio mediante tornillos.
2. Colocar las tapas laterales.
3. Poner las láminas transparente sobre los perfiles de aluminio.
4. Unir Los perfiles al soporte de fijación.
5. Colocar con tornillos en el lugar apropiado.

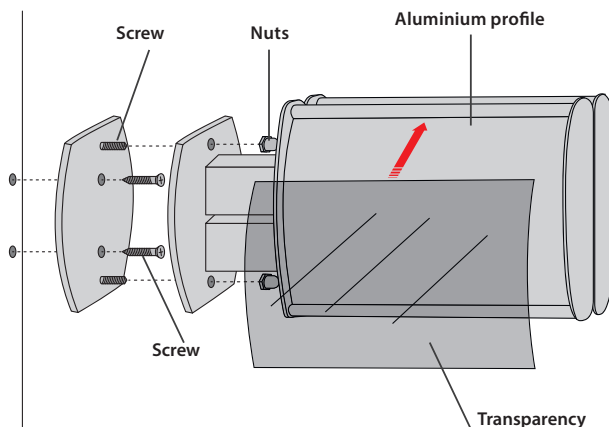

Install explanation (direct to wall)

Installationsanleitung:

1. Fügen Sie die beiden Aluminium Profile zusammen.
2. Stecken Sie die Kunststoff-Abschlusskappe auf das Profil.
3. Schieben Sie den transparenten Abdeckschutz in das Aluminium Profil.
4. Stecken Sie die Kunststoff Abschlusskappe auf das Profil und verschrauben Sie sie miteinander.
5. Schrauben sie das Fahnschild an den gewünschten Platz.

Install explain:

1. Join the aluminum profiles.
2. Place the plastic cover and screw.
3. Put the transparent sheet on the profiles.
4. Attach the fixing supports to profiles.
5. Place screws in the right place.

Installation:

1. Joindre les profils d'aluminium.
2. Placer les bouchons en plastique et visser.
3. Placer la lame transparente sur les profils.
4. Joindre les profils avec le support en plastique.
5. Placer avec des vis à l'endroit choisi.

Instalação:

1. Unir os perfis de alumínio.
2. Colocar a tampa de plástico e aparafusar.
3. Colocar a lâmina transparente sobre os perfis.
4. Unir os perfis com o suporte de plástico.
5. Colocar com parafusos no lugar apropriado.

Instalación:

1. Unir los perfiles de aluminio.
2. Colocar la tapa de plástico y atornillar.
3. Poner la lámina transparente sobre los perfiles.
4. Unir los perfiles con el soporte de plástico.
5. Colocar con tornillos en el lugar apropiado.

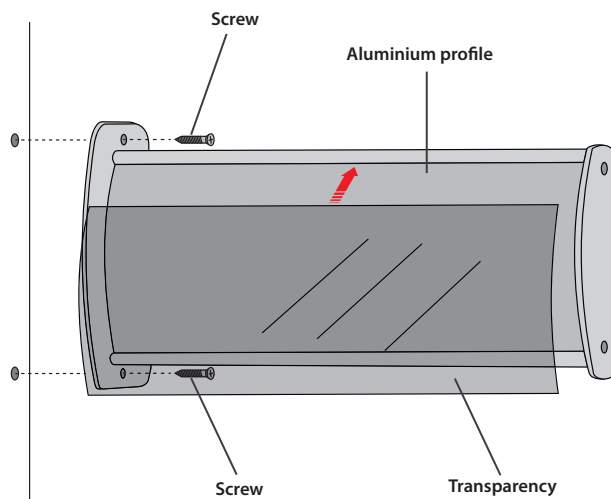

Curved Desk Sign

 Tischaufsteller aus 2 Aluminium Profilen mit gewinkeltem Fuß. Lieferung als komplettes Set. Schnelle und einfache Montage. Set enthält:

- 2 konvex gewölbte Aluminium Profile.
- Seitliche Abschlusskappen mit grauer Fußstütze.
- Kunststoff Abdeckschutz.
- * Anwendung: innenraum. Für schreibische, rezeptionen etc.
- * Schnelle und einfache Montage.

 Curve desk sign. aluminium table top signs. Complete kits. Material: Aluminium, plastic parts. Includes:

- Main faceplate/arc aluminium metal alloy.
- Transparent sleeve.
- Plastic fitting.
- * Indoor use: Tabletop, desk, counters, receptions, etc.
- * Easy and fast to assemble.

 Système composé par deux plaques courbées d'aluminium et supports spéciaux qui permettent une inclination des plaques sur un bureau de façon à identifier et informer. Fourni en kits complets. Contenu:

- Deux plaques courbées d'aluminium.
- Bouchons latéraux gris.
- Plastique de protection.
- * Utilisation: À l'intérieur, bureaux, réceptions, etc.
- * Montage facile et rapide.

 Sistema composto de duas placas de alumínio curvas, mais suportes especiais que permitem uma colocação inclinada sobre uma secretária de um modo identificativo e informativo. É fornecido em kits completos. Conteúdo:

- Duas placas de alumínio curvas.
- Tampas laterais cinzentas de posicionamento.
- Plástico protector.
- * Uso: Interiores. Escritórios, recepções, etc.
- * Montagem fácil e rápida.

 Sistema compuesto de dos placas de aluminio curvo más soportes especiales que permiten su colocación inclinada sobre un escritorio a modo identificativo o informativo. Se suministra en kits completos. Contenido:

- 2 placas de aluminio curvos.
- Tapas laterales de posicionamiento grises.
- Plástico protector.
- * Uso: Interior. Escritorios, recepciones, etc.
- * Fácil y rápido montaje.

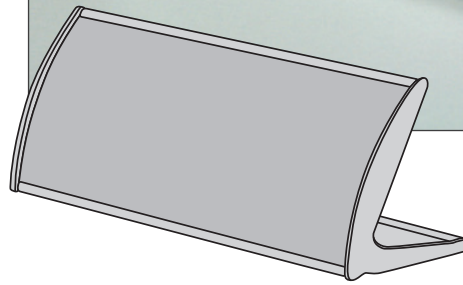

Install explanation

 Installationsanleitung:

1. Schieben Sie den transparenten Abdeckschutz in das Aluminium Profil.
2. Stecken Sie die Kunststoff Abschlusskappen auf die Profilseiten.

 Install explanation:

1. Introduce the transparent film into the aluminium surface.
2. Introduce the plastic covers on the sides.

 Installation:

1. Introduire la lame transparente dans la surface d'aluminium.
2. Introduire les bouchons de plastique sur les côtés.

 Instalação:

1. Introduzir a lâmina transparente na superfície de alumínio.
2. Introduzir as tampas de plástico nos laterais.

 Instalación:

1. Introducir la lámina transparente en la superficie de aluminio.
2. Introducir las tapas de plástico en los laterales.

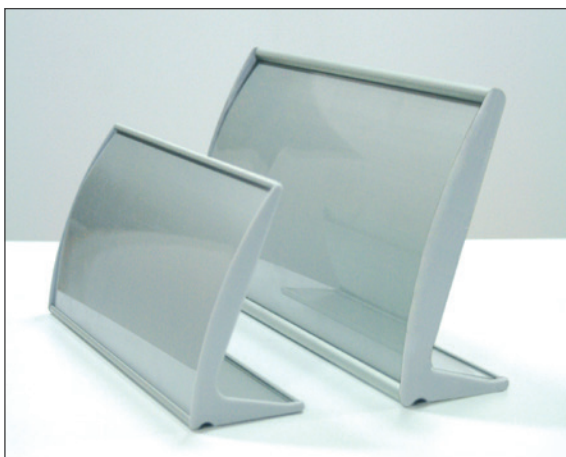
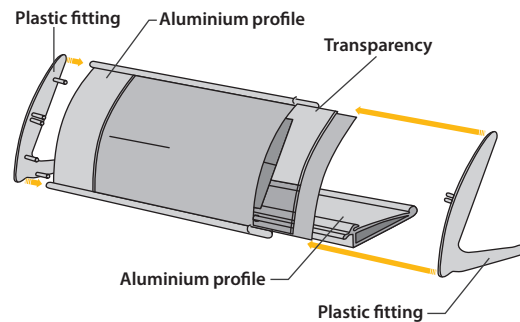

15.599	180x115mm	
15.600	200x115mm	
15.601	250x115mm	
15.602	350x115mm	
15.603	300x150mm	

Desk Sign Steel Support

Tischaufsteller bestehend aus zwei verchromten oder vergoldeten Stützfüßen aus Stahl. Lieferumfang 2Stück. Schnell und einfach aufgestellt.

*Anwendung: innenraum. Für schreibische, rezeptionen etc.
*Schnelle und einfache Montage.

Desk sign steel support. Gold or chrome finishing. Includes two steel supports. Material: Steel.

* Indoor use: counters, desk receptions, etc.
* Easy and quick to assemble.

Système composé par deux pièces d'acier qui permettent de mettre une affiche sur le bureau de façon à identifier et informer.

*Utilisation: À l'intérieur, bureaux, réceptions, etc.
* Facile et rapide à monter.

Sistema composto por duas peças de aço as quais permitem a colocação de um cartaz sob a secretária de modo identificativo e informativo.

*Uso: Interiores. Escritórios, recepções, etc.
*Montagem fácil e rápida.

Sistema compuesto de dos piezas de acero que permite la colocación de un cartel sobre un escritorio a modo identificativo e informativo.

*Uso: Interior. Escritorios, recepciones, etc.
*Fácil y rápido montaje.



15.567	80x8mm	x2		
15.568	80x8mm	x2		
15.569	80x8mm	x2		
15.570	80x8mm	x2		

Acrylic Data Frame

Acryl-System. Beinhaltet zwei Acryl-Platten 3mm Dicke. Einfach und schnell zu montieren. Verwendung im Innenbereich: Büro, Gebäude, Geschäfte, usw. Material: Acryl und Aluminium.

Simple and versatile system signaling. Easy to assemble. Interior usage: office buildings, shops, etc. Acrylic and aluminium.

Système composé de 2 plaques en acrylique de 3mm. Facile et rapide à assembler. Utilisation intérieure : bureau, etc. Matériel : acrylique et aluminium

Sistema de sinalização simples e versátil. Fácil e simples de montar. Uso interior: escritório, edifícios, lojas, etc. Acrílico e alumínio.

Sistema de señalización simple y versátil. Fácil montaje. Uso interior: Oficinas, edificios, tiendas, etc... Acrílico y aluminio.



Ref. 15.208



Ref. 15.207



15.208	66x66mm	
15.207	195x60mm	

WALL MOUNTING PANEL SUPPORTS

10

Wall Mounting Aluminium Panel Supports

DE Dekorativer Abstandshalter aus Aluminium zur Wandbefestigung von Schildern. In-/Outdoor Bereich. Für verschiedene Formate und Materialtypen geeignet.

UK These wall mounting panel supports are available in a range of finishings to complement your display. Available in different colours. Use: indoor/outdoor. Material: Aluminium.

FR Système de fixation d'affiches au mur avec deux pièces en acier qui permettent de séparer le mur de l'affiche et de protéger les vis.

PT Sistema de fixação à parede, de cartaz, com duas peças de alumínio, que permitem a separação da parede e a protecção dos parafusos para lhe dar uma melhor finalização. Disponível em várias cores.

ES Sistema de fijación a pared de cartelería mediante dos piezas de aluminio que permiten aislarlo de la pared y a su vez proteger los tornillos utilizados para darle un mejor acabado.



Ø 13mm

15.528

15.532

15.536

15.540 13x13mm x4

15.529

15.533

15.537

15.541 13x19mm x4

Ø 19mm

15.530

15.534

15.538

15.542 19x25mm x4

Ø 25mm

15.531

15.535

15.539

15.543 25x30mm x4

Screw Covers

DE Dekorative Abdeckkappen für Abstandshaltern. Lieferumfang: 1 Abdeckkappe mit Mutter. Für In-/Outdoor Bereich geeignet.

UK System that involves placing a ring or trim over the heads of the screws that will be exposed for covering them. Thus, we are going to decorate the surface of the piece that will be mounted.

FR Système qui constitue à placer des anneaux ou des séparateurs décoratifs sur les têtes des vis qui sont visibles, en les couvrant. De cette façon on peut aussi décorer la surface de la pièce que nous allons monter.

PT Sistema que consiste em colocar umas anilhas ou separadores decorativos sobre as cabeças dos parafusos que ficam visíveis. Desta forma também se decora a superfície da peça que vamos montar.

ES Sistema que consiste en colocar unas anillas o embellecedores sobre las cabezas de los tornillos que quedan al descubierto para taparlos. De esta forma también se decora la superficie de la pieza que vamos a montar.

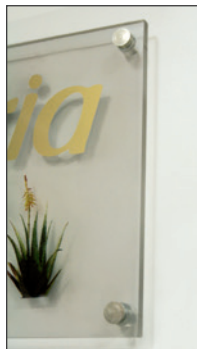

15.544 Ø 15mm x4

15.545 Ø 19mm x4

15.546 Ø 25mm x4

15.547 Ø 15mm x4

15.548 Ø 19mm x4

15.549 Ø 25mm x4

WALL MOUNTING PANEL SUPPORTS

Wall Mounting Panel Supports

 Dekorativer Abstandshalter aus Aluminium zur Wandbefestigung von Schildern. In-/Outdoor Bereich. Für verschiedene Formate und Materialtypen geeignet.

 Wall mounting through hole panel supports. These wall mounting panels support are available in gold or chrome colour. Use: indoor/outdoor. Material: Steel.

 Système de fixation d'affiches au mur avec deux pièces d'acier qui permettent la séparation entre le mur, et aussi la protection des vis Utilisées. Ce qui permet d'obtenir une meilleure finition. Disponible en couleur doré et chromé et en divers dimensions.

 Sistema de fixação à parede, de cartaz, com duas peças de aço que permitem a separação da parede e a protecção dos parafusos para lhe dar uma melhor finalização. Disponível em dourado e cromado em várias medidas.

 Sistema de fijación a pared de cartelería mediante dos piezas de acero que permiten aislarlo de la pared y a su vez proteger los tornillos utilizados para darle un mejor acabado. Disponible en color dorado y cromado en varias medidas.

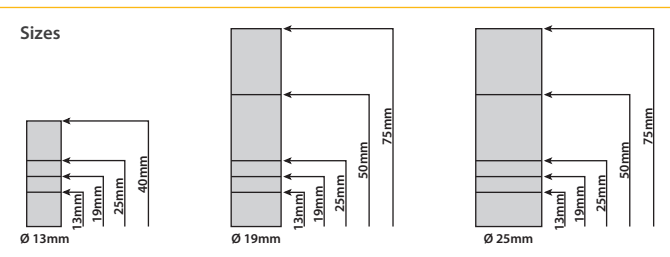
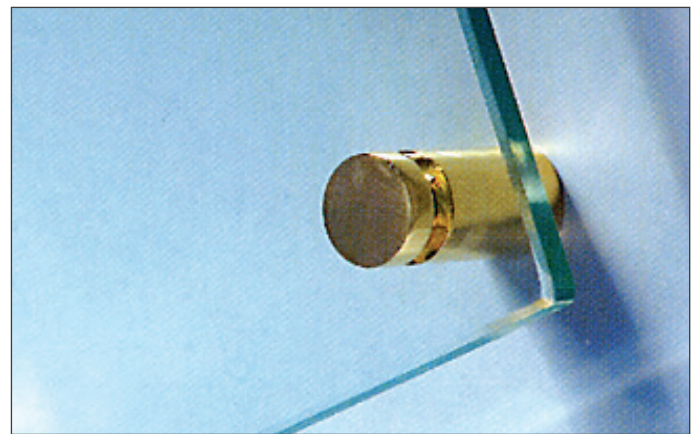













Ø 13mm

15.500	13x13mm	x4 	<input type="checkbox"/>	
15.501	13x19mm	x4 	<input type="checkbox"/>	
15.502	13x25mm	x4 	<input type="checkbox"/>	
15.503	13x40mm	x4 	<input type="checkbox"/>	
15.504	13x13mm	x4 	<input type="checkbox"/>	
15.505	13x19mm	x4 	<input type="checkbox"/>	
15.506	13x25mm	x4 	<input type="checkbox"/>	
15.507	13x40mm	x4 	<input type="checkbox"/>	

Ø 19mm

15.508	19x13mm	x4 	<input type="checkbox"/>	
15.509	19x19mm	x4 	<input type="checkbox"/>	
15.510	19x25mm	x4 	<input type="checkbox"/>	
15.511	19x50mm	x4 	<input type="checkbox"/>	
15.512	19x75mm	x4 	<input type="checkbox"/>	
15.513	19x13mm	x4 	<input type="checkbox"/>	
15.514	19x19mm	x4 	<input type="checkbox"/>	
15.515	19x25mm	x4 	<input type="checkbox"/>	
15.516	19x50mm	x4 	<input type="checkbox"/>	
15.517	19x75mm	x4 	<input type="checkbox"/>	

Ø 25mm

15.518	25x13mm	x4 	<input type="checkbox"/>	
15.519	25x19mm	x4 	<input type="checkbox"/>	
15.520	25x25mm	x4 	<input type="checkbox"/>	
15.521	25x50mm	x4 	<input type="checkbox"/>	
15.522	25x75mm	x4 	<input type="checkbox"/>	
15.523	25x13mm	x4 	<input type="checkbox"/>	
15.524	25x19mm	x4 	<input type="checkbox"/>	
15.525	25x25mm	x4 	<input type="checkbox"/>	
15.526	25x50mm	x4 	<input type="checkbox"/>	
15.527	25x75mm	x4 	<input type="checkbox"/>	

Wall Mounting Aluminium Panel Support

Wand-Halterung für die Befestigung von Beschilderungen. Farbe: Silber. Material: Aluminium. Beinhaltet:

- Stand-Offs mit 6 LED-Lampen.
- Stromversorgung.
- Plug und Leitungen.

Wall mounting aluminium panel support for fixing signs. Colour: silver. Material: Aluminium. Includes:

- Stand-Offs with 6 LED bulbs.
- Power supply.
- Plug and wires.

Système de signalisation à LED pour fixer au mur ou à une étagère par le moyen de pinces en aluminium composées de:

- LED
- Transformateur.
- Câble de connexion.

Separadores de pared de cor cinza. Material: Alumínio. Inclui:

- Perfil com 6 leds.
- Alimentador.
- Ficha e cabo.

Sistema de señalización con luz (LED) para fijación a pared de cartelería mediante dos piezas de aluminio compuesto por:

- Separador con Led.
- Convertidor de corriente.
- Cables de conexión.

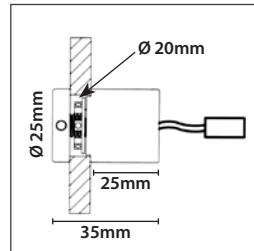

15.724 25x25mm x4

Sign System with LED Light

LED Leiste zur Beleuchtung von Beschilderungen. Lieferumfang:

- LEDs weiss.
- Netzteil.

*Verbindungskabel geeignet für Glas und Metacrylat bis zu einer Stärke von 8mm.

Sign System with LED Light Sign system with LED lights. Includes:

- Satin Aluminum Profile.
- Led de couleur blanche à l'intérieur.
- Power supply.

• Plug and wires.
*Suitable for glass or acrylic up to 8mm of thickness.

Système de signalisation avec lumière (LED) composé de:

- Profil en aluminium satiné.
- Led de couleur blanche à l'intérieur.
- Convertisseur de courant.

*Câble de connexion.
*Fait pour les vitres en cristal ou en méthacrylique de 8mm d'épaisseur.

Sistema de sinalização com leds, composto por:

- Perfil de alumínio satinado.
- Transformador.

*Recomendado para acrílico ou vidro até 8 mm.

Sistema de señalización con luz (LED) compuesto por:

- Perfil de Aluminio Satinado.
- Leds color blanco en su interior.
- Convertidor de corriente.

• Cables de conexión.
*Apto para cristal o metacrilato de hasta 8mm. de espesor.

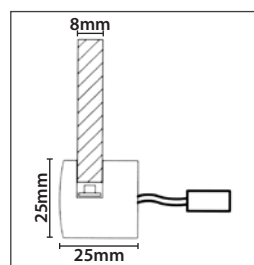





15.725 120mm 9 LEDs

15.726 180mm 12 LEDs

15.727 280mm 21 LEDs

CUBE SYSTEM

Cube System

-  Verbinder aus Stahl für Regalsysteme oder Displays. In 5 Farben verfügbar.
-  Panel support for shelves or posters using a piece of steel. Available in 5 colors.
-  Système de fixation d'étagères ou de bibliothèque par le moyen de pièces en acier. 5 couleurs disponibles. Pack de 4 unités.
-  Sistema de fixação de estantes ou cartazes mediante uma peça de aço. Disponível em 5 cores.
-  Sistema de sujeción de estanterías o cartelería mediante una pieza de acero. Disponibles en 5 colores.

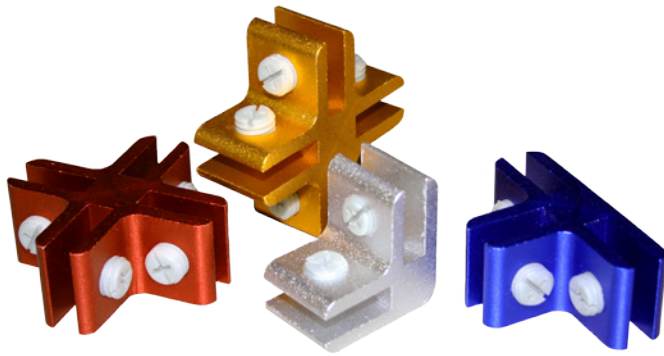
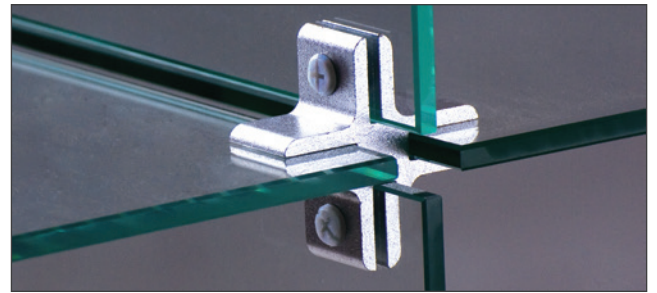

15.182 

15.183 

15.184 

15.185 

15.186  x4 

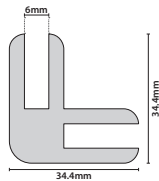

15.187 

15.188 

15.189 

15.190 

15.191  x4 

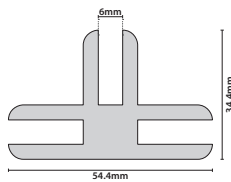

15.192 

15.193 

15.194 

15.195 

15.196  x4 

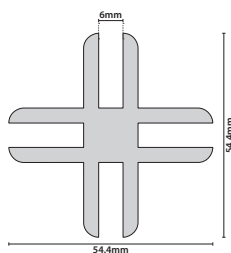
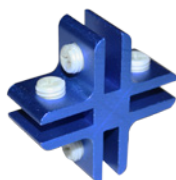

PANEL SUPPORT

10

Panel Support

Wandhalter aus Stahl für Regalböden oder Grafiken. Halter wird an die Wand geschraubt. Verfügbar in Gold oder verchromt.

Panel support for shelves or posters using a bolted piece of steel to the wall. Available in gold and chrome colors.

Système de fixation d'étagères par des pièces en acier à fixer au mur. Pièces disponibles chromée ou dorée.

Sistema de suspensão de estantes ou cartazes com uma peça aparafusada à parede. Disponíveis em dourado e cromado.

Sistema de sujeción de estanterías o cartelería mediante una pieza de acero atornilladas a la pared. Disponibles en dorado y cromado.

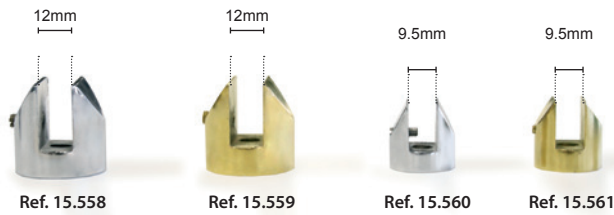

15.558	35x35mm	12mm	x4		
15.560	25x25mm	9.5mm	x4		
15.559	35x35mm	12mm	x4		
15.561	25x25mm	9.5mm	x4		

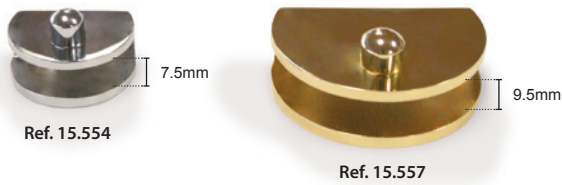
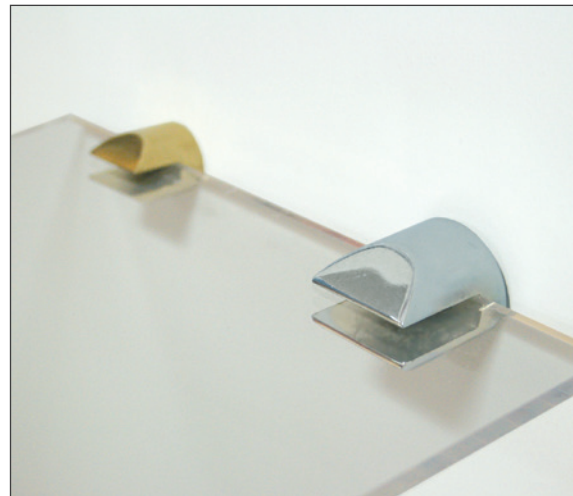

15.554	30mm	7.5mm	x2		
15.555	50mm	9.5mm	x2		
15.556	30mm	7.5mm	x2		
15.557	50mm	9.5mm	x2		



15.562	80x28mm		x4		
15.563	50x25mm		x4		



Glass System Sign

Acryl-System. Beinhaltet zwei Acryl-Platten 3mm Dicke. Einfach und schnell zu montieren. Verwendung im Innenbereich: Büro, Gebäude, Geschäfte, usw. Material: Acryl und Aluminium.

Acrylic Signaling System. Includes two acrylics pieces of 3mm thick. Easy to assemble. Indoor Use: office buildings, shops, etc..

Système composé de 2 plaques en acrylique de 3mm. Facile et rapide à assembler. Utilisation intérieure : bureau, etc. Acrylique et aluminium.

Sistema de sinalização em acrílico. Inclui dois acrílicos com 3 mm de espessura. Fácil e simples de montar. Uso interior: escritório, edifícios, lojas, etc. Material: Acrílico e alumínio.

Sistema de señalización en acrílico. Incluye dos acrílicos de 3mm de grosor. Fácil montaje. Uso interior: Oficinas, edificios, tiendas, etc... Material: Acrílico y aluminio.

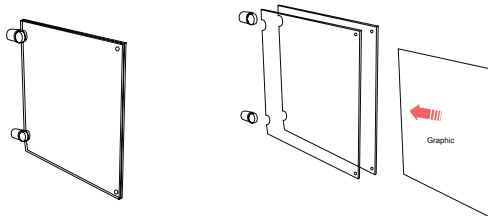

15.203	297x120mm	<input type="checkbox"/>	
15.204	120x297mm	<input type="checkbox"/>	
15.205	210x297mm	<input type="checkbox"/>	
15.206	210x210mm	<input type="checkbox"/>	

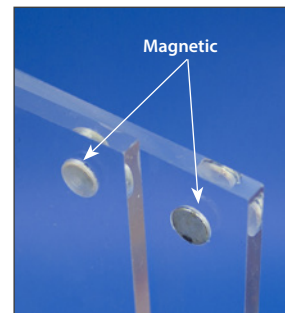
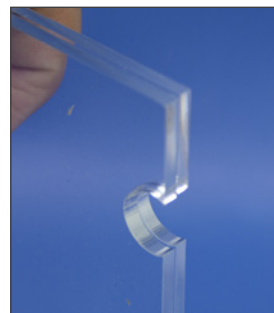
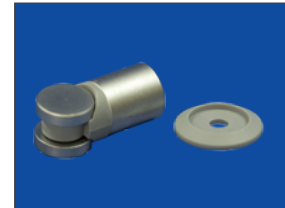
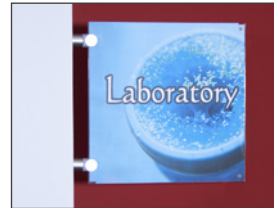

"Square" Side Grip

Abstandhalter für Schilder aus Kunststoff oder Glas mit Materialstärke von 10mm. Verfügbar in Gold oder verchromt.

These fixings are mounted at the side. They hold materials up to 10mm thick on the vertical or horizontal edge. Chrome or gold colour. For indoor and outdoor use. Material: Steel.

Système de séparation d'affiches qui permet la fixation de matériaux de 10mm d'épaisseur. Disponible en doré ou chromé.

Sistema de separação de cartazes de 10mm de espessura. Disponíveis em dourado e cromado.

Sistema de separación de cartelaría, que permite fijar en su interior materiales de 10mm de espesor. Disponibles en dorado y cromado.

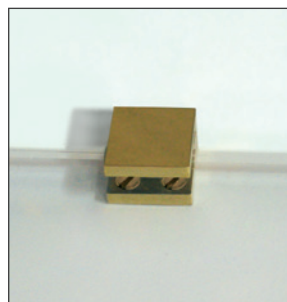
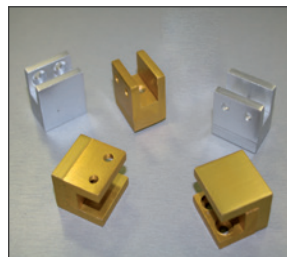

Side Grip

Abstandhalter für Schilder aus Kunststoff oder Glas mit Materialstärke von 8 bis 10mm. Verfügbar in Gold oder verchromt.

These fixings are mounted at the side. The materials, like glass, mirrors, leaded glass or another can easily mounted on the wall without drilling any holes. They hold material up to 8 to 10mm thick. for indoor and outdoor use. Material: Steel.

Système de séparation d'affiches qui permet la fixation de matériaux de 8mm à 10mm d'épaisseur. Disponible en doré ou chromé.

Sistema de separação de cartazes de diferentes espessuras que podem ir de 8 a 10mm. Disponíveis em dourado e cromado.

Sistema de separación de cartelaría, que permite fijar en su interior materiales de 8 a 10mm de espesor. Disponibles en dorado y cromado.





15.564	25x25mm	x4	<input type="checkbox"/>	
15.565	25x25mm	x4	<input type="checkbox"/>	

15.550	20x25mm	x4	<input type="checkbox"/>	
15.551	20x30mm	x4	<input type="checkbox"/>	
15.552	20x25mm	x4	<input type="checkbox"/>	
15.553	20x30mm	x4	<input type="checkbox"/>	

Outdoor Sign

 Info-Leitsystem für den Outdoor Bereich in zwei Standard Formaten. Bestehend aus zwei Aluminium Pfosten und doppelseitige Aluminium Profile.

 Outdoor signage system in two standard measures, composed of two aluminum poles for ground mounting and aluminum sided for better viewing.

 Système de signalisation extérieur en 2 dimensions standard. Composé de 2 poteaux en aluminium à fixer au sol et des profils en aluminium double face.

 Sistema de sinalização exterior em duas medidas standar, composto por dois postes de alumínio para fixação ao solo e perfis de alumínio com dupla face para uma melhor visualização.

 Sistema de señalización exterior en dos medidas estándar, compuesto de dos postes de aluminio para fijación al suelo y perfiles de aluminio a doble cara para una mejor visualización.

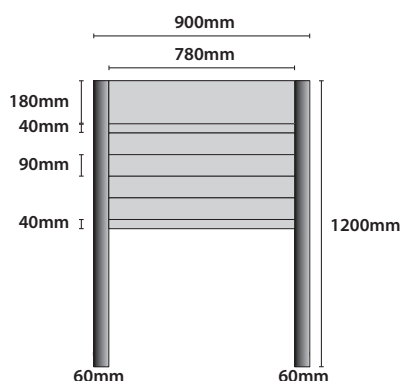

15.716 **900x1200mm**

 Bestehend aus:

- 2 aluminium posts 1200mm x Ø 60mm.
- 2 plastic post endcaps.
- 1 aluminium profile 180mm wide.
- 2 aluminium profiles 40mm wide.
- 4 aluminium profiles 90mm wide.

 Includes:

- 2 aluminium posts 1200mm x Ø 60mm.
- 2 plastic post endcaps.
- 1 aluminium profile 180mm wide.
- 2 aluminium profiles 40mm wide.
- 4 aluminium profiles 90mm wide.

 Composé par:

- 2 poteaux d'aluminium 1200x60mm de diamètre.
- 2 bouchons noirs pour poteaux de 60mm de diamètre.
- 1 profil d'aluminium de 180mm.
- 2 profils d'aluminium de 40mm.
- 4 profils d'aluminium de 90mm.

 Composto por:

- 2 Postes de alumínio de 1200x60mm de diâmetro.
- 2 Tapas negras para poste de 60mm de diâmetro.
- 1 perfil de alumínio de 180mm.
- 2 perfis de alumínio de 40mm.
- 4 perfis de alumínio de 90mm.

 Compuesto por:

- 2 Postes de aluminio de 1200x60mm de diámetro.
- 2 Tapas negras para poste de 60mm de diámetro.
- 1 perfil de aluminio de 180mm.
- 2 perfiles de aluminio de 40mm.
- 4 perfiles de aluminio de 90mm.

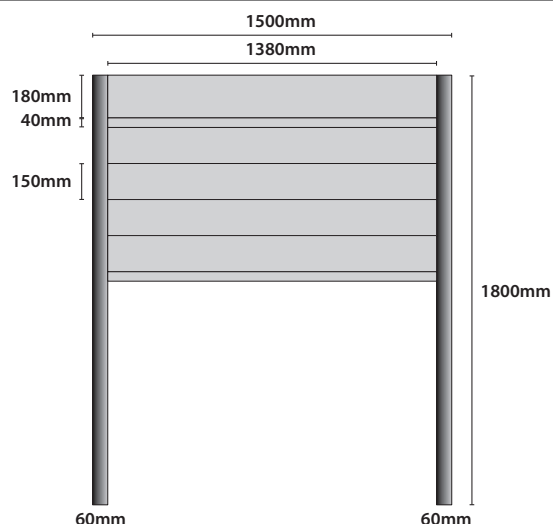

15.717 **1500x1800mm**

 Bestehend aus:

- 2 Aluminium Pfosten 1800mmx60mm Durchmesser.
- 2 schwarze Abschlusskappen für Pfosten mit 60mm Durchmesser.
- 1 Aluminium Profil 180mm.
- 4 Aluminium Profile 150mm.
- 2 Aluminium Profile 40mm.

 Includes:

- 2 aluminium posts 1800mm x Ø 60mm.
- 2 plastic post endcaps.
- 1 aluminium profile 180mm wide.
- 2 aluminium profiles 40mm wide.
- 4 aluminium profiles 90mm wide.

 Composé par:

- 2 poteaux d'aluminium 1800x60mm de diamètre.
- 2 bouchons noirs pour poteaux de 60mm de diamètre.
- 1 profil d'aluminium de 180mm.
- 4 profils d'aluminium de 150mm.
- 2 profils d'aluminium de 40mm.

 Composto por:

- 2 Postes de alumínio de 1800x60mm de diâmetro.
- 2 tampas pretas para poste de 60mm de diâmetro.
- 1 perfil de alumínio de 180mm.
- 4 perfis de alumínio de 150mm.
- 2 perfis de alumínio de 40mm.

 Compuesto por:

- 2 Postes de aluminio de 1800x60mm de diámetro.
- 2 Tapas negras para poste de 60mm de diámetro.
- 1 perfil de aluminio de 180mm.
- 4 perfiles de aluminio de 150mm.
- 2 perfiles de aluminio de 40mm.

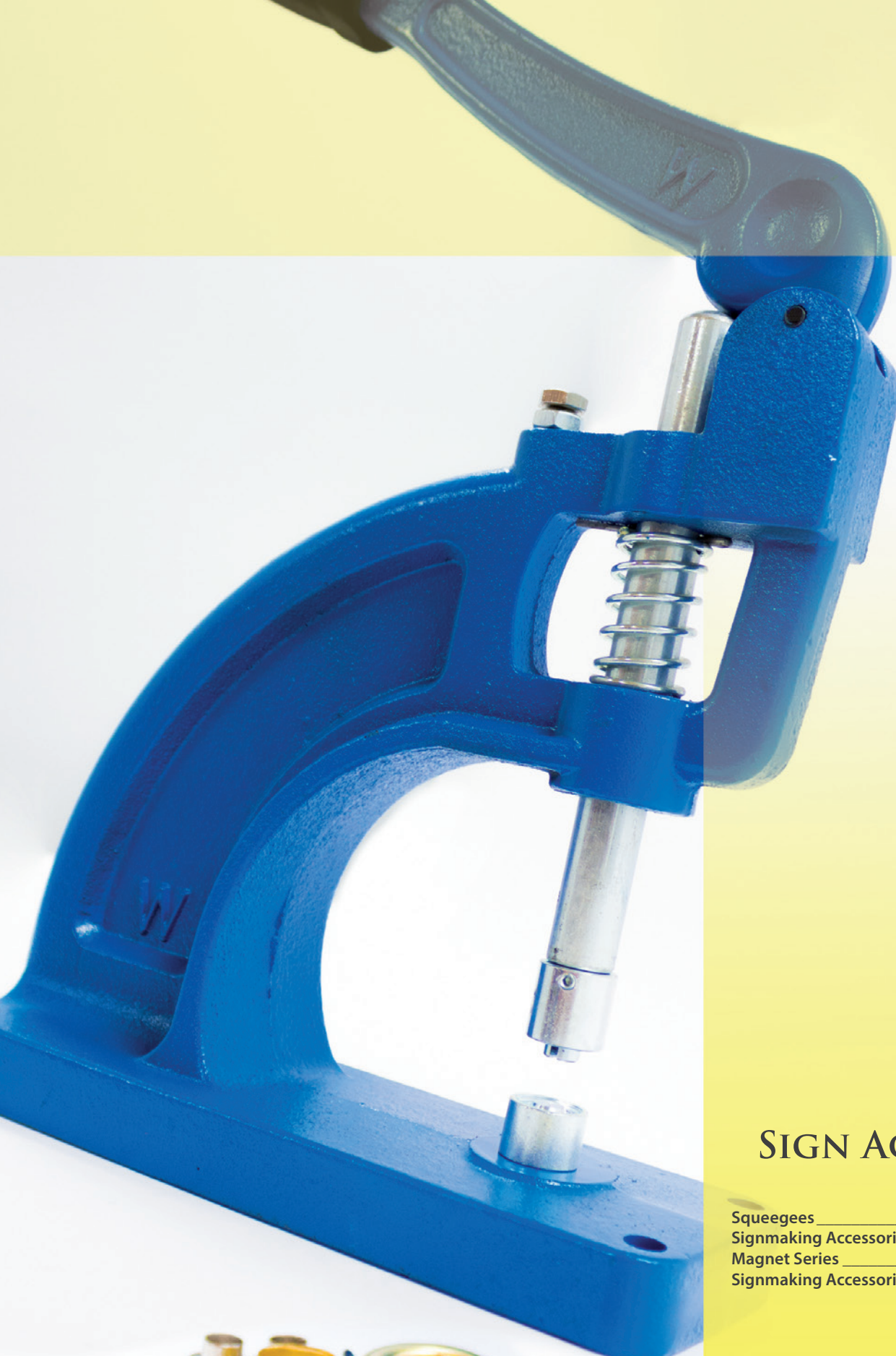

SIGN ACCESSORIES

Squeegees	342
Signmaking Accessories	343
Magnet Series	344
Signmaking Accessories	346

Squeegees

 Raket zum Auftragen Vinyl.

 Squeegees for applying vinyl.

 Raclette pour l'application de vinyles.

 Espátulas para aplicação de vinil.

 Rasquetas para la aplicación de vinilos.



16.012 100x70x13mm x10  

16.013 100x70x13mm x10  



16.003 100x70mm x10 

16.004 130x70mm x10 



16.014 130x70x13mm x10  

16.015 130x70x13mm x10  



16.005 100x70mm x10 



16.000 108x240mm x10 



16.001 60x135mm x10 







16.002 90x115mm x10 



16.006 20x150mm x10 





Application Roller

-  Rolle zum blasenfreien Verkleben von Folien.
-  Application Roller for vinyl.
-  Rouleau pour la mise en place de vinyles.
-  Rolo para aplicação de vinil.
-  Rodillo para la aplicación de vinilo.



16.009



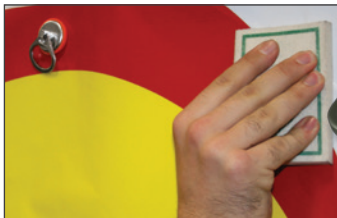

Magnetic Ring

-  Magnetring zur Unterstützung beim Verkleben von Folien.
-  Magnetic ring for fixing vinyl. Material: Steel.
-  Anneau magnétique pour fixation de vinyle.
-  Anel magnético para fixar vinil.
-  Anillo magnético para fijación de vinilo.



16.124





Magnetic Base

-  Magnet mit Griff zur Unterstützung beim Verkleben von Folien.
-  Magnetic base with knob. Material: Steel, plastic.
-  Base magnétique avec manche.
-  Base magnética com cabo.
-  Base magnética con mango.



16.125



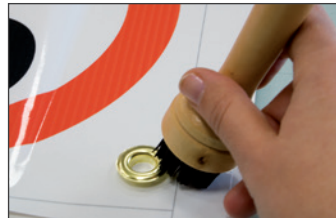

Rivet Brush

-  Nietenbürste mit harten Borsten und Holzgriff. Durch ihren Einsatz halten Folien besonders gut auf profilierten Untergründen, wie Ziegelsteinen, Beton und Putz. Auch zum Verkleben von Folien auf Fahrzeugen geeignet.
-  Wooden handle brush with stiff bristles which helps in applying vinyl on brick, cement, stucco, banners, etc. It is also used in the application of vehicle graphics.
-  Brosse de poils en nylon rigides avec manche, qui permet l'application de vinyle sur des briques, ciment, stuc, banners, etc. S'utilise également pour l'application de vinyles sur véhicules.
-  Pincel com cabo de madeira e cerdas rígidas que ajudam a aplicação de vinil a tijolo, cimento, estuque, banners, etc. Também é utilizado na aplicação de gráficos em veículos.
-  Cepillo de mango de madera con cerdas rígidas que ayuda en la aplicación de vinilo a ladrillo, cemento, estuco, banners, etc. También se utiliza en la aplicación de gráficos en los vehículos.



16.011

Suction Cup

-  Sauggriffe einfach, doppelt oder dreifach für den Transport von schweren Bauteilen. Einfache und schnelle Nutzung.
-  Simple, double or triple suction cups to facilitate the transport of heavy panels. Easy and quick to use.
-  Ventouses simples ou doubles o triples pour faciliter le transport de panneaux lourds.
-  Ventosas simples, duplas ou triplo para facilitar o transporte de painéis pesados. Fácil e rápido de usar.
-  Ventosas simples, dobles o triples para facilitar el transporte de paneles pesados. Fácil y rápido de usar.



16.016

Simple

Capacity 30kg



16.017

Double

Capacity 60kg



16.018

Triple

Capacity 120kg

Magnetic Insert Discs

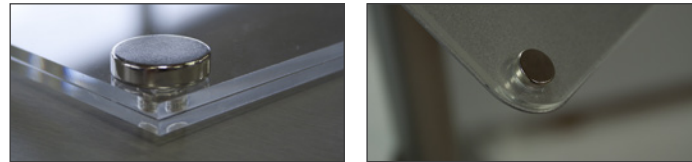
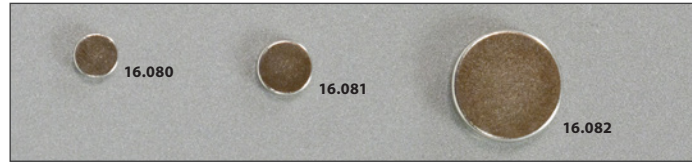
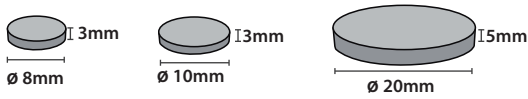

16.080	Ø8x3mm	x10		
16.081	Ø10x3mm	x10		
16.082	Ø20x5mm	x10		

Ferrite Magnetic Base

Ferrit-Magnetbasis. Material: Stahl / Ferrite.

Magnetic Base. Steel / Ferrite

Base magnétique en ferrite/acier.

Base magnética em aço e ferrite.

Base magnética. Acero / Ferrita.

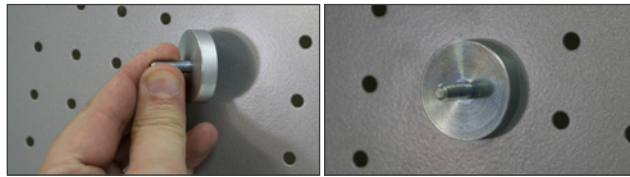
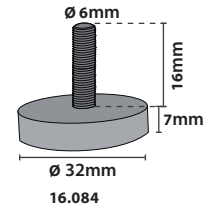
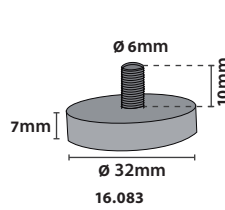

16.083	Base: Ø32x7mm Screw: Ø6x10mm	x10		
16.084	Base: Ø32x7mm Screw: Ø6x16mm	x10		

Neodymium Magnetic Base

Neodym-Magnetbasis. Neodym / Stahl.

Neodymium Magnetic base. Neodymium/steel.

Base magnétique en néodyme/acier.

Base magnética em aço e neodímio.

Base magnética. Neodimio/Acero.

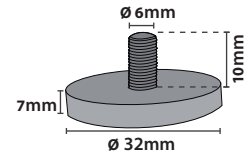
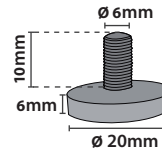

16.085	Base: Ø20x6mm Screw: Ø6 x10mm	x10		
16.086	Base: Ø32x7mm Screw: Ø6 x10mm	x10		

Magnetic Strip Roll

Magnetband 50m zur Befestigung von Pop Up.

Magnetic strip roll 50 meters.

Rouleau de bande magnétique de 50 mètres pour la fixation des images.

Rolo de íman de 50 metros para fixar impressões

Rollo de íman para fijación de gráficas.

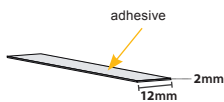

Magnetband mit Klebestreifen. Anisotrope.

Magnetic Strip with adhesive. Anisotropic.

Bande magnétique avec adhésif.

Fita magnética com adesivo. Anisotrópico.

Banda de ímán con adhesivo. Anisotrópico.

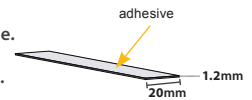

16.087	ml x1.2mm	
--------	-----------	--

Magnetband ohne Klebestreifen. Anisotrope.

Magnetic Strip without adhesive. Anisotropic.

Bande magnétique sans adhésif.

Fita magnética com adesivo. Anisotrópico.





Banda de ímán sin adhesivo. Anisotrópico.



16.088	ml x1.2mm	
--------	-----------	--

	QTY	N.W(kg)	G.W(kg)	C.B.M.	Size(mm)
Packing	10	9	10	0.02	290x200x290
10.360	50m x 12mm				

Magnetic Data Strip



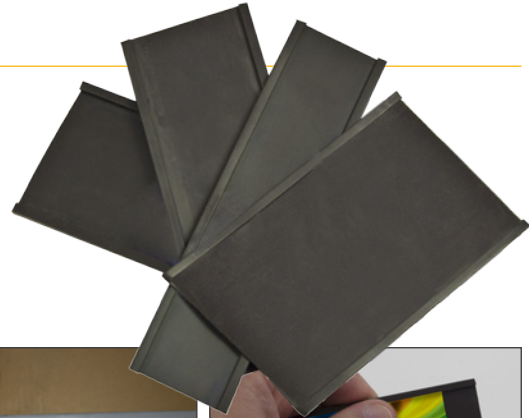

-  Flexible Magnetleiste für Etiketten.
-  Magnetic flexible data strip for labels.
-  Bande magnétique flexible, pour étiquettes.
-  Tira magnética para etiquetas.
-  Banda de imán flexible para etiquetas.

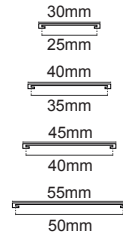

16.089	25mm	<input type="text"/>
16.090	35mm	<input type="text"/>
16.091	40mm	<input type="text"/>
16.092	50mm	<input type="text"/>





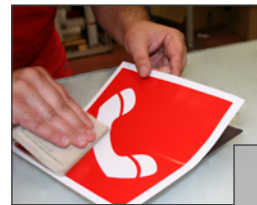
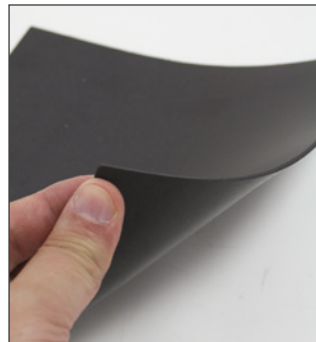

Magnetic Sheet Anisotropic

-  Magnetic-Folie 2 mm. Anisotrope.
-  Magnetic Sheet 2 mm. Anisotropic.
-  Feuille magnétique de 2mm.
-  Folha magnética com 2 mm. Anisotrópico.
-  Hoja magnética 2mm. Anisotrópico.

16.093	150x100x2mm	<input type="text"/>
16.094	950x400x2mm	<input type="text"/>





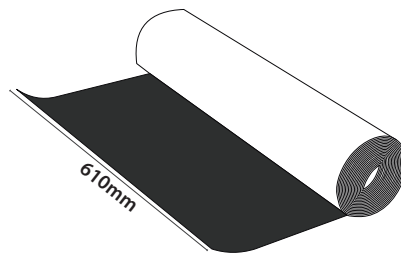

Magnetic Roll Anisotropic

-  Magnetrolle mit einer Seite aus weißem PVC.
-  Magnetic roll with white PVC on one side.
-  Rouleau magnétique en pvc blanc.
-  Rolo magnético com uma face em PVC branco.
-  Rollo magnético con una cara de PVC blanco.



16.095	610mm x 50m x 0.6mm	<input type="text"/>
--------	---------------------	----------------------

Anti-slip Pad

-  Anti-Rutsch-Pad mit einem Durchmesser von 10x3mm. Material: Silikon.
-  Anti-slip pad with diameter 10x3mm. Silicona.
-  Anti dérapant en silicone de 10x3mm.
-  Bolas anti deslizantes de silicone com 10x3 mm.
-  Lágrima antideslizante de 10x3mm. Silicona.

16.100	Ø 10mm	x120 	<input type="text"/>
--------	--------	--	----------------------







Magnetic Wrist Holder

-  Magnet-Armband.
-  Magnetic wrist holder.
-  Bracelet magnétique.
-  Pulseira magnética.
-  Pulsera magnética.



16.126

Magnetic Ruler

-  Magnet-Maßband cm/Zoll. 1000mm.
-  1000mm / 36" magnetic ruler.
-  Règle magnétique de 1000mm / 36".
-  Fita magnética de 1000mm / 36".
-  Regla magnética de 1000mm / 36".

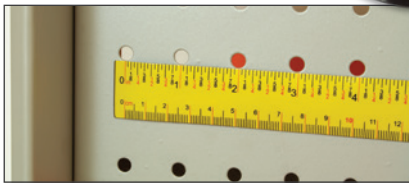





16.122

1000mm / 36"



Cleaning Swab

-  Reinigungsschwamm mit Kunststoffgriff für Druckköpfe, Tastaturen und Digital-Drucker.
-  Swab suitable for cleaning printheads, keyboards, digital printers, etc.
-  Pinceau pour le nettoyage des têtes d'impression, claviers, imprimantes digitales, etc.
-  Espátula para limpar os cabeçais de impressão, teclados, impressoras digitais, etc.
-  Paleta de plástico para la limpieza de cabezales, impresoras, teclados, etc.



16.008

x10 

Meter

-  Maßband 19x5000mm, mit Stopper und Magnetanschlag.
-  19x5000mm Meter. Brake and magnetic hook included.
-  Mètre de 19x5000mm. Inclus: frein et pointe aimantée.
-  Fita métrica com travão e ponta magnética.
-  Flexómetro de 19x5000mm. Incluye freno y punta imantada.







16.076

19x5000mm



Measuring Stick

-  Bandmaß mit 30 oder 50m.
-  30 or 50m Measuring stick.
-  Ruban métrique de 30 ao 50m.
-  Fita métrica com 30 au 50m.
-  Cinta métrica de 30 ó 50m.







16.070

30000mm

16.071

50000mm

Meter

-  Maßband von mehreren Maßnahmen mit Stopper.
-  Meter of several measures. Includes brake.
-  Mètre de plusieurs mesures. Inclus: un frein.
-  Fita métrica com travão.
-  Flexómetro de varias medidas. Incluye freno.

16.072

13x2000mm

x5 

16.073

16x3000mm

x5 

16.074

19x5000mm

x5 





16.075

25x10000mm

x5 



Linen Tester

-  Fadenzähler aus Kunststoff. 5X.
-  Linen tester, 5x.
-  Loupe en plastique. 5X.
-  Conta fios de plástico. 5X.
-  Cuentahilos de plástico. 5X.



16.077



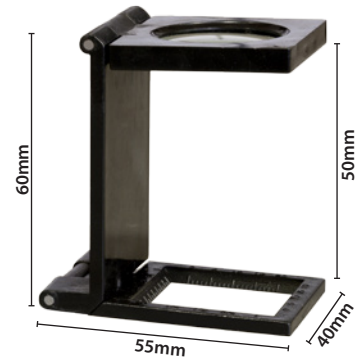

33.3mm



16.078

50mm

Linen Tester Luxe

-  Eleganter Fadenzähler mit Ledertasche. 25X.
-  Linen tester luxe, leather box. 25X.
-  Loupe de luxe avec une house en cuir. 25X.
-  Conta fios de luxo com bolsa de pele. 25X.
-  Cuentahilos de lujo con funda de piel. 25X.

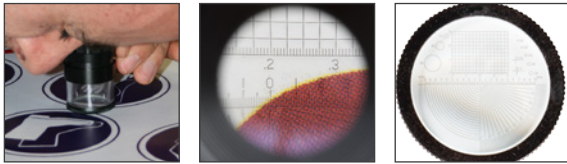





16.079

Ø 25 x 53mm





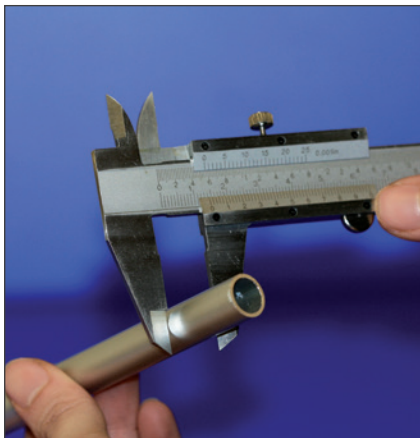

Hand Caliber

-  Messschieber 0-150mm.
-  0-150mm Hand caliper.
-  Calibre manuel de 0-150mm.
-  Calibrador manual de 0-150mm.
-  Calibre manual de 0-150mm.



16.058





Digital Caliber

-  Digitaler Messschieber 0-150mm.
-  0-150mm Electronic digital caliper.
-  Calibre digital de 0-150mm.
-  Calibrador digital 0-150mm.
-  Calibre digital de 0-150mm.



16.057

Special Accuracy Weighing Machine

-  Feinwaage von 0,01-300gr oder von 0,1-500gr.
-  Precision scale. Weight Capacity: 0,01-300gr and 0,1 gr-500gr.
-  Balance de précision. Capacité de mesure 0,01 à 300gr et 0,1 à 500gr.
-  Bilancia di precisione. Con una capacità di 0,01- 300gr e 0,1- 500gr.
-  Báscula de precisión. Con capacidad de 0,01-300gr y 0,1-500gr.



16.055



16.056



16.055 0,1 - 500gr

16.056 0,01 - 300gr

Metallic Cutter

-  Metall-Cuttermesser.
-  Metallic cutter. Steel.
-  Cutter métallique.
-  X-acto metálico.
-  Cutter metálico.



16.063

x5 

Professional Cutter

-  Profi Cuttermesser.
-  Professional cutter.
-  Cutter professionnel.
-  X-acto profesional.
-  Cutter profesional.



16.064

x5 

Snappy Safe Cutter

-  Folien-Cutter.
-  Snappy Safe Cutter.
-  Coupeur pour vinyle.
-  X-Acto para cortar vinil.
-  Cortador para vinilo.



16.007

x10 

Board Cutting Bar

-  Schneidlineal aus Metall mit Fingerschutz. 1000mm, 1500mm und 2500mm.
-  Metal ruler for cutting large pieces, with finger protection 1000mm, 1500mm y 2500mm.
-  Règle métallique pour couper de grandes pièces, avec protection pour les doigts.1000mm, 1500mm et 2500mm.
-  Régua metálica para corte de grandes peças, com protecção para os dedos, 1000mm, 1500mm e 2500mm.
-  Regla metálica para corte de grandes piezas, con protector para los dedos. 1000mm, 1500mm y 2500mm.





16.030 1000mm

16.031 1500mm

16.032 2500mm

Cutting Mat

 Schneidematte zur Schonung Ihrer Schreib-und Arbeitstische. Transparent, Erhältlich in 5 Größen.

 Cutting mat which ensures the protection of the workspace. Transparent Color. Available in 5 different sizes.

 Bâche facile à découper qui assure la protection du plan de travail. Couleur transparente. Disponible en 5 dimensions.

 Tapete de corte que proporciona uma melhor protecção da área de trabalho. Transparente. Disponível em 5 medidas.

 Tapiz de corte fácil de usar que asegura la protección del área de trabajo. Color transparente. Disponible en 5 medidas.

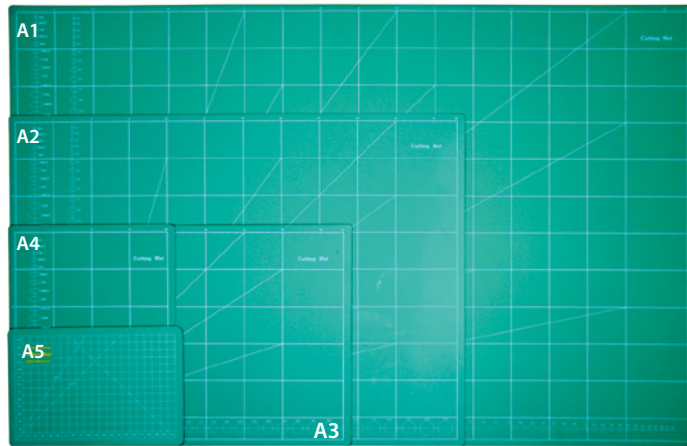

16.061	A5	<input type="checkbox"/>
16.062	A4	<input type="checkbox"/>
16.066	A3	<input type="checkbox"/>
16.067	A2	<input type="checkbox"/>
16.068	A1	<input type="checkbox"/>

Cable Ties

 Kabelbinder zum Binden oder Befestigen von Kabel, Planen und Schnüre.









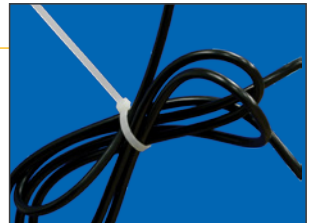



 Cable ties for holding graphics, cords, cables, etc.

 Brides pour tenir des visuels, cordes, câbles, etc.

 Abraçadeira para fixação de lonas, cabos, cordas entre outras.





 Bridas para la sujeción de lonas, cordeles, cables, etc.

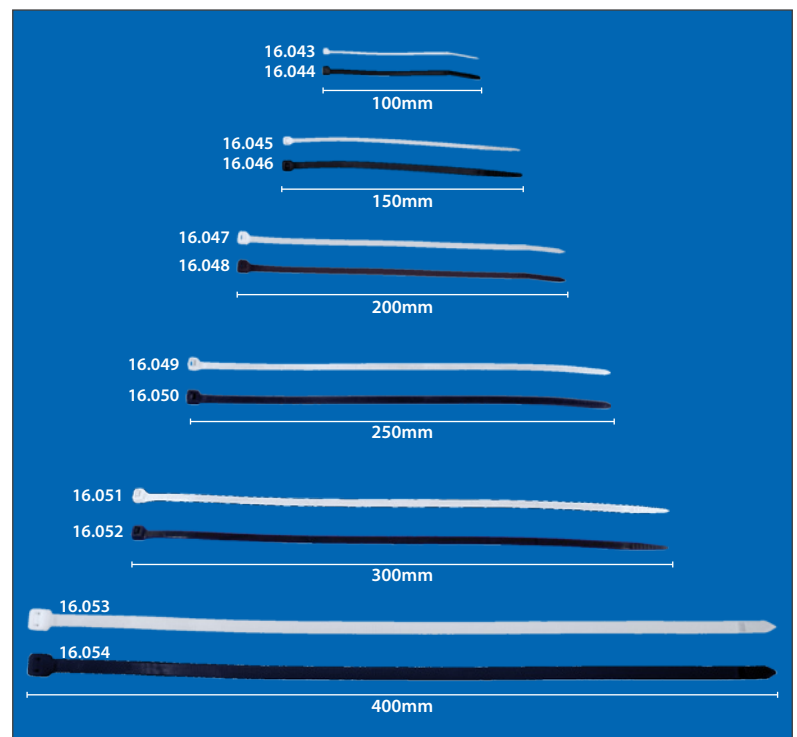

16.043	<input type="checkbox"/>	2.5x100mm	x100		<input type="checkbox"/>
16.044	<input checked="" type="checkbox"/>	2.5x100mm	x100		<input type="checkbox"/>
16.045	<input type="checkbox"/>	3.6x150mm	x100		<input type="checkbox"/>
16.046	<input checked="" type="checkbox"/>	3.6x150mm	x100		<input type="checkbox"/>
16.047	<input type="checkbox"/>	4.8x200mm	x100		<input type="checkbox"/>
16.048	<input checked="" type="checkbox"/>	4.8x200mm	x100		<input type="checkbox"/>
16.049	<input type="checkbox"/>	4.8x250mm	x100		<input type="checkbox"/>
16.050	<input checked="" type="checkbox"/>	4.8x250mm	x100		<input type="checkbox"/>
16.051	<input type="checkbox"/>	4.8x300mm	x100		<input type="checkbox"/>
16.052	<input checked="" type="checkbox"/>	4.8x300mm	x100		<input type="checkbox"/>
16.053	<input type="checkbox"/>	7.2x400mm	x100		<input type="checkbox"/>
16.054	<input checked="" type="checkbox"/>	7.2x400mm	x100		<input type="checkbox"/>





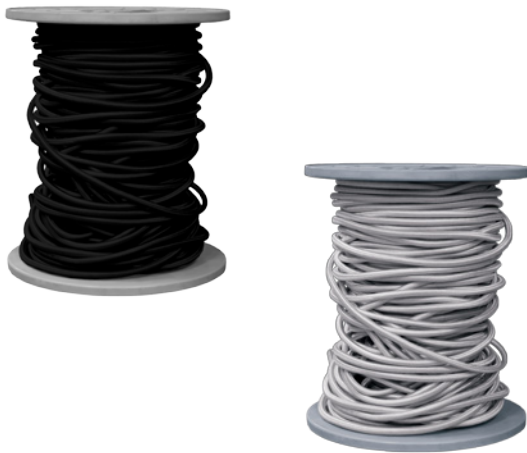

Elastic Cord

-  Gummischnüre in Schwarz oder Weiß. Mindest Bestelllänge: 100m.
-  White or black elastic cord. Minimum order: 100m.
-  Corde élastique blanche ou noire. Commande minimum de 100m.
-  Corda elástica branca ou preta. Venda mínima de 100m.
-  Cuerda elástica blanca o negra. Pedido mínimo de 100m.



16.039	<input type="checkbox"/>	Ø 6mm	
16.040	<input checked="" type="checkbox"/>	Ø 6mm	



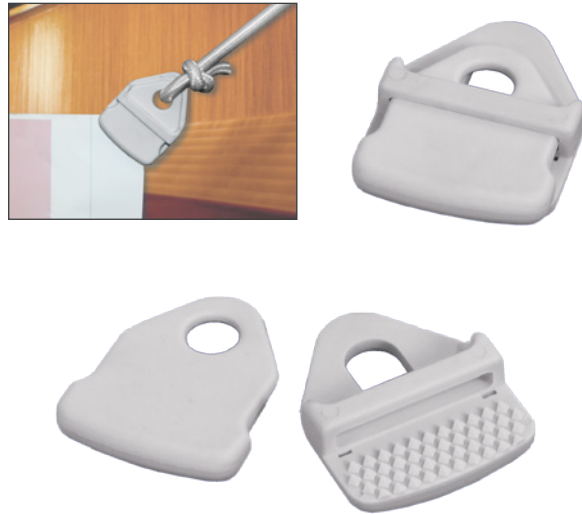

Corner Grips

-  Kunststoff-Planenklammer zum Spannen von Planen.
-  Plastic grips for holding panels.
-  Attaches en plastique pour fixation des bannières.
-  Clips de plástico para fixação de lonas.
-  Clips de plástico para fijación de lonas.



16.127	x20		
--------	-----	---	--



Fishing Nylon

-  Nylonfaden 0.5mm, Rolle 5m.
-  Blue Nylon Thread, 0.5mm diameter. Measure: 5m per roll.
-  Fil de nylon, de diamètre 0.5mm / Mesure: 5m par rouleau.
-  Fio de nylon com 0.5mm de diâmetro. Medida: 5m /rolo.
-  Hilo de Nylon, diámetro 0.5mm. Medida 5m/rollo.



16.037		Ø 0.4mm	
16.038		Ø 0.5mm	

Fishing Nylon

-  Nylonfaden mit 0.50mm oder 0.40mm Durchmesser. Rolle 500m Länge.
-  500m-Long fishing nylon. Available in 0.50mm and 0.40mm diameter.
-  Fil en nylon de 500m de longueur. Disponible en 0.50mm et 0.40mm de diamètre.
-  Fio de nylon com 500m de comprimento. Disponível com 0.50mm e 0.40mm de diâmetro.
-  Hilo de nylon de 500m de longitud. Disponible en 0.50mm y 0.40mm de diámetro.



12.373	5m	x50		
--------	----	-----	---	--

Hot Air Gun

 Heißluftpistole zur Verarbeitung von Folien.

 Hot air gun for applying vinyl.

 Pistolet à air chaud pour la mise en place de vinyles.

 Pistola de ar quente.

 Pistola de aire caliente para aplicación de vinilos.



Voltage & Frequency:	230V ~ 50Hz
Rate power I/II:	1000/2000W
Temperature I/II:	350/550° C
Air flow I/II:	300/500 l/min.
VDE plug.	2m cable.



16.128



Voltage & Frequency:	230V ~ 50Hz
Rate power:	2000W (Max)
Temperature I/II/III:	80/80-600/80-600°C
Air flow I/II/III:	350/350/500 l/min.
VDE plug.	2m cable.
Adjust temperature.	



16.129



Voltage & Frequency:	230V ~ 50Hz
Rate power I/II:	2000W (Max)
Temperature I/II:	50/70-600/70-600°C
Air flow I/II:	300/300/500 l/min.
Display:	LCD
VDE plug, 2m cable.	



16.130



Button Making Machine

 Buttonmaschine manuell, inklusive Werkzeug für 25mm oder 37mm oder 58mm.

 Button making machine. Includes moulds. Available in 3 different diameters 25mm, 37mm ó 58mm.

 Machine pour réaliser des plaques avec une matrice incluse. Disponible avec matrice de dimension de 25mm, 37mm, 58mm.

 Máquina manual para realizar crachás com matriz incluída. Os tamanhos das matrizes disponíveis são de 25 mm, 37 mm ou 58 mm.

 Máquina manual para realizar chapas con matriz incluída. Disponible con matrices de tamaño 25mm, 37mm ó 58mm.



16.131 Ø 25mm

16.132 Ø 37mm

16.133 Ø 58mm

Metal Pin Badge

 Buttonzubehör bestehend aus Metalloberteil, Metallunterteil mit Sicherheitsnadel und Schutzfolie. Verfügbar in 3 Durchmesserem.

 Metal plates. Includes frontal, rear with safety pin and protective film. Available in 3 diameters.

 Plaques en métal avec d'inclus une épingle à nourrice sur la partie arrière ainsi qu'un film protecteur. Disponible en 3 dimensions.

 Crachá metálico que inclui uma parte frontal, uma parte traseira com fecho de segurança e uma película protectora. Diposíveis em 3 diâmetroso.

 Chapas de metal. Incluye parte frontal, trasera con imperdible y film protector. Disponible en 3 diametros.



16.134 Ø 25mm x100 

16.135 Ø 37mm x100 

16.136 Ø 58mm x100 

Plastic Pin Badge

 Buttonzubehör bestehend aus Ober- und Unterteil aus Kunststoff, Sicherheitsnadel und Schutzfolie. Verfügbar in 3 Durchmesserem.

 Plastic sheets. Includes frontal, rear with safety pin and protective film. Available in 3 diameters.

 Plaques en plastique avec d'inclus une épingle à nourrice sur la partie arrière ainsi qu'un film protecteur. Disponible en 3 dimensions.

 Crachá plástico que inclui uma parte frontal, uma parte traseira com fecho de segurança e uma película protectora. Diposíveis em 3 diâmetros.

 Chapas de plástico. Incluye parte frontal, trasera con imperdible y film protector. Disponible en 3 diametros.







16.137 Ø 25mm x100 

16.138 Ø 37mm x100 

16.139 Ø 58mm x100 





Table Eyelet Plier

-  Ösenpresse - Nietzange. Werkzeug für 10mm inklusive.
-  Table eyelet plier. 10mm Header included.
-  Pince pour oeuillets qui se pose sur une table.
-  Máquina de mesa para colocar ilhoses.
-  Olladora de mesa. Cabezal de 10mm incluido.







16.019

Eyelets

-  Ösen für Ösenpresse. Vernickelt antikfarben oder silberfarben mit 6mm, 8mm, 10mm und 12mm.
-  Eyelets for table eyelet pliers. Available in gold and silver. Diameters: 6mm, 8mm, 10mm and 12mm.
-  Oeuillets pour les pinces de table. 6mm, 8mm, 10mm y 12mm.
-  Ilhoses para máquina de mesa de colocar ilhoses. Disponíveis em dourado e prateado, com 6mm, 8mm, 10mm e 12mm.
-  Ollados para olladora de mesa. Disponibles en dorado y plateado en 6mm, 8mm, 10mm y 12mm.





Adapters

-  Werkzeug für Ösenpresse. Verfügbar in 6mm, 8mm, 10mm und 12mm.
-  Adapters for table eyelet plier. Available in 6mm, 8mm, 10mm and 12mm.
-  Adaptateurs de pince pour oeuillets. 6mm, 8mm, 10mm y 12mm.
-  Adaptadores para máquina de mesa. Disponíveis em 6mm, 8mm, 10mm e 12mm.
-  Adaptadores para olladora de mesa. Disponibles en 6mm, 8mm, 10mm y 12mm.

16.121		Ø 6mm	<input type="text"/>
16.020		Ø 8mm	<input type="text"/>
16.120		Ø 10mm	<input type="text"/>
16.021		Ø 12mm	<input type="text"/>

Eyelet Plier

-  Ösenpresse - Nietzange. Werkzeug für 10mm inklusive.
-  Table eyelet plier. 10mm Header included.
-  Pince pour oeuillets qui se pose sur une table.
-  Máquina de mesa para colocar ilhoses.
-  Olladora de mesa. Cabezal de 10mm incluido.



16.060

16.026	6mm	x1000 	<input type="text"/>		
16.022	6mm	x1000 	<input type="text"/>		
16.027	8mm	x1000 	<input type="text"/>		
16.023	8mm	x1000 	<input type="text"/>		
16.028	10mm	x1000 	<input type="text"/>		
16.024	10mm	x1000 	<input type="text"/>		
16.029	12mm	x1000 	<input type="text"/>		
16.025	12mm	x1000 	<input type="text"/>		

